

ASSESSMENT OF REMOTE-HANDLED TRANSURANIC WASTE IN SHIELDED CONTAINERS^a

C. R. Hoffman
Idaho National Laboratory
P.O. Box 1625, Idaho Falls, ID 83415

R. Bhatt
Idaho Completion Project
P.O. Box 1625, Idaho Falls, ID 83415

ABSTRACT

The Idaho National Laboratory (INL) and the Idaho Completion Project (ICP) are working to develop a disposition process whereby approximately 1,400 containers of “suspect” remote-handled (RH) transuranic (TRU) waste. These containers were shipped by the Rocky Flats Environmental Technology Site (RFETS) to the Radioactive Waste Management Complex at the INL from 1970 through 1988. These containers have lead liners, lead tape wrapped around liners, or components with internal lead shielding, all of which were designed to protect workers from exposure to radiation. The lead-shielded waste is labeled as “suspect” RH TRU waste, because the lead shielding does not allow an unshielded external dose-rate measurement of the container contents. “Suspect” RH TRU waste poses a unique challenge for characterization and transportation.

A TRU waste container with an external contact-dose rate of 200 mrem/hour, or greater, is defined as RH TRU waste in the “Land Withdrawal Act.”[1] In accordance with the Land Withdrawal Act definition, the “suspect” RH TRU waste could be characterized and certified as contact-handled (CH) TRU waste. However, an intrusive characterization could produce RH TRU waste, and Waste Isolation Pilot Plant (WIPP) currently does not have authorization to dispose of RH TRU waste. Moreover, the current safety analysis report for the Transuranic Package Transporter Model II (TRUPACT-II) prohibits transportation of any container with an unshielded contact-dose rate higher than 200 mrem/hour. Therefore, even if the lead-lined containers were characterized as CH TRU waste, transportation could be performed using only the casks authorized for RH TRU waste shipments.

Casks currently authorized to transport RH TRU containers are the 72B Cask or the Chem-Nuclear System (CNS) 10-160B Cask. However, the CNS 10-160B Cask cannot be used for all lead-lined containers of waste, because the Am-241 content of this waste would exceed the certificate-of-compliance limit of the cask.[2] In the case of the 72B Cask, the canister is the disposal container. Because of the shielding provided by the 0.635-cm canister wall thickness, the surface-dose measurement of the canister would be less than 200 mrem/hour for the “suspect” RH TRU waste, and the canister could be disposed of as CH TRU waste rather than RH TRU waste.[3] Handling of the 72B Cask canister for CH TRU waste transport and disposal would require a procedural change at WIPP.

The INL and the ICP are currently evaluating methods for determining whether “suspect” RH TRU waste is RH TRU or CH TRU waste—without opening the container. This would allow

determination of the characterization path and also would limit potential radiation exposure for waste operators. Once the population of waste drums is segregated into CH and RH waste, a path forward for the RH portion of the lead-lined containers would need to be discussed with WIPP and the regulatory agencies.

INTRODUCTION

Approximately 1,400 lead-lined containers (303 m³) of “suspect” remote-handled (RH) transuranic (TRU) waste are currently stored at the Radioactive Waste Management Complex (RWMC) at the Idaho National Laboratory (INL). These waste containers are identified as “suspect” RH TRU waste, because of the lead shielding used to reduce the possible external contact-dose rate of the waste containers. When the waste was generated, no single set of requirements regarding the surface dose rate was maintained. Today, the documentation of the unshielded contact-dose rate of the waste in these containers does not exist. Therefore, whether the waste is contact-handled (CH) TRU or RH TRU cannot be determined without opening the waste containers, and opening the waste containers would increase the exposure to personnel. The INL and the Idaho Completion Project (ICP) are currently developing a characterization and transportation process for sending this waste stream to the Waste Isolation Pilot Plant (WIPP) for disposal

It should be recognized that the definitions of RH TRU and the CH TRU definitions overlap. A TRU waste container with an external contact-dose rate of 200 mrem/hour, or greater, is defined as RH TRU waste in the “Land Withdrawal Act.”[1] While the CH TRU definition as defined by the CH TRU Waste Acceptance Criteria is TRU waste with a surface radiation dose equivalent rate not greater than 200 mrem/hour.[4] In addition to the RH TRU and the CH TRU definition the Transuranic Package Transporter Model II (TRUPACT-II) Safety Analysis Report (SAR) limits the unshielded dose rate of the payload container shipped in TRUPACT-II’s cask to less than or equal to 200 mrem/hour.[5]

DESCRIPTION OF “SUSPECT” REMOTE-HANDLED TRANSURANIC WASTE

The “suspect” RH TRU waste was originally generated during purification of plutonium materials that involved removal of Am-241 during fabrication, assembly, and processing of nuclear weapons components at the Rocky Flats Environmental Technology Site (RFETS) from 1968 through 1988. The RFETS shipped these containers of “suspect” RH TRU waste to the RWMC from 1970 through 1988. (It should be noted that before 1970, no differentiation was made between CH TRU and RH TRU waste.) Most of the “suspect” RH TRU waste is under earthen cover in the Transuranic Storage Area-Retrieval Enclosure at the RWMC. Additional containers may have been buried before 1970 and are currently being retrieved as newly generated waste. The estimate of 303 m³ of “suspect” RH TRU waste is based on an investigation of the waste inventory received from 1971 through 1988 and extrapolation for the inventory received from 1970 through 1971.[6]

“Suspect” RH TRU waste varies from solidified sludge to debris. The presence of Am-241 in a relatively large quantity in a waste container (i.e., more than 3–5 g) would likely cause the waste to be classified as RH due to the 59-keV gamma-ray emission during the decay process. The shielding criteria employed by RFETS changed over the years. In the late 1970s and early 1980s, the general operating philosophy was to use lead liners when drums were suspected to contain

more than 5 g of Am-241. However, procedures established in 1985, and later, required a 200-mrem/hour limit of the container-surface dose, for personnel protection.[7]

The three lead-shielding configurations used in the “suspect” RH TRU waste containers were:

1. Lead liner or sheeting (see Figure 1) placed between the rigid polyethylene liner and the drum
2. Rigid liners in sludge drums wrapped within 0.15-cm lead tape (see Figure 2)
3. Components with internal lead shielding.

Lead disks were also placed at the top and bottom of the drum with the first two configurations. Lead liners or lead tape wrapped around a liner were used when (1) the waste was generated from the americium lines or (2) U-233 was known or expected to be in the waste.

Because documentation for the unshielded-contact dose rate of these containers does not exist, they are “suspect” RH TRU and pose unique transportation problems.

DESCRIPTION OF CHARACTERIZATION AND TRANSPORTATION PROBLEM

In accordance with current WIPP requirements, the containers of “suspect” RH TRU waste described above qualify as CH TRU waste; however, WIPP waste-characterization requirements call for visual inspection of a select number of waste containers. If a “suspect” RH TRU container was visually examined repackaging would occur. If the shielding was removed, the waste might meet specifications for RH TRU waste, and would, therefore, need to be certified as RH TRU waste—unless it were repackaged in another lead-lined container. Once characterized, the lead-lined containers that potentially have an unshielded-dose rate of 200 mrem, or greater, pose a transportation challenge. Because of this limitation, the only option for transportation is to use casks approved for RH TRU waste.

BACKGROUND INFORMATION ON TRANSPORTATION CASKS

Although four casks are approved for shipment of TRU waste to WIPP, only the following three casks are being considered for the shipment of “suspect” RH TRU waste from the RWMC: (1) the TRUPACT-II, (2) the 72B Cask, and (3) the Chem-Nuclear System (CNS) 10-160B Cask.

The SAR for the TRUPACT-II requires an unshielded-dose rate of less than or equal to 200 mrem/hour.[5] The unshielded contact-dose rate for the lead-lined waste container is unknown; therefore, the container is designated as “suspect” RH TRU waste. A special

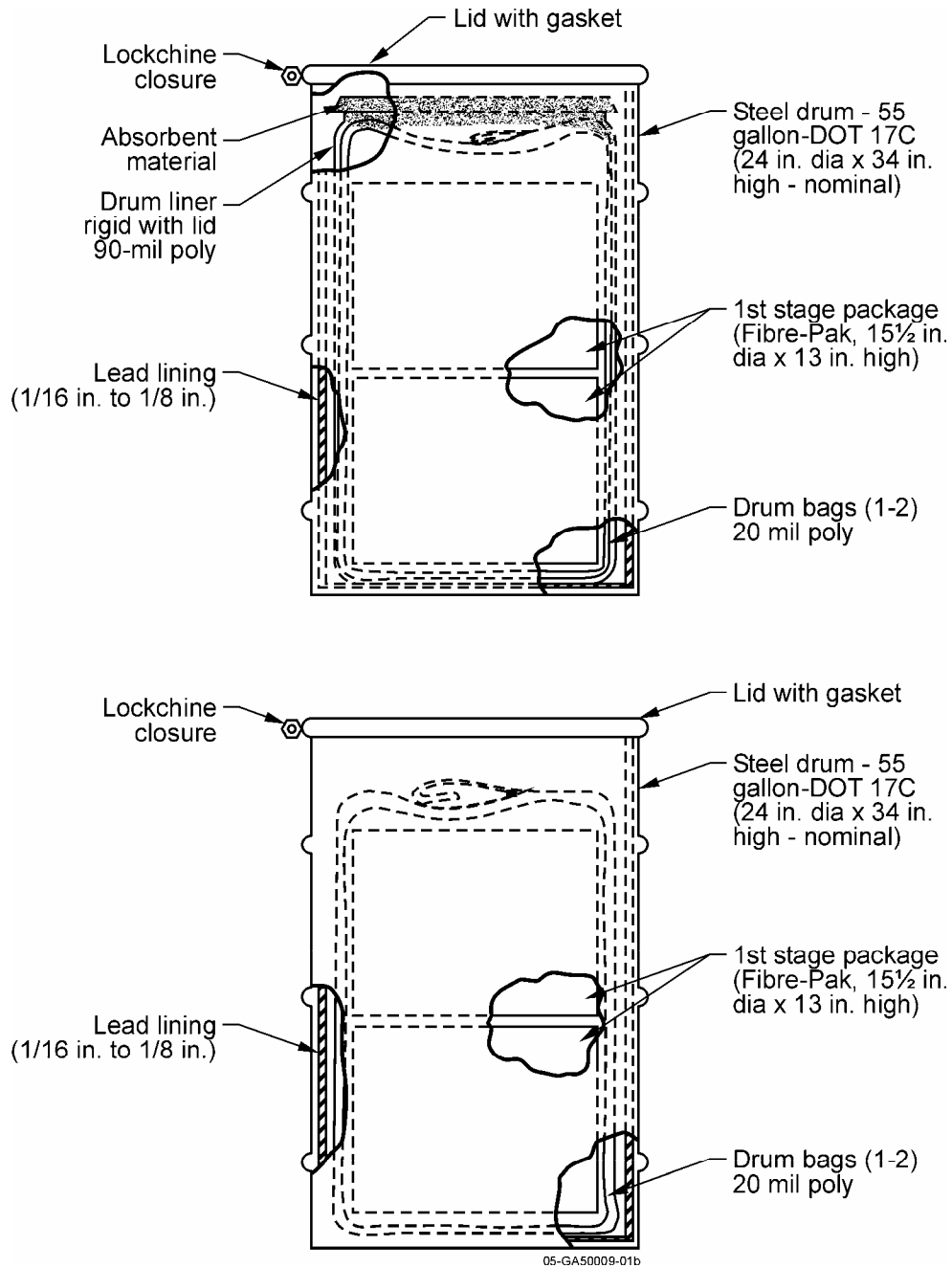

Fig. 1. Configuration of “suspect” remote-handled transuranic lead-lined waste in container.

analysis would be required, for submittal to the U.S. Nuclear Regulatory Commission for approval, to justify the shipment of lead-lined containers. This is to ensure that the unshielded-dose rate is 200 mrem/hour or below, or that if the container has an

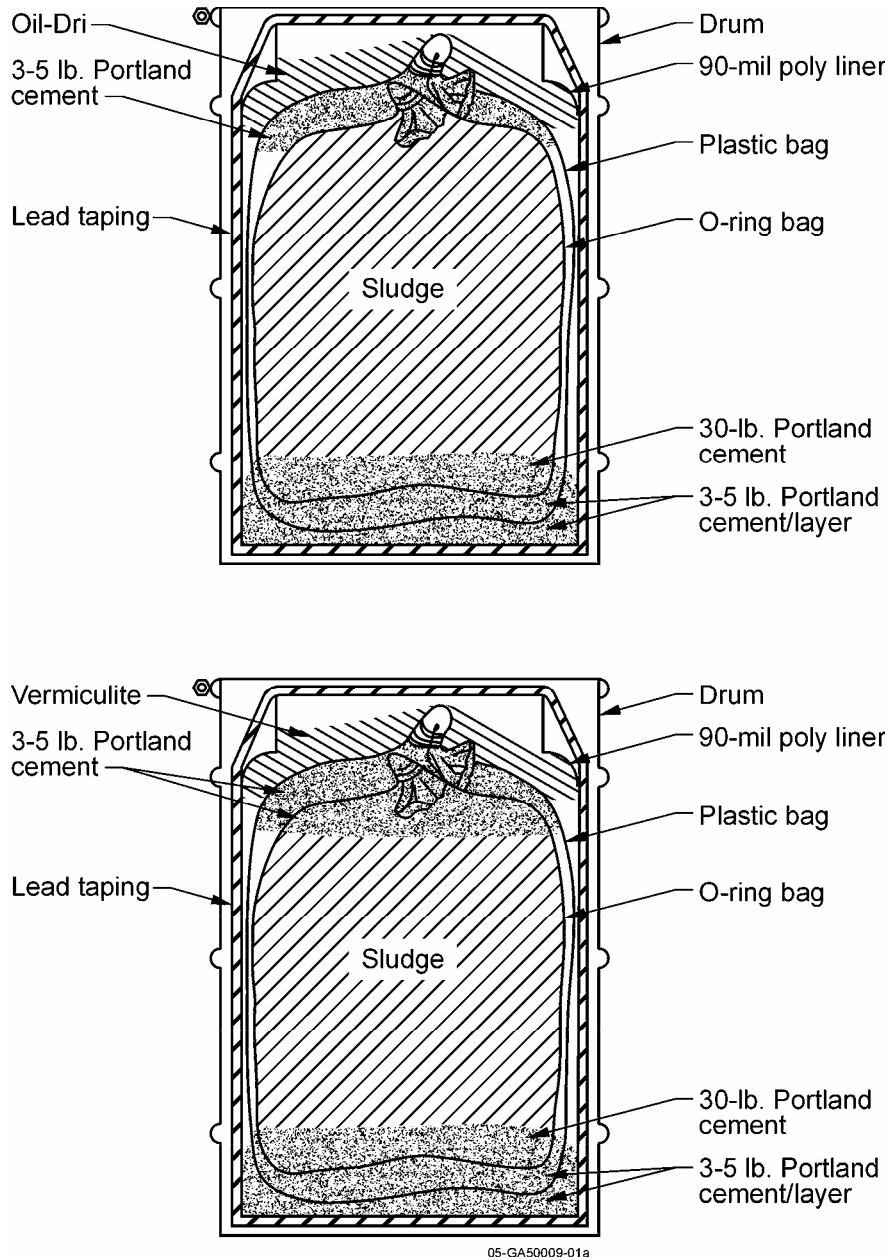

Fig. 2. Rigid liners in sludge drums wrapped within 0.318- or 0.158-cm (1/8- or 1/16-in.) lead tape.

unshielded dose rate of 200 mrem/hour or above, the integral shielding will not shift in transit.

The 72B Cask and the CNS 10-160B Cask have adequate shielding, and the waste in lead-lined containers can be shipped in these casks. However, using either one of these casks would require a modification either to a WIPP procedure and/or to the SAR applicable to casks for shipping a container of "suspect" RH TRU waste.

It should be noted that the canister for the 72B Cask serves as the disposal container for RH TRU waste. If “suspect” RH TRU waste is loaded in the 72B Cask canister, the surface dose of the canister would be lower than 200 mrem/hour, even if the internal shielding within the waste container were no longer effective. Based on the surface-dose rate, the canister would need to be disposed of as CH TRU waste. However, this would require a change of procedures at WIPP, because the 72B Cask is approved only for RH TRU operations, and RH procedures would no longer be applicable. The CNS 10-160B Cask cannot be used when waste containers have more than 20 Ci of Am-241, because of the SAR limits.[2] For “suspect” RH TRU waste to be sent in the CNS 10-160B Cask, a change in the SAR would be required, because of the Am-241 content of the waste.

QUESTIONS TO BE ADDRESSED

Questions that need to be answered before this waste can be sent to WIPP for disposal include the following:

1. Can waste that is characterized and certified as CH TRU waste in a shielded container be accepted for disposal at WIPP?
2. Can the TRUPACT-II SAR be modified to include a statement to allow shipment of waste in a shielded container with additional analysis that proves that integral lead shielding will not shift during transit?
3. Can lead-lined containers of waste be transported in a 72B Cask and the canister be disposed of as CH TRU waste? Will the panel-ceiling height be sufficient to allow vertical disposal, or will horizontal disposal be necessary?
4. Can the SAR for CNS-10-160B Cask be revised to increase the 20-Ci limit for Am-241? Can the WIPP procedures be revised to handle a CNS-10-160B Cask for CH TRU operations?

The purpose for asking these questions is twofold:

1. The “suspect” RH TRU waste from the RWMC needs to be sent to a permanent disposal facility (i.e., WIPP).
2. Lead shielding used in the containers protects workers, and removing that shielding to determine whether the waste is CH TRU or RH TRU is counterproductive. Therefore, the ICP proposes that lead-lined TRU waste be characterized and disposed of as CH TRU waste.

SOLUTIONS PROPOSED BY THE IDAHO COMPLETION PROJECT

The INL and the ICP are developing a path forward—for characterization and disposition of the waste stored in lead-lined containers—that would be beneficial to the INL and the U.S. Department of Energy community. The ICP proposes that the entire waste stream be characterized as CH TRU waste and be treated as such, based on the container external-dose-rate measurement. To manage transportation, ICP proposes developing a method to assess whether waste in a TRU waste container is CH TRU or RH TRU waste, based on the following:

- Computer modeling and differential attenuation
- Surrogate measurements
- Total measurement uncertainty.

Measurement of containers using gamma spectroscopy and computer modeling will be one aspect of the method used to determine thickness of the shielding, the quantity of Am-241, and the unshielded contact-dose rate of a drum. Based on the unshielded contact-dose rate determined, an appropriate cask can be used for transportation using the following guidelines:

1. If the unshielded contact-dose rate is expected to be 200 mrem/hour or below, either TRUPACT II or RH 72B casks could be used for transportation.
2. If the unshielded contact-dose rate of a container could potentially exceed 200 mrem/hour, the 72B Cask could be used for transportation, because the 0.635-cm wall thickness is sufficient to reduce the contact-dose rate for most of the "suspect" RH TRU waste at the RWMC.

Other aspects that would need to be determined are (1) an appropriate nondestructive examination (e.g., real-time radiography) system to "see" through the lead shielding and (2) a nondestructive assay system to make the determination of activity and unshielded-dose rate. A simple health physics instrument or a passive gamma-spectrometry system could be used to obtain the input information for the model. Simple modeling (e.g., MicroShield) may be employed for the lead liner and tape configurations, as a starting point. Waste drums with vials, or containers wrapped with lead tape inside of a waste container may require a more detailed analysis (e.g., Monte Carlo Neutron Photon Code). A comparison of the detailed analysis to laboratory measurements would need to be performed.

The nondestructive examination of the waste containers (e.g., real-time radiography) would provide information on the type of lead shielding used to establish the unshielded contact-dose rate. Once modeling calculations are performed for attenuation from lead shielding, surrogate measurements would be used for confirmation. With the modeling and surrogate measurements, a total measurement uncertainty would need to be performed to assess accuracy of the method. Once this has been concluded, the U.S. Department of Energy Carlsbad Field Office would need to approve the method.

This method would eliminate the need to open the container and remove the shielding, and would eliminate potential exposure for the waste operators. Based on these assessments, transportation casks could be assigned to the containers after those containers were characterized as CH TRU waste. The assessment would also potentially increase the number of drums from RWMC that would meet the TRUPACT-II SAR requirement of an external unshielded-dose rate of less than or equal to 200 mrem/hour.

CARLSBAD FIELD OFFICE ACTIONS

What can CBFO do with respect to the shipment and disposal of "suspect" RH TRU waste?

A policy decision could be made, and regulatory approval obtained, to allow waste in lead-lined drums to be characterized and managed as CH TRU waste. After the waste was characterized, transportation could be achieved either by modifying the TRUPACT-II SAR to allow shipment of lead-lined containers or by using the 72B Cask or the CNS-10-160B. However, transportation using either the 72B or the CNS-10-160B Cask would require a modification to the WIPP procedure.

CONCLUSION

A policy decision needs to be made at WIPP and proposed to regulators for disposition of lead-lined waste, because it does not make sense to remove lead simply to identify whether the waste would be RH TRU or CH TRU. The purpose of shielding is to reduce exposure to waste operators. We propose that the waste should be disposed of as is (i.e., characterized as CH TRU waste), and either the TRUPACT II SAR should be revised for shipment or the WIPP procedure should be modified to allow 72B or CNS-10-160B Casks to be used for disposition as CH TRU waste.

REFERENCES

1. Public Law 102-579, "The Waste Isolation Pilot Plant Land Withdrawal Act," U.S. Government (1992).
2. *Safety Analysis Report for Chem-Nuclear Systems Model CNS 10-160B Type B Radwaste Shipping Cask*, NRC Docket 71-9204, Washington, D.C., Office of Regulatory Procedures, U.S. Nuclear Regulatory Commission.
3. *72B Certificate of Compliance*, NRC Docket 71-9212, Washington, D.C., Office of Regulatory Procedures, U.S. Nuclear Regulatory Commission (2002).
4. U.S. Department of Energy, 2004, *Contact-Handled Waste Acceptance Criteria for the Waste Isolation Pilot Plant*, DOE/WIPP-02-3122, Revision 2.0, November 15, 2004, Carlsbad, NM.
5. *TRUPACT-II Safety Analysis Report*, NRC Docket 71-9218, Washington, D.C., Office of Regulatory Procedures, U.S. Nuclear Regulatory Commission (2004).
6. EDF-4379, "Volume of Remote Handled Transuranic Waste," Rev. 0, Idaho Completion Project (2004).
7. Abbott, C., *Historical Background Report for Lead-Lined Rocky Flats Plant Waste Shipped to the INEEL from 1970 to 1988*, ICP/EXT-04-00632, Idaho Completion Project (2004).

FOOTNOTES

- a. Work supported by the U.S. Department of Energy, Office of Assistant Secretary for Environmental Management, under DOE Idaho Operations Office Contract DE-AC07-99ID13727.