

## **Development of a New 48 Inch UF<sub>6</sub> Cylinder Overpack – 17476**

Tanya Sloma \*, Philip Sewell \*, Andy Langston \*, Arefaine Wegahta \*  
\* DAHER-TLI

### **ABSTRACT**

The Kevil Kougar overpack is new generation USA DOT Specification 7A packaging designed to transport ANSI N14.1 [1] and ISO-7195 [2] compliant 48-inch UF<sub>6</sub> cylinders.

In December 2016, the USA DOT [3] issued USA/0815/H(U)-96 for the transport of 48X and 48Y cylinders and USA/0819/H(M)-96 for the transport of 48G, 48H, 48HX, 48O, 48OM, 48OM(Allied) and 48T cylinders. The H(U) certificate is for transport of thick-walled cylinders and the H(M) certificate is for transport of thin-walled cylinders. The Kevil Kougar design provides thermal and impact protection for the cylinder under conditions required for a Type A package capable of transporting UF<sub>6</sub> via road, rail, and ocean.

The packaging design is a smooth octagonal shape designed to carry one 48-inch UF<sub>6</sub> cylinder. It consists of an upper subassembly and lower subassembly, which are fastened together with ten toggle bolts, five per side. Each subassembly consists of an outer and inner steel shell secured to a frame assembly, with wood and polyurethane foam filling the space between. The protruding components are only for ease of operation and consist of four lifting lugs and fork pockets on the upper body, and the base and fork pockets on the lower body. The design incorporates interior rubber pads for cylinder cushioning, support and alignment, steel stabilizing beams fore and aft to prevent cylinder movement, closure mechanisms, a tamper indicating device and tie-down features.

The Kevil Kougar is currently designed to transport contents of depleted uranium and natural uranium. Future activities include licensing the package as Type AF to facilitate transport of historic USA Department of Energy fissile material packages.

### **INTRODUCTION**

The Kevil Kougar overpack, shown in Figure 1, is a licensed Type H(U) and H(M) package capable of transporting ANSI N14.1 and ISO-7195 compliant 48-inch cylinders. ANSI N14.1 [1] and ISO-7195 [2] cylinders are typically used for the storage and transport of larger quantities of Uranium Hexafluoride (UF<sub>6</sub>). 48-inch UF<sub>6</sub> cylinders like 48X, 48Y and 48G are common examples of ANSI N14.1 and ISO-7195 compliant cylinders that can be stored and shipped using the Kevil Kougar overpack.

US and international transport regulations [3] [4] allow for shipments of full “thick-walled” 48-inch UF<sub>6</sub> cylinders (most commonly 48X and 48Y). Specifically, thick-walled cylinders have been shown to meet the requirements of 49CFR173.420,

which requires cylinders containing greater than 0.1 kg of UF<sub>6</sub> (fissile, fissile excepted or non-fissile) must, 1) have been designed to withstand a hydraulic test of at least 1.4 MPa without leakage, 2) withstand the test specified in 49CFR173.465(c) without loss or dispersal of UF<sub>6</sub> and, 3) withstand the test specified in 10CFR71.73(c)(4).

Thin-walled cylinders have not been tested to withstand the tests required in 173.420; therefore, additional protection must be provided in the form of a protective shipping package. Thin-walled cylinders were fabricated of 5/16" steel and have the designation, 48G, 48H, 48HX, 48O, 48OM, 48OM(Allied) and 48T. The thin-walled cylinders may in fact follow ANSI N14.1 and may be within certification but because they have not been tested a protective package is required for shipment. The DOT recognizes three protective shipping packages for thin-walled cylinders; the CI-48, P-48 and Kevil Kougar each can provide the necessary structural and thermal protection for a thin-walled cylinder. However, all CI-48s and P-48s are owned by the DOE and therefore are not available for commercial use.

The Kevil Kougar packaging is designed to meet this need and provide a protective overpack that can be used to allow shipments of any ANSI N14.1 and ISO-7195 compliant 48-inch UF<sub>6</sub> cylinders via road, rail, or ocean while meeting all relevant US or international regulatory requirements. The current contents licensed for the Kevil Kougar package include natural and depleted uranium.



Fig. 1. The Kevil Kougar Package.

## KEVIL KOUGAR DESIGN

The packaging design is a smooth octagonal shape designed to carry one 48-inch UF<sub>6</sub> cylinder. Materials of construction of the overpack include steel, wood and foam. The Kevil Kougar overpack provides thermal and impact protection for the 48-inch cylinder, such that containment of the contents is maintained.

Thermal protection for the 48-inch cylinder and UF<sub>6</sub> contents is provided by low-density polyurethane foam and wood blocks. The components are layered in the upper and lower subassemblies of the Kevil Kougar packaging. Figure 2 depicts the upper and lower subassemblies of the overpack. The outer shell of the overpack shields the foam and wood from direct exposure to flame in the event of a fire accident, see Figure 3. Vents in the outer shell prevent internal pressure buildup in the overpack due to off-gassing of the foam that could occur. However, these vents do not relieve pressure in the 48-inch cylinder.

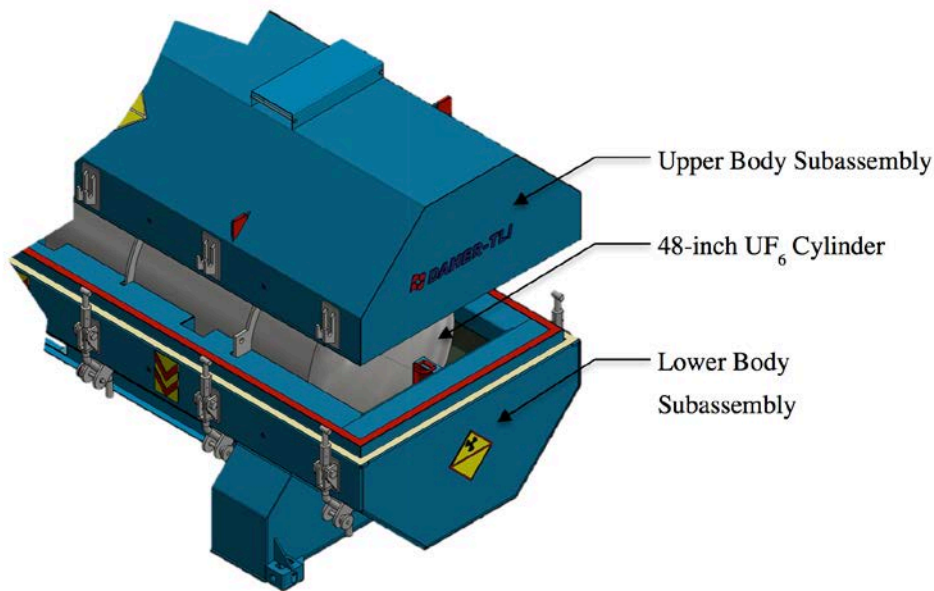

Fig. 2. Kevil Kougar Overpack Upper and Lower Subassemblies and a Sample 48-inch UF<sub>6</sub> Cylinder.

Impact protection is provided by the shock limiting properties of the same components that provide thermal protection. The foam and wood blocks act together to absorb impact energy and provide efficient thermal insulation. Figure 3 is a cutaway of the end view of the Kevil Kougar design showing a sample arrangement of the thermal insulation and impact limiting materials.

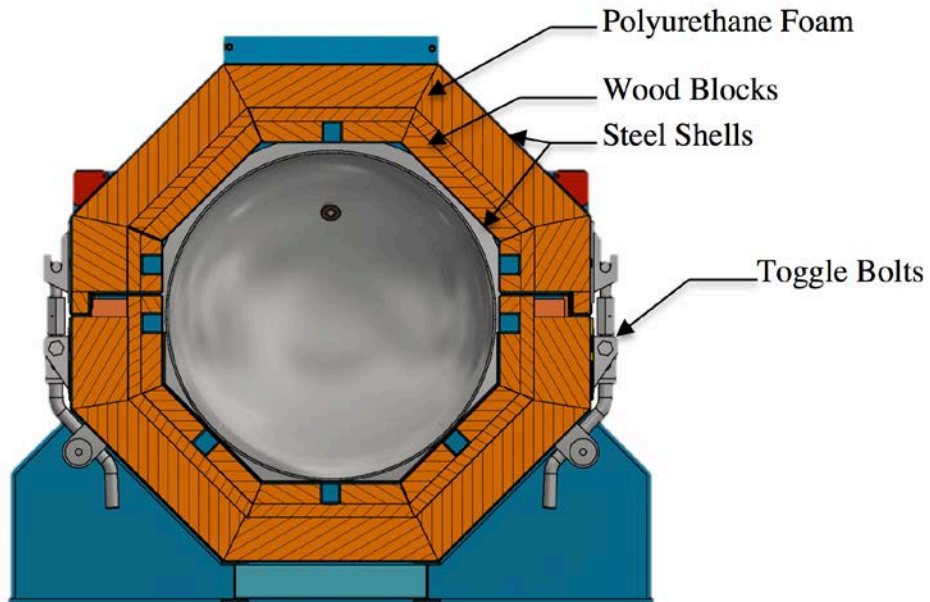

Fig. 3. Kevlar Kougar Thermal insulation and Impact Limiting Components Sample Arrangement.

### KEVLAR KOUGAR THERMAL AND STRUCTURAL TESTS

The protection capability of the overpack is tested according to the requirements for the  $UF_6$  packaging in 49CFR173 [3] and SSR-6 [4].

#### Thermal test

The thermal test is conducted using the ANSYS finite element analysis software [5] to study the internal and external temperatures of the package during Normal Conditions of Transport (NCT) and Hypothetical Accident Conditions (HAC). The thermal analysis results are documented in Figure 4 and Figure 5 for NCT and HAC, respectively.

### Package Temperature

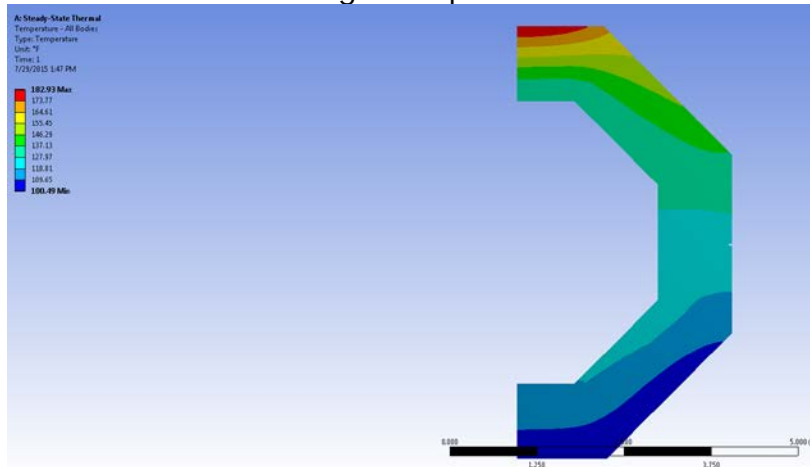

### Internal Air Temperature

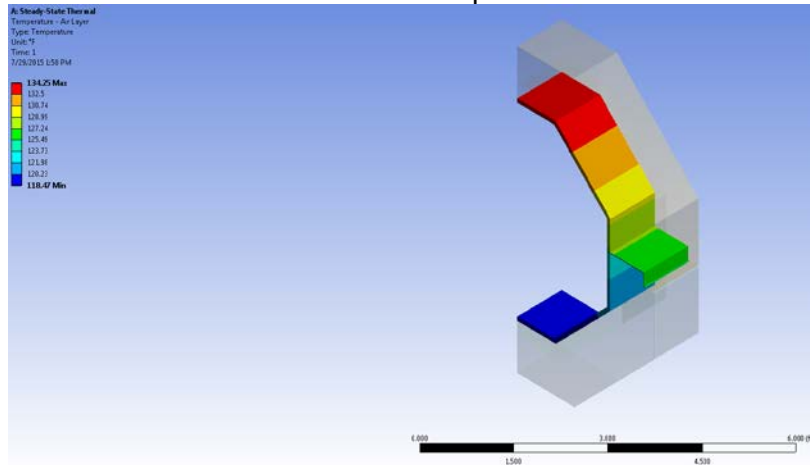

Fig. 4. Kevil Kougar Overpack NCT Temperatures.

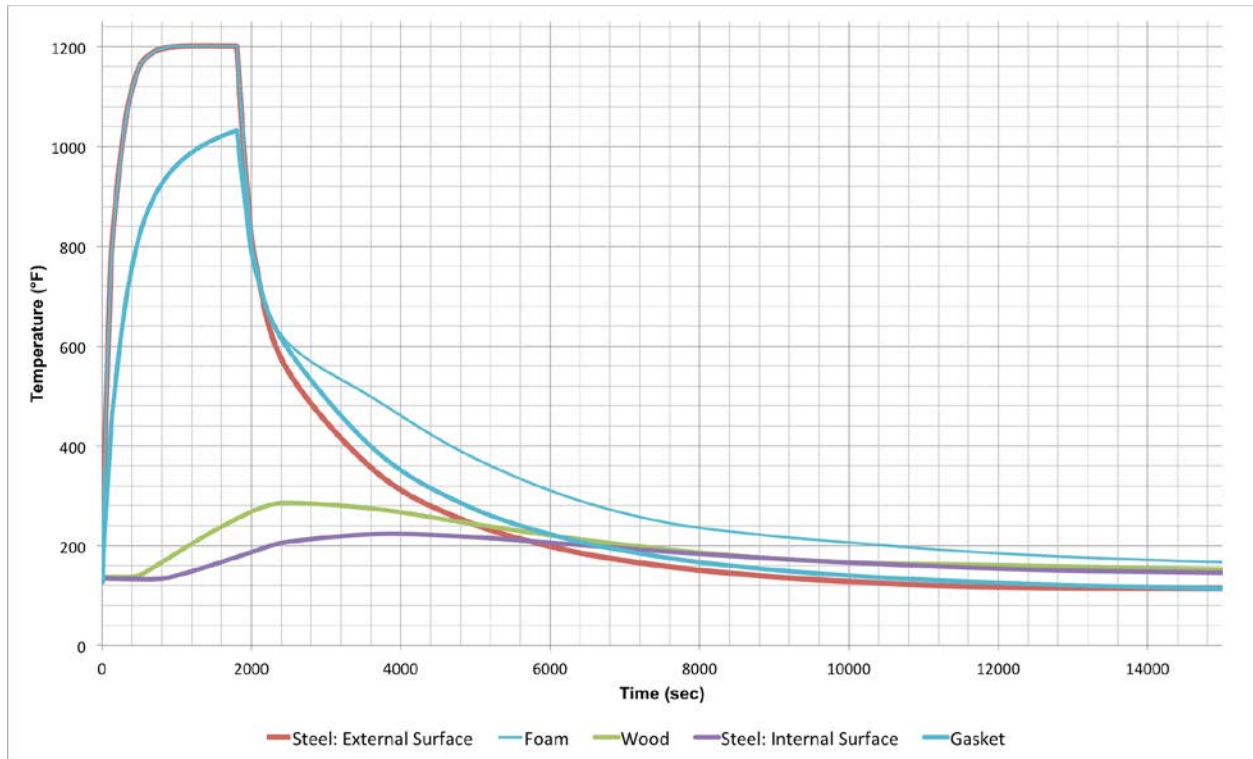

Fig. 5. Kevil Kougar Overpack HAC Temperatures.

The following conclusions are made based on the thermal analysis results:

- The Kevil Kougar Overpack design provides adequate thermal protection of the 48-inch cylinder and UF<sub>6</sub> contents.
- The NCT results show that the package meets the exclusive use requirements of 49 CFR 173.442 [3].
- For both NCT and HAC, the internal air temperature does not exceed the 235°F for the limiting UF<sub>6</sub> cylinder design per ANSI N14.1 Section 5.1.1 [1].
- For both NCT and HAC, the plug temperature does not exceed 250°F per ANSI N14.1 Section 8.4.1 [1].

### Impact test

The impact test is conducted using the LS-DYNA explicit finite element dynamic simulation program [6] to study the structural response of the package during free drop conditions per USDOT [3] Type A requirements. The impact analysis considers extreme ambient temperature conditions (-40°F and 150°F) and various drop orientations (shown in Figure 6) to study the worst-case scenario.

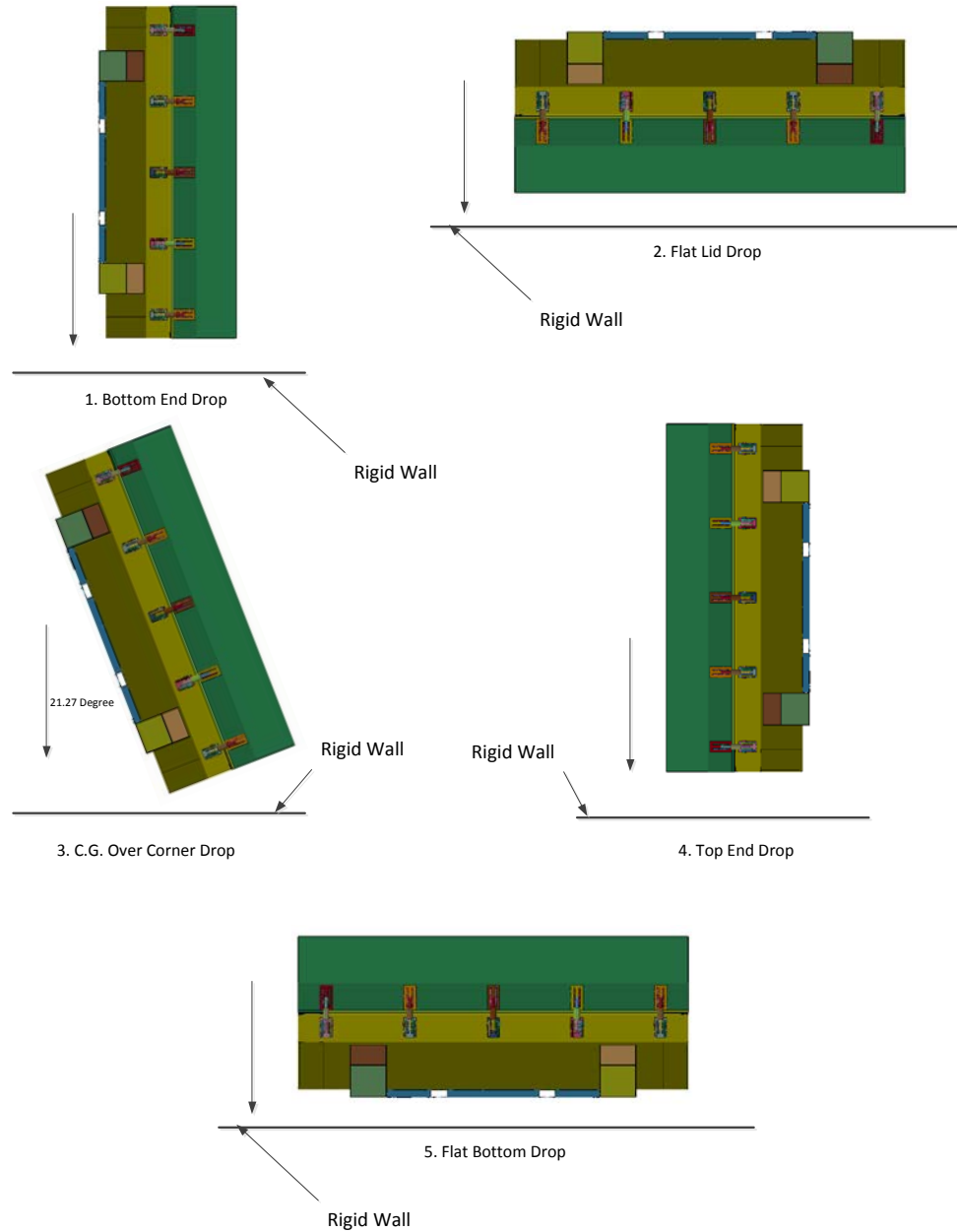

Fig. 6. Kevlar Kougur Overpack Impact Analysis Drop Orientations.

The structural analyses of the Kevlar Kougur 48-inch  $UF_6$  cylinder overpack during the free drop conditions specified by 49 CFR 173.465 [3] show that the packaging provides adequate structural protection for the cylinder and valve. The acceleration and deformation results of the impact analysis are documented in Table I for all drop conditions. Further the valve is evaluated for structural integrity per ASME Section III, Division 2, Service Limit Level A [7] and analysis results show that the valve can withstand the stresses due to the accelerations.

Table I. Summary of Drop Cases

Case No.	Description	Drop Orientation	Predicted Valve Acceleration (G)	Foam/Wood Deformation (in.)	Notes
1	Cold, Light	Bottom End	8.74	2.60	--
2	Cold, Heavy	Bottom End	--	--	Bounded by Case 1
3	Hot, Heavy	Bottom End	8.08	2.90	--
4	Hot, Light	Bottom End	--	--	Bounded by Case 3
5	Cold, Light	Flat on lid	17.86	2.45	--
6	Cold, Heavy	Flat on lid	--	--	Bounded by Case 5
7	Hot, Heavy	Flat on lid	14.37	2.69	--
8	Hot, Light	Flat on lid	--	--	Bounded by Case 7
9	Cold, Light	CG Over Corner	4.87	4.73	--
10	Cold, Heavy	CG Over Corner	--	--	Bounded by Case 9
11	Hot, Heavy	CG Over Corner	3.64	6.30	--
12	Hot, Light	CG Over Corner	--	--	Bounded by Case 11
13	Cold, Light	Top End	5.74	3.19	--
14	Cold, Heavy	Top End	--	--	Bounded by Case 13
15	Hot, Heavy	Top End	5.38	3.50	--
16	Hot, Light	Top End	--	--	Bounded by Case 15
17	Cold, Light	Flat on bottom	14.06	1.00	--
18	Cold, Heavy	Flat on bottom	--	--	Bounded by Case 17
19	Hot, Heavy	Flat on bottom	11.48	1.19	--
20	Hot, Light	Flat on bottom	--	--	Bounded by Case 19

## KEVIL KOUGAR TRANSPORT FEATURES

The focus of the Kevil Kougar packaging design process was to create a package that facilitates the safe transport of 48-inch UF<sub>6</sub> cylinders, but incorporates features that are simple to use and convenient for package operations. The major transport features include internal support and positioning, closure mechanism, and lifting and tie-down system. The transport features incorporated in the Kevil Kougar design provide a secure and robust packaging system, that offer straightforward handling during loading, transport, and unloading.



## Internal Supporting/Positioning Features

The Kevil Kougar is designed to allow the 48-inch cylinder to be loaded in either direction, with or without a valve protector assembly. Twelve rubber support pads (six each in the upper and lower subassemblies) provide internal cushioning support, cradling the cylinder during transport.

The channels and channel pockets cut into the interior cavity of the upper and lower subassemblies and provide positioning support. These channels and channel pockets accommodate the majority of historic and current 48-inch cylinder types. The channel pockets prevent cylinder rotation during normal transport, and in the event of a drop incident, the channels hold the stiffening rings, and therefore the cylinder, in place axially.

Finally, vertical stabilizing beams are installed at each end when transporting the shorter 48X or 48G cylinder. The support pads, channels, channel pockets, and stabilizing beam in the lower subassembly are shown in Figure 7.

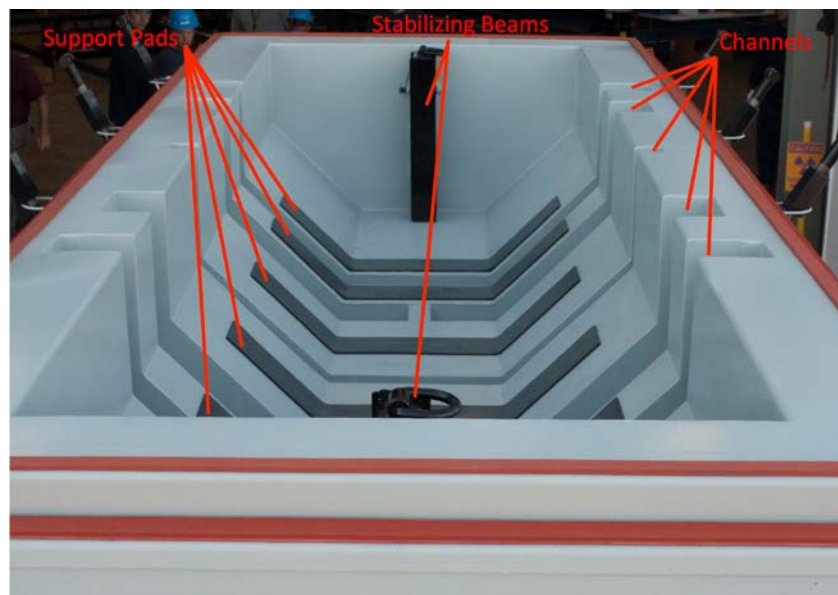

Fig. 7. Kevil Kougar Lower Subassembly Interior.

## Closure

The positive closure toggle swing bolts, equally spaced on either side of the overpack, provide a secure closure mechanism for the Kevil Kougar overpack. The toggle bolts are mounted on the lower toggle assembly. For closure of the overpack, the T-bolt head seats in the upper assembly bracket. The toggle arm is swung down and locked in place with a lock-pin. The toggle bolt assembly is designed such that under conditions normally incident to transport it will remain closed, protecting the cylinder. Toggle bolt assembly is shown closed in Figure 1

and open in Figure 8.



Fig. 8. Kevil Kougar Closure Toggle System.

## Lifting

The Kevil Kougar is equipped with top fork pockets, four lifting lugs and bottom fork pockets for positioning and lifting operation. The fork pockets are operated with the use of an appropriate forklift and the lifting lugs are operated with the addition of lifting eyes and hooks and the use of a crane. The bottom fork pockets are used for positioning or lifting of the bottom subassembly and the entire package. The top fork pockets and the four lifting lugs are used only in the installation or removal of the upper subassembly.

Once the upper and lower subassemblies are joined together, the top fork pockets and the four lifting lugs are rendered inoperable and the entire package can only be lifted using the bottom fork pockets. The functionality of the top fork pockets is disabled with the insertion of pins through the pocket holes and the lifting lugs are rendered inoperable with the removal of the lifting eyes and a cover that falls over the holes of the lugs. Figure 9 shows the upper subassembly lifting features in use.

Upper subassembly lifted with fork pockets



Upper subassembly lifted with lifting lugs



Fig. 9. Lifting the Kevil Kougar Upper Subassembly.

### **Tie-Down**

The Kevil Kougar package is properly secured to the conveyance using ISO locks. The Kevil Kougar design includes four ISO lock receivers welded to the outside corners of the base to facilitate secure mounting to a conveyance.

### **CONCLUSIONS**

The Kevil Kougar overpack is currently licensed to ship depleted and natural uranium in an ANSI N14.1 and ISO-7195 compliant 48-inch cylinder via road, rail, or ocean. The packaging is designed for safe transport of all contents with simple and convenient requirements operationally. Future activities for the Kevil Kougar include licensing the package as Type AF to facilitate transport of historic US Department of Energy fissile material packages.

### **REFERENCES**

1. American National Standards Institute (ANSI), "American National Standard for Nuclear Materials - Uranium Hexafluoride - Packagings for Transport," ANSI N14.1, 2012.
2. International Organization for Standardization (ISO), "Nuclear Energy - Packagings of Uranium Hexafluoride (UF<sub>6</sub>) for Transport," ISO 7195, 2005.
3. United States Department of Transportation (USDOT), "Title 49, Code of Federal Regulations Part 173, Subpart I - Class 7 (Radioactive) Materials," 2016.
4. IAEA, Advisory material for the IAEA regulations for the safe transport of radioactive material, 2012th ed., IAEA, Ed. Vienna, Austria: International Atomic Energy Agency, 2014.
5. ANSYS Inc., ANSYS Version 14, 2015, Finite Element Analysis Software.
6. Livermore Software Technology Corporation, "LS-DYNA, A Program for Nonlinear Dynamic Analysis of Structure in Three Dimensions," 2013.
7. The American Society of Mechanical Engineers, "ASME Boiler and Pressure Vessel Code, Section III, Division 2, Rules for Construction of Nuclear Facility Components.," New York, 2010.