

A Model from the Mind to the Operating Facility – 16448

Paul Jennings *, John-Patrick Richardson *, John Rowley **

* National Nuclear Laboratory

** Sellafield Ltd

ABSTRACT

The reprocessing of Spent Magnox fuel has been undertaken at the Sellafield site in the United Kingdom (UK) for more than 50 years and is now entering the final few years of its operating programme. The age of this facility has resulted in additional operational challenges which have led to the need for a sustained programme of continuous improvement. It has therefore been necessary to assess what potential plant improvements are key to delivering a successful end to the operating programme.

In 2003 the UK National Nuclear Laboratory (NNL) (then Nexia Solutions) worked with Sellafield Ltd to produce a visual discrete event simulation (DES) model. The DES approach models plant equipment (such as a storage pond crane or fuel element processing equipment), and the key processes that these items undertake. Process times, availability and process logic are all combined to provide a prediction of the plant performance. Through the use of 'what-if' scenarios, changes to any model parameter can be undertaken.

The benefits of such an approach have been in the ability for Sellafield Ltd to understand which changes to make and which do not add value. This then allows the operating facility to focus the improvement programme on quantitatively underpinned benefits, thus increasing the potential to complete the reprocessing programme ahead of schedule, which is a key aim for Sellafield Ltd.

Maximising the benefit of this model has required a close working relationship between NNL, Sellafield Ltd Technical and the Sellafield Ltd Operations teams to ensure that the model is using the correct information and is addressing the real issues at hand.

Over the past 12 years many ideas have been assessed and three examples have been selected to demonstrate the range of use of the model, and the different approaches used to identify issues and opportunities, agree an approach and provide solutions.

INTRODUCTION AND BACKGROUND

For over 50 years Sellafield Ltd has supported the United Kingdom (UK) nuclear industry in the reprocessing of metallic Uranium fuel. Reprocessing is the only proven lifecycle approach for the management of irradiated Magnox fuel. The process delivers passive, safe products using existing facilities across Sellafield Ltd.

There are only a small number of Magnox-fed nuclear reactors in the UK that are still to be emptied of fuel. All of the remaining Magnox fuel will be sent to Sellafield

Ltd for reprocessing.

The facilities at the Sellafield site that have supported reprocessing are ageing due to the long time period of operations. These ageing facilities have led to a reduction in the amount of fuel that is reprocessed each year. Similarly, as the reprocessing programme heads towards completion, the challenges in reprocessing increase due to additional restrictions, such as the order that fuel can be fed, and the space that is available in the Fuel Handling Plant (FHP).

Sellafield is a large and complex nuclear site that undertakes numerous nuclear related programmes, of which Magnox Reprocessing is just one. Due to this complexity and the age of the site, the reprocessing facilities are not located next to each other. This increases the challenge of the Magnox Reprocessing programme as nuclear material needs to be transferred across the site (such a movement is displayed for example in Fig. 1), which takes time and requires scheduling so that it does not delay other Sellafield programmes.

Sellafield Ltd is government funded, as such there is always a need to drive the facilities and the programmes to undertake work more efficiently and deliver earlier. As there is only a finite amount of fuel left to be reprocessed, it means there is a finite number of days left of reprocessing. Any increase in throughput will lead to a reduction in the number of days of reprocessing left. Every day that the reprocessing programme finishes earlier is a significant cost saving to the UK government.



Fig. 1. The Fuel Handling Plant at Sellafield Receives Spent Nuclear Fuel from Magnox and AGR Power Stations across the UK, Supporting Clean-Up Operations

USE OF DISCRETE EVENT SIMULATION

To understand how to address these challenges and determine where funds are best directed, it was necessary to build a model to simulate the system, so that the UK National Nuclear Laboratory (NNL) could undertake 'what-if' scenarios trying out different ideas at a fraction of the cost of making the changes on the real facility, and obtaining the results much quicker.

The simulation approach used is called 'Discrete Event Simulation' (DES) which is a technique that models a system (nuclear plant, hospital, bank, etc.) by stepping through set events sequentially, checking a set of rules in order to determine how to respond and then progressing to the next event. This approach has been used extensively in the nuclear industry, and a DES model of nearly every major facility at Sellafield was used to support design, or is now being used to support operations (starting with the design of the Thermal Oxide Reprocessing Plant (THORP) in the 1980s).

At the core of the discrete event model is a series of parts (e.g. skips, rods, and flasks); machines (e.g. decanners, cranes and locomotives); and buffers (e.g. park stands, vessels and ponds). A set of rules are then coded into the model to describe how a part moves through this system, how long a part takes to process through a machine, and how large the buffers are. The logic encoded into the model matches the operating strategy of the facility, covering rules such as the work priority when multiple different options are available (e.g. skip handler moves).

By running a simulation model results, such as the total time to complete reprocessing and the utilisation of equipment or labour resources, can be predicted. Operating the model with different parameters (e.g. process times) allows for a comparison between options to support the case for investment.

A key feature of a DES model is the ability to include random events such as breakdowns. Due to these random events the outcome of the model can change, even when using the same input parameters. Repeating this many times with different random numbers will give a range of results, and it is this range that is compared between options.

The simulation model software used by NNL, called WITNESS, has a visual interface which enables the user to watch the fuel as it moves through the plant. The 'machines' are colour coded so that they turn red when they break down, yellow when they are idle waiting for work, pink when they are 'blocked' and cannot feed forward to the next machine, and green when they are operating. Just watching a simulation in progress can provide a great insight into the operations of a complete facility, something that isn't possible from the plant floor.

FROM THE MIND TO THE OPERATING FACILITY

The Magnox Reprocessing Simulation model has been used since 2003 to investigate a range of challenges facing the facility. Each time a standard approach

is used, although the details may change. Although this may not be a unique process, key aspects of the application have made this approach very successful over the past 12 years.

From the Mind to the Model

1. Identify the Issues

The identification of an issue, a challenge or a potential opportunity will occur through discussions between Sellafield Ltd Technical and the Operation Managers. At the start of a financial year, they could pro-actively look at the challenges ahead and ask what is concerning them as an Operations Manager? At a later point in the year, something may have then occurred, or a new opportunity been identified to investigate.

As the Intelligent Customer (IC) for the model, Sellafield Ltd Technical can understand what the model is capable of, and also what it cannot do. This perspective is important to stress, in so far as it is often just part of the jigsaw of making changes in a nuclear facility. Other factors not considered by the model on its own must be taken into account; such as safety, criticality and chemistry. Given the position of the IC, they are also aware of other tools in their 'tool kit' which may be more applicable to the problems facing the Operations Manager.

At the end of this meeting, modelling questions would have been generated. These are often to quantify the changes anticipated – modelling seldom highlights unexpected results. Plant Managers have extremely good understanding on how the plant will operate when a change is made, however only through detailed modelling can the full complexity be taken into account, and a final quantified impact then made.

Into the Model

2. Agree Modelling Approach

Following the discussion between Plant Operators and Sellafield Ltd Technical, NNL as model developers and analysts are brought into the discussion. This may involve further discussions with the Plant Operators, or could only involve Sellafield Ltd Technical and NNL. Here the value of an IC comes into play again, as this first discussion (once the requirement has been explained) is about how this requirement/s can be included in the model.

As stated previously, a model can only be an approximation, which needs to be re-assessed each time the model is used for a new question – is it still fit for purpose? Through pooling the knowledge of Sellafield Ltd and NNL, a good assessment as to whether the current assumptions and simplifications are sufficient, or whether changes are necessary, can be made.

3. Data Gathering

To successfully model, the facility data is required. This could be process logic, process times and availability data. Sometimes this information is already contained within the model, whilst at other times data collection is required. Using the template agreed between Sellafield Ltd Technical and the developer, the correct information can be gathered to progress to model development.

4. Develop Model

Even during the development phase, discussions between developer and IC need to continue. During development additional questions can be raised, often as unexpected situations occur which need some logic built into the model e.g. "what happens when...?" Other discussions can be centred around difficulties in making a modelling change, such as the value in exactly modelling plant operations are continual questions to consider - "does such detail really make any significant difference"?

Finally the model is verified, independently of the model developer, and all of the assumptions are compared with the operations of the model.

Model Analysis

5. Analysis

Once the assumptions have been agreed, and the model verified, the scenarios can then be run. However, the answers generated cannot be taken at face value – did we make the correct assessment in our simplification? Do the results look sensible? Pooling the knowledge of Sellafield Ltd and NNL, any unexpected results can then be double checked.

Fortunately a DES is not a black box - as the model runs, the user can view the whole operating system holistically, stepping through events hundreds of times faster than reality. In doing this features can be understood – questions such as "why is the utilisation of equipment so low?" or "how busy is the facility as a whole?" can be, and have been, answered by reviewing the model in this way.

This gives strength to the understanding of why the system gives the results it does. This is very useful when facing the challenges of the Sellafield Ltd Magnox Reprocessing Technical Committee, as unexpected answers are seldom taken at face value.

Model to Operating Facility

6. Feedback to Operations

As stated previously, feeding back the results just forms part of the story. Improvements have to be combined with cost and safety assessments. At this point, this is back in the hands of Sellafield Ltd, who are now empowered with greater knowledge of the quantitative impact realised by the proposed

improvement. Key messages for Sellafield Ltd are not just those changes that improve the facility but those areas in the reprocessing facility which are insensitive to change. This enables the improvements team to focus improvements on a small number of key areas rather than a broad approach.

CHALLENGES AND OPPORTUNITIES IN MAGNOX REPROCESSING

This section covers the history of the model, showing the range of issues addressed, how the process in the previous sections has been applied, and examining in detail a few of the key issues.

2003 – 2007 FHP Model

The initial simulation model was developed in 2003 and just covered the FHP. The purpose of the model was to investigate the throughput of the whole of the FHP, in isolation from the rest of the system. This was due to a perception at the time that this part of the system was a bottleneck, and to determine the performance of the whole of Magnox Reprocessing, this facility needed to be improved. The key objectives of this original model were;

- To determine the feasibility of alternative production schedules being able to meet the required production volumes;
- To develop and evaluate alternative operating rules for the skip handling component of the FHP, with a view to increasing throughput; and
- To identify bottlenecks and evaluate the effect of increasing equipment availability (Overall Equipment Effectiveness - OEE) on throughput.

The model was then extended to investigate the interactions between the Magnox Operations and Advanced Gas-cooled Reactor (AGR) Operations, as both occur in FHP using the same import route, main pond and skip handler.

However, it was realised that there was a closely coupled operation with the Chemical Separation Plant (CSP), and that railways were an integral part of this link between the two plants. Therefore a new model to complement this one was proposed.

2007 Magazine Model

1. Identify Issues

In discussions with the operating teams, Sellafield Ltd Technical department identified that there was no clear obvious bottleneck within the Magnox Reprocessing process stream. This resulted in a number of different improvement programmes, with the aim to improve individual facilities rather than the reprocessing stream as a whole, to achieve agreed targets.

However with such a large complex facility it was not obvious how to identify the best changes to make, as each system within the whole facility operated independently of each other. In fact to each system, it appeared that the other systems were always holding themselves up.

2. Modelling Approach

Building on the success of the previous work, it was agreed that a model that combined the FHP, railways and chemical separation was required. Initially this was a totally new model, using the same software as the original FHP model, but starting at the stage where the decanners become utilised in reprocessing.

Discussions were held between Sellafield Ltd Technical and NNL on whether to extend the existing model, or create new, separate models. A new model of the reprocessing system was commissioned to understand the process better, and to look for potential improvements.

3. Data Gathering & Model Development

As a whole new model was being developed, a large amount of assumptions, process times and availability data was required. Therefore interviews with the respective plant managers were held, including personnel from within both Sellafield Ltd Technical and NNL. Where possible, existing plant logs were used, but in a few cases, actual timings of operations were undertaken, with the full agreement of the plant managers.

Fig. 2 contains a screenshot of the new model layout, displaying the various interactions between the FHP, railways and CSP, so that once a model is running, clearly shows the user what is happening in each module of the model build.

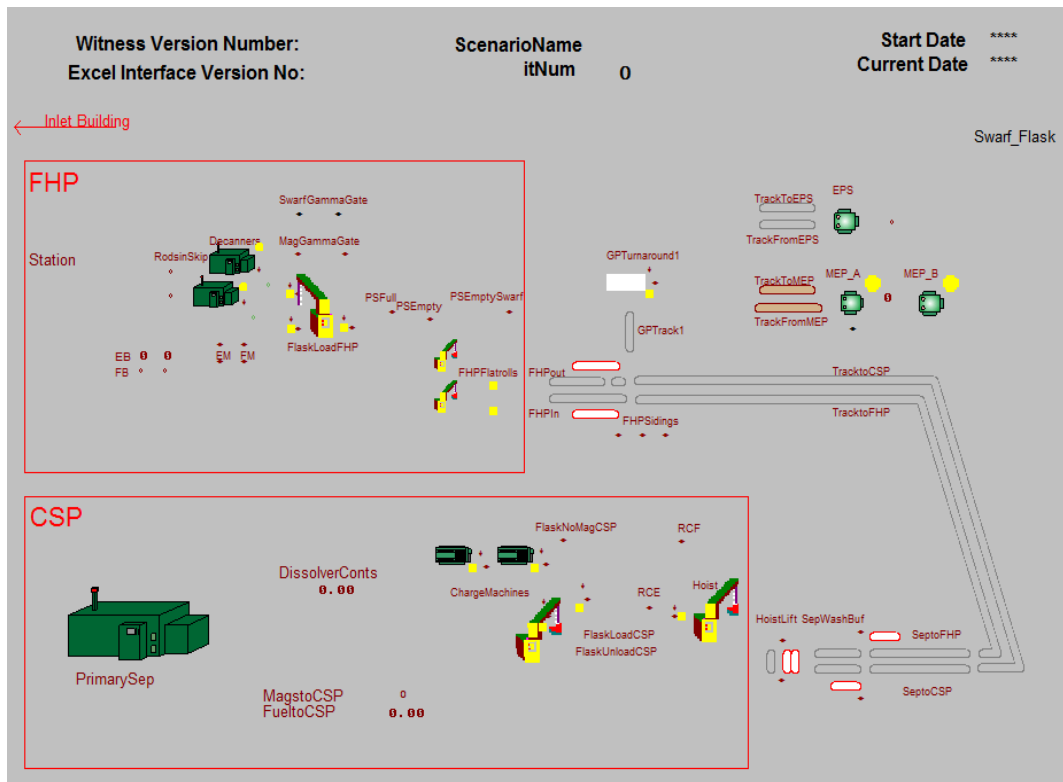

Fig. 2. Magazine Model Designed to Address Throughput / Facility End Date, and Identify and Support Improvement Initiatives

4. Analysis

Extensive analysis was undertaken with the new model, although one of the most useful features was the visual interactive element. By just watching the model operate, it was easy to see how the view that “everyone else was the bottleneck” could come about. With very little buffer capacity between the three systems, it didn’t take long for one system to fail before the other two systems were either blocked, or starved of fuel to continue reprocessing.

Additional sensitivity analysis was undertaken to look for improvements that had the biggest impact on the whole of Magnox Reprocessing, as opposed to just improving one system in isolation. These ideas came from two sources; from the NNL modelling team (trying out different modelling parameters, and using experience from watching the model operate), and also from plant managers, asking how much improvement in throughput a given change would make.

Below are a few examples of improvements which were examined using the model.

4.1. Train Speeds

One option put forward by the operations team was to increase the speed of the trains. They had been operating at 4 miles per hour, and the safety case was written based on this speed. It was felt that the GPT trains could be safely run at 8 miles

per hour, which would (almost) half the time taken to transfer fuel between the two facilities (FHP and CSP).

However, this would require the safety case to be re-written, so before incurring the expense of re-viewing and re-writing the safety case, operating instructions, and everything else that would be required for such a change, it was agreed to check the predicted benefit through the model. By running this simple change through the model, it forecast that improvement in throughput would be achieved, and so the change was implemented within the year following all of the safety case review and related changes.

4.2. Crane Logic

At the CSP there is very limited space for magazines to be stored. In order to bring in a full flask and exchange it with an empty flask, this always required shuffling around of flatrolls and flasks. Plant operators identified three possible approaches, and manual calculations utilising a Gantt chart showed which should have provided the fastest turnaround, without taking random events into account.

However, once breakdowns and irregular fuel deliveries from the FHP were taken into account, it was questionable which would be the best, most robust approach. Through modelling all three approaches, it was possible to demonstrate that the new approach suggested by plant management was also the most robust. The model had confirmed the 'gut feel' of experienced managers.

4.3. System Availability

It was obvious that improving system availability, by either repairing equipment quicker or ensuring that there were longer gaps between failures, could only improve overall throughput. However, to determine which changes had the greatest impact would have been guesswork without using the model. The model was used to provide a series of graphs showing the sensitivity of throughput to changes in availability. Plant management could then use this information to determine which change was best value for money.

4.4. Magazine Numbers

Further sensitivity was undertaken to look at the number of magazines and flasks available to use across the system. A simple set of scenarios were set up, which showed that there was little benefit in increasing the number of flasks and magazines in use. However it did show a 'cliff edge' that if any of the existing fleet were taken out of service, then throughput would reduce significantly.

4.5. Unblocking Magazine Tubes

Manual calculations by Sellafield Ltd Technical identified that a simple solution of unblocking blocked magazine tubes could have a significant improvement in throughput. This would increase the carrying capacity of the railways, as the quantity of fuel that was moved on each journey would increase with no impact on

the journey itself. However, it would take longer to fill each magazine and empty it as more fuel was present. The model was then used to quantify the benefit of this action, which resulted in an increase in throughput.

4.6. Combined Improvements and Improvement Programme

The model was then used to look for synergies between improvements. It became apparent that some improvements had the biggest impact, if combined with other improvements. This identified that when a system was no longer a bottleneck there was no value in making further improvements, until the other bottlenecks 'caught up' with the performance of the original system. This outcome was very clear, and could assist Sellafield Ltd Operations with developing an improvement programme, demonstrating the value in early improvements, and the impact of delaying improvements.

5. Feedback

All of these improvements outlined, and more, were fed back to the Sellafield Ltd Operations management through presentations and technical reports. Some improvements, such as the crane logic, did not impact on the operations on plant, as this confirmed that the recent change made was the right one to make.

Other improvements could be acted upon immediately, such as the unblocking of tubes, and others required further supporting evidence, such as confirming that it was still safe to increase the speed of the trains. However not all suggested improvements were acted upon. As previously stated, this is only part of the jigsaw; safety, limited funds, flexibility and other priorities sometimes result in rejection for a suggestion, despite its potential for improving throughput.

2015 Skip Cleaning

The most recent challenge to be addressed using the Magnox Reprocessing model was to investigate skip cleaning, towards ensuring that all empty skips within the fuel storage pond have been cleaned prior to the completion of Magnox Reprocessing.

1. Identify Issues

Skips which previously contained fuel need to be cleared before Magnox Reprocessing is completed. The debris from the cleaning process collected in baskets is mixed with Magnox Swarf, and sent to the Magnox Encapsulation Plant (MEP) for waste treatment. Once reprocessing is complete, this waste route may not be available, and hence the remaining skips cannot be cleaned without finding an alternative waste route.

Previous analysis showed that with the current system parameters, it would be very difficult to finish cleaning all of the skips prior to the end of reprocessing. Sellafield Ltd Technical were therefore approached by the System Engineers, who are

responsible for each operating system within the whole facility, to ask for an improvement target to achieve which would ensure that all skips could be cleaned.

2. Modelling Approach

The model already included nearly everything that would be required to undertake this analysis. Additional options were included, such as allowing cleaning basket containers, and allowing both decanners to be used for basket tipping and sorting. Therefore the key modelling aspect was to ensure that the most up-to-date data was being used, as new information in this aspect of operations was being gathered all of the time.

3. Data Gathering

A workshop was held with plant based experts and System Engineers, in which the full process was walked through, discussing along the way each of the assumptions in the model, how the logic operated, and updating any cycle times as required. Any outstanding issues that couldn't be answered in the workshop were taken away for further data gathering. The final model assumptions document was then updated and signed off by all relevant parties.

4. Model Development and Analysis

Model development, and reporting, was undertaken in two phases. Initially just the new parameters were updated, and a technical report was rapidly presented back. However, this didn't include the additional options for operating the facility. This highlighted the need to include these additional options as the number of skips remaining to be cleaned was not acceptable, even with significant improvements in process times and availability. Therefore a second round included further (minor) model developments.

Fig. 3 contains a screenshot of the updated model layout, including the inlet cells, skip handler, sub ponds, and decanners. When the model is running, each element provides the user with a live status of where a skip is in the model at any one point, and what is happening to it via colour changes to the display, as well as numerical displays of what types of skips have been processed, and how many, after a user defined time period.

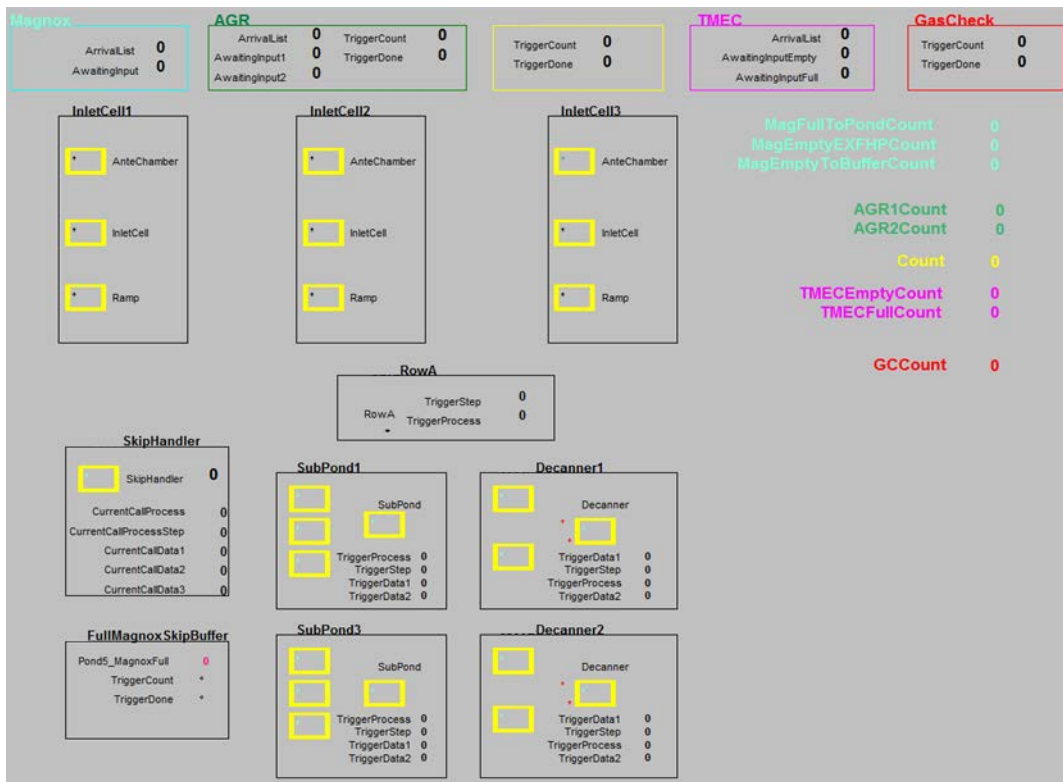

Fig. 3. Cleaning Baskets Enabled Forecasting Ability to Accept Historic Fuel and Directing Trials

5. Feedback

Feedback has only been very recently received at the time of writing this paper, so discussions are still underway as to how to use this information within the model. Although this work is not yet complete, the output of this work will be system targets that the System Engineers can work towards, and assess whether improvements are needed in their own systems.

Options have been provided with no single recommendation. As stated previously, the model cannot assess how easy it is to make any change. The model can provide the level of change in process times and availability to achieve say a 10% improvement in throughput, and the Operation Managers can then decide which is the easiest way to achieve this 10% improvement.

2007 - 2015

The model has been used every year since it was first developed in 2003. In some years only sensitivity analysis has been required by Sellafield Ltd Technical, with no change in model assumptions or logic. In other years, new modules have been added, such as modelling the fuel pond in detail, to examine the benefit of moving to triple stacking of skips in the pond.

Every year requests for analysis are received direct from plant managers during the middle of the year; such as “what would be the impact of operating with five additional specific fuel skips in the pond, instead of two?” With the model up to date and fully validated, these questions can be quickly answered, and the value of the model as an ongoing tool continues.

CONCLUSIONS

There are two key conclusions which can be drawn from our experience over the past 12 years. Firstly DES is a very powerful tool, which can address a wide range of issues over the whole lifetime of plant operations, as well as the traditional use during plant design.

Secondly, to make best use of the model, close collaboration between the technical department and the model developer is required. This modelling programme has been a template for a way of working between Sellafield Ltd and NNL, with the Sellafield Ltd Technical department providing the IC role, which has been crucial to the success of this approach.

This model will continue to be used to assess improvements and track progress as the Magnox Reprocessing programme heads towards completion at Sellafield.