

Sellafield FGMSP Additional Sludge Retrievals

A Significant Step in Decommissioning Part of the U.K.'s Nuclear Legacy - 16180

Ian Grant
Westinghouse Electric Company
Galemire Court, Westlakes Science & Technology Park, Moor Row, Cumbria, CA24 3JZ, UK
Tel: +44 (0)7976 492811, Email: grantid@westinghouse.com

Udo Weintrager
Westinghouse Electric Company
Dudenstrasse 6
68167 Mannheim, Germany
Tel: +49 621 388-2468, Email: weintru@westinghouse.com

Ian E Richardson
Sellafield
Seascale Cumbria, CA20 1PG, UK
Tel: +44 (0) 19467 88346, Email: ian.e.richardson@sellafieldsites.com

Mike Gull
EnergySolutions
Kelton House, Westlakes Science & Technology Park, Moor Row, Cumbria, CA24 3HX, UK
Tel: +44(0)1946599977, Email: mjgull@energysolutions.com

Dave Wilson
EnergySolutions
Kelton House, Westlakes Science & Technology Park, Moor Row, Cumbria, CA24 3HX, UK
Tel: +44(0)1946599977, Email: drwilson@energysolutions.com

ABSTRACT

The First Generation Magnox Storage Pond (FGMSP) is an open-air pond on the Sellafield site (U.K.) constructed to receive and store spent nuclear fuel from the UK's fleet of Magnox reactors. Operations ceased in 1986, leaving a significant mobile (sludge from the corrosion of fuel cladding) and solids (fuel, fuel fragments and other debris) inventory. In December 2013, Westinghouse Electric Company and EnergySolutions proposed to create an Additional Sludge Retrieval (ASR) capability, with the aim of starting sustainable sludge transfer and hazard reduction as soon as possible.

The ASR project team proposed a sludge retrievals concept based on the use of a self-propelled, remote controlled Floating Platform. The deployment system was derived from a Floating Platform concept developed by Westinghouse to support field operations in European nuclear power plants. The system was designed, manufactured and successfully tested in real scale conditions, and was installed and fully commissioned in March 2015.

INTRODUCTION

The First Generation Magnox Storage Pond (FGMSP) is an open-air pond constructed during the 1950s and 1960s on the Sellafield site in the U.K. to receive and store spent nuclear fuel from the UK's fleet of Magnox reactors, and to remove the fuel cladding prior to the fuel being processed. Over the years the pond has accumulated significant quantities of waste materials, sludge from corrosion of fuel cladding, fuel fragments and other debris which has blown into the pond, and skips of fuel.

Sludge consists primarily of Magnox corrosion products and deposition of windblown material including sand. It is predominantly magnesium hydroxide but in some areas, contains significant quantities of uranium (fuel) corrosion products. Any uranium fuel material less than 6 mm (nominal) is considered part of the sludge inventory. Other materials are believed to be present (such as organic materials, algae, grease, graphite, Zircaloy, aluminium and lead), but in very small quantities.

Sludge has settled at varying depths and locations in the main pond areas.

The start of sludge retrieval from FGMSP is an important milestone of the FGMSP remediation programme. A dedicated facility called Sludge Packaging Plant (SPP1) was erected by Sellafield Limited (SL) to receive sludge from FGMSP. SPP1 mainly consists of three settling tanks, designed to receive sludge from FGMSP and return supernate to the pond at pre-defined flow rates.

In December 2013, Westinghouse Electric Company and Energy*Solutions* proposed to create an Additional Sludge Retrieval (ASR) capability, complementing the objectives of the main Bulk Sludge & Fuel Retrievals (BS&FR) equipment in delivery, with the aim of starting sustainable sludge transfer and commencing active commissioning of SPP1 as soon as possible.

SCOPE OF WORK

The objective of the ASR project was to initiate sludge retrieval as early as possible to maximize the use of the SPP1 sludge settling tanks (Fig. 1) which were scheduled to be ready to receive sludge from FGMSP on 28th November 2014.

SPP1 essentially consists of three 450m³ tanks, designed to collect sludge from FGMSP, let the liquor settle and return supernate back to the FGMSP pond. At the start of the ASR project, SPP1 had been constructed and a pipe bridge was linking the facility to FGMSP.



Fig. 1. SPP1 Sludge Settling Tanks

A specific area of FGMSP, called Inlet Sub Pond (ISP), was selected to start sludge retrievals. This area was chosen on the basis of its relatively accessible sludge layer as well as because the main sludge retrieval system (BS&FR equipment) had not been designed to cover that area of the pond.

The Skip Handling Machine (SHM) is the only available overhead crane for the whole pond. A major constraint on the design of the ASR system was that it could not interfere with the SHM operation or delay the installation of any of the equipment already planned to be deployed in FGMSP (e.g. the BS&FR system). In particular, the ASR system could not be supported by the SHM in normal operation.

The ASR process parameters also had to comply with the SPP1 acceptance criteria. The acceptance criteria and process requirements resulted in the design parameters listed in TABLE I.

In addition, the ASR system had to be designed to facilitate the replacement/maintenance of individual components, especially those that are likely to be subject to erosion or blockage. Many of these maintenance operations would involve Long Handling Tool underwater operations

Finally the area of focus of sludge retrieval operations (ISP) was also a passageway for the SHM. The ASR system design had to be such that it does not interfere with the SHM Route in the ISP when all the ASR kits are in parking mode.

TABLE I. ASR Process Design Parameters

Design temperature (max)	40 °C
Design pressure (max)	14.8 bar
Required flow rate to SPP1	60 m ³ /h
Allowed particle size to SPP1	< 6mm
Average solids concentration to SPP1	≤ 2.5% v/v
Slurry batches sent to SPP1	80 m ³

Sludge Retrieval Process

In the interest of starting sludge retrieval as quickly as possible, the strategy established by the ASR project team consisted of adapting an FGMSF sludge retrieval process already designed and substantiated by Sellafield Limited (SL) to the specific constraints of the ASR project Functional Specification.

The ASR process uses a centrifugal slurry pump (Grindex Master H), equipped with a 650mm flexible suction hose and strainer nozzle designed to prevent particulates bigger than 6mm from being sucked in the process. The sludge is pumped from the pond floor and pushed through 33 m of 2 inch flexible EPDM hose and an over-the-wall hard pipe to a centrifugal booster pump (KSB KRTF 40-250/82-UHS) at a nominal flow rate of 30m³/h. The slurry is then diluted due to another 30m³/h stream of pond water generated by a dilution pump identical to the booster pump, and directed to one of SPP1 settling tanks via 30m of 3 inch flexible EPDM hose and a section of hard pipe (Pipe Bridge). Throughout the process, slurry runs either through flexible hoses suspended 2m below water level, or through coaxial pipes, so as to ensure that in the event of a breach of primary containment liquor returns to the pond and does not break water surface. The ASR Process Flow Diagram is shown in Fig. 2.

Slurry is sent to SPP1 in batches of 80m³ (including flushing of the slurry lined with pond water). Upon completion of sludge settling, supernate is returned to the FGMSF main pond via a dedicated coaxial pipe. This part of the process is controlled by SPP1.

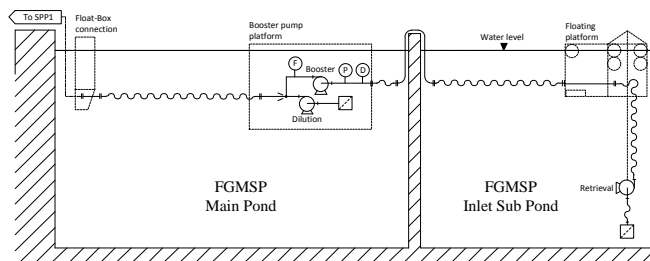

Fig. 2. ASR Simplified Process Flow Diagram

Deployment System

Since the SHM could not be used in normal operation, a self-standing deployment system had to be designed to deploy the ASR equipment in the pond. Based on a review of various deployment alternatives, the ASR project team proposed a sludge retrieval concept based on a self-propelled, remote controlled Floating Platform connected to SPP1 via a Booster Pump Platform. Whilst the process design was based on the BS&FR system, the deployment system was derived from a Floating Platform concept developed by Westinghouse to support outage operations in European nuclear power plants.

The overall layout of the ASR System is shown in Fig. 3. As explained in Section II, the ASR system could not impact normal SHM operations, and therefore, the Floating Platform and the ISP slurry umbilical cord cannot interfere with the SHM Route (shown in green) in parking mode.

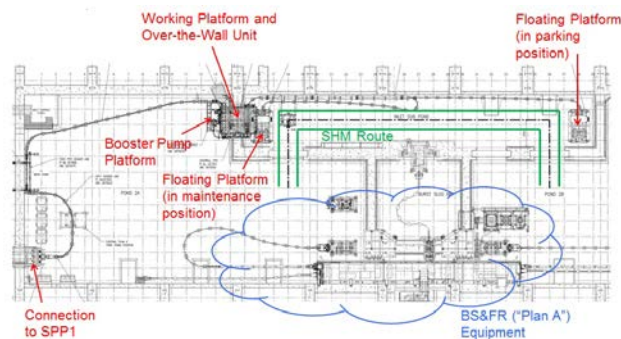

Fig. 3. ASR System Layout

Floating Platform

The Floating Platform is designed to deploy the Sludge Retrieval Pump in the Inlet Sub Pond, and pull the slurry umbilical that connects the Sludge Retrieval Pump to the Booster Pump Skid.

The Floating Platform frame essentially consists of a stainless steel structure, with four bulk-headed floating elements. The frame supports a winch which controls the vertical position of the Sludge Retrieval Pump above the sludge bed, two underwater pan-tilt-zoom cameras, as well as six dimmable LED lights to ensure appropriate visibility of the sludge retrieval operations. The whole assembly is driven by one longitudinal (8.0 kW) and two lateral (4.5 kW) thrusters designed to ensure recoverability of the Floating Platform in case of failure of one of the thrusters.

Most of the features of the Floating Platform are controlled via a Programmable Logic Controller (PLC).

In accordance with the project Functional Specification, the Floating Platform is also designed to be maintainable in situ, i.e. from a Working Platform erected on the ISP

west wall (Fig.10). All of its active components (Sludge Retrieval Pump, Winch, cameras, lights, Thrusters, Electrical Cabinet) are designed to be replaceable using Long Handling Tools from the Working Platform. This required significant design effort in the components locking mechanisms and electrical connections.

Fig. 4 shows a 3D view of the Floating Platform, and shows its approximate position with regards to the pond water line. Fig. 6 shows the Floating Platform in the Integrated Test Pond.

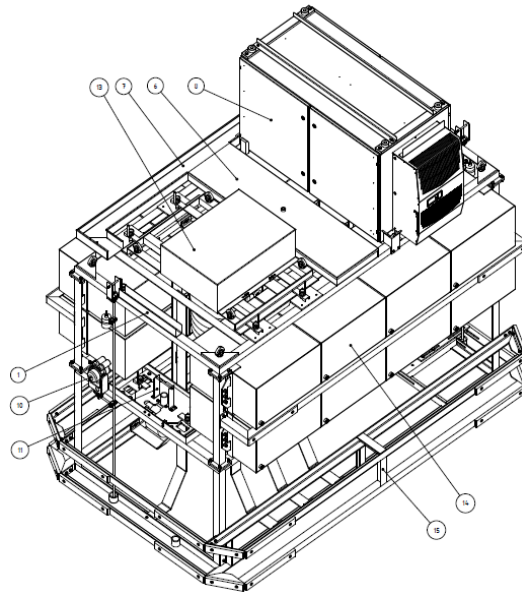

Fig. 4. Floating Platform

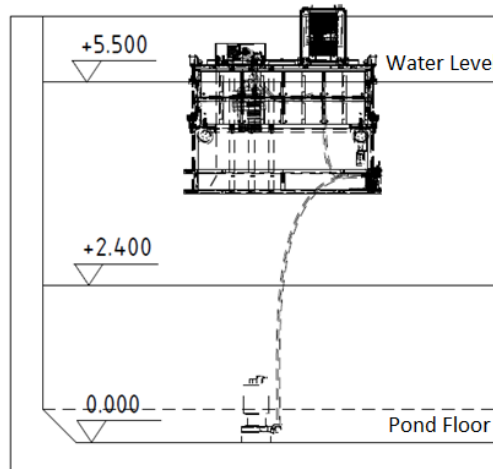

Fig. 5. Floating Platform and Position of the Water Line



Fig. 6. Floating Platform in the Integrated Test Pond

Booster Pump Platform

The Booster Pump Platform (Fig. 7) is another floating structure designed to support the Booster and Dilution Pumps, as well as the necessary instrumentation to control the sludge retrieval process (flow meter, pressure instrument, density meter). The Booster Pump speed is controlled via the flow meter to push slurry at a flow rate of nominally $30\text{m}^3/\text{h}$ whereas the Dilution Pump speed is kept at a pre-determined speed. The Booster Pump Skid is tethered to the Working Platform.

The Booster Pump Platform operation is controlled from the same panel as the Floating Platform. A dedicated Human Machine Interface (HMI) was developed to control the sludge retrieval process. Several pre-defined programs assist the ASR operators in controlling the start-up, retrieval, flush and back-flush operations.

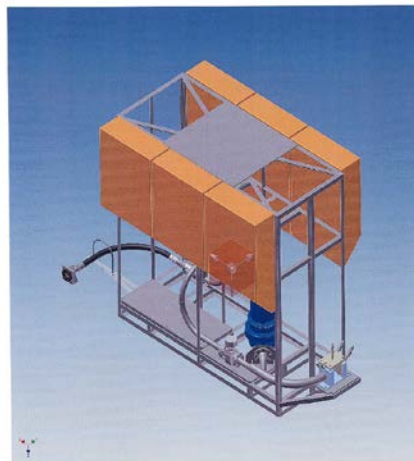

Fig. 7. Booster Pump Platform

Slurry Umbilical's

The slurry is routed from the pond floor to the SPP1 Pipe Bridge via umbilical's similar to the one shown in Fig. 8. The slurry line is made of 2 inch or 3 inch EPDM hoses, suspended 2m below water level from a floatation line. This is to ensure that the sludge does not break the water surface causing a breach of containment. Underwater hose connections (called "wedge block" connections) can be made and broken using dedicated Long Handling Tools either from the Working Platform or from the edge of the pond.

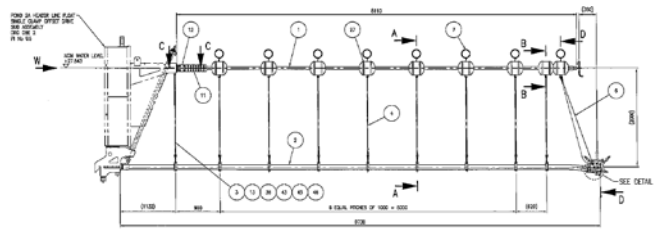

Fig. 8. SPP1 Umbilical



Fig. 9. ISP Umbilical at the Integrated Test Facility

Working Platform

For the purpose of facilitating the installation of the ASR equipment, as well as to ensure the in situ maintainability of the Floating Platform, a Working Platform accessible from the north edge of FGMSF was erected on the ISP west wall, as shown in Fig. 10. The Working Platform stability is ensured by horizontal screw jacks which clamp the structure around the wall.

Two overview cameras are installed on the Working Platform and three Junction Boxes connect the power and Ethernet cables coming from the Floating Platform and Booster Pump Platform to the ASR Control Desk (Fig. 11) located in a trailer installed next to the pond.

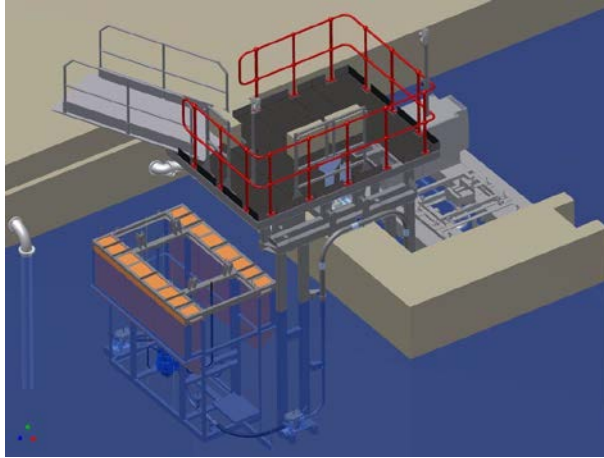

Fig. 10. Working Platform, Booster Pump Platform and Floating Platform



Fig. 11. ASR Control Desk

Integrated Testing

An off-site inactive (22.5m x 10.0m x 6.0m) test pond was secured for the Integrated Tests, which enabled the team to qualify the ASR equipment in quasi real scale conditions. The Integrated Testing programme included the following phases:

- Inactive commissioning of the ASR process, using sludge simulants
- Inactive commissioning of the Floating Platform
- Installation tests for each of the kits using the dedicated lifting beam or frame, including test of the underwater connections
- Test of each of the maintenance sequences
- Training of the ASR operators and maintainers

The installation of the ASR equipment was complex due to the dimensions of some of the equipment, the hazardous nature of FGMSF, as well as by the fact that many of the sequences were totally or partially remote controlled. Among other things,

the creation of reliable deployment methods for the umbilicals has been a significant challenge.

The availability of a large test pond was highly beneficial in terms of optimising the installation methods, as well as providing confidence to all stakeholders of the reliability of the ASR equipment installation sequences.

Installation and Commissioning

Once all required permissioning documents were in place, site installation of the ASR equipment started on 1st February 2015.

After several weeks of installation, the ASR equipment was ready to pump liquor from FGMSP to SPP1 on 13th March 2015. The active commissioning of the ASR equipment and SPP1 was a significant milestone in the remediation of FGMSP.

Sludge retrieval from FGMSP with the ASR equipment is currently in progress (Fig. 12).

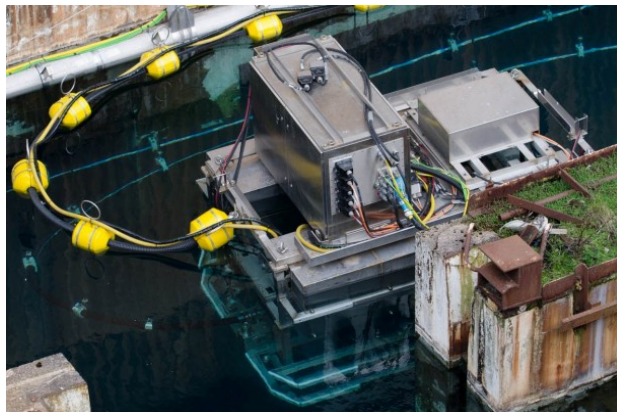

Fig. 12. Floating Platform in FGMSP

CONCLUSIONS

From the original sludge retrieval concepts drawn up in December 2013, the ASR project team developed and implemented a detailed design which was successfully delivered and operating in approximately 12 months by March 2015.

NOMENCLATURE

ASR: Additional Sludge Retrieval

BS&FR: Bulk Sludge & Fuel Retrieval

EPDM: Ethylene Propylene Diene Monomer

FGMSP: First Generation Magnox Storage Pond

HMI: Human Machine Interface

ISP: Inlet Sub Pond

PLC: Programmable Logic Controller

SHM: Skip Handling Machine

SL: Sellafield Limited

SPP1: Sludge Packaging Plant