

Shortage of Type B LLRW Casks in the US to Serve Nuclear Plants and National Labs – 15663

Aleksandr Gelfond, *EnergySolutions*

ABSTRACT

In early 2012, the industry experienced sudden shortage of Type B Low Level Radioactive Waste (LLRW) transport casks available for transportation of nuclear waste and sealed sources within the United States (US) of America. Some of the events which created this situation include, but not limited to, opening of a new LLRW Disposal facility (Andrews County, TX) managed by Waste Control Specialists (WCS) for Class A, B and C LLRW, retirement of vast majority of previously certified Type B LLRW transport packages, more stringent regulatory certification requirements and increased demand for LLRW transportation casks to support decommissioning of nuclear power plant and transportation of sealed sources. Cask designers are still in the process of responding to the emerging needs of the industry. This paper will provide a detailed background and discuss the events that have occurred in recent years that have led to a shortage of Type B LLRW transport casks available to service the industry with transportation of resins, used filters, irradiated hardware and sealed sources. In addition, this paper will provide an overview of currently available, being fabricated Type B packages as well as information about the tentative designs of Type B LLRW transport casks to be designed and certified in the US by cask design/manufacturing firms in the near future. In conclusion section, this paper will summarize whether the LLRW Type B transport cask supply market for discussed payloads will be able to adequately respond to the industry demand. Potential ways for long term resolution of this issue will be discussed.

INTRODUCTION

Since 2008 the industry has experienced a shortage of Type B LLRW transport casks available to safely transport LLRW in the form of resins, used filters, irradiated hardware and sealed sources. There were multiple events that have occurred in the same timeframe that created this situation. Following the formation of Atlantic Compact, which prohibited transportation of radioactive waste from generators outside Atlantic Compact states (SC, CT and NJ) starting from July 1, 2008, there were no Class B and C LLW disposal facilities available to many US states. Many generators from those US states outside the compact were forced to safely store Class B and C LLW in interim storage. This event resulted in a dramatic decrease of radioactive waste transportation needs consequently reducing demand for Type B transport casks. By October 1, 2008 the vast majority of previously certified and used Type B LLRW transport casks, such as 3-55B, 3-82B, FSV-1, 1-13C and 1-13G and 10-142-B were retired, because their Certificates of Compliance (CoC's) had expired and could no longer be renewed. In order to fabricate new Type B casks (under valid CoC) and to comply with the latest international regulations for Type B transport packages, all Type B casks that remained in service had to be upgraded to 1996 edition of IAEA Transport Regulations with designation “-96”. This upgrade resulted in the loss of payload capacity for some of the Type B packages. In 2011, EnergySolutions and Studsvik partnered to process resins, Semprasafe, which significantly increased the Type B cask transport. In early 2012, when WCS facility opened accepting Class A, B and C LLRW, demand for Type B LLRW transport casks increased

tremendously. In addition, National Nuclear Safety Administration (NNSA) initiated a mission to remove excess, unwanted, abandoned, or orphan radioactive sealed sources that pose a potential risk to health, safety, and national security.

In response to the Type B cask shortage crisis, EnergySolutions added to its fleet two (2) additional 8-120B casks formerly owned by Studsvik and started fabrication of additional casks (8-120B and 3-60B) essentially tripling their Type B LLRW transport cask fleet. Since the opening of the WCS facility, Robatel Technologies USA, division of the Robatel group (France) entered to the US market with its RT-100 Type B LLRW transport cask licensed by the US NRC. Recently, it was announced that other casks design firms/manufacturers (Areva, Holtec International and WMG) are in the process of licensing of their own Type B LLRW transport cask designs, as well.

BACKGROUND

This section will discuss several factors which resulted in decreased and subsequent increased the demand for Type B LLRW transport casks over last several years.

1. Factors which decreased demand for Type B transport casks:

a) Closure of Barnwell facility for generators of LLW in 34 US states:

Opened in 1971, The Barnwell Waste Management Facility (BWMF) Operated by Chem-Nuclear Systems, a subsidiary of EnergySolutions, accepted all classes of LLRW (Type A, B and C). Following July 1, 2008, BWMF could only accept LLRW from state members of the Atlantic Compact (SC, CT, NJ) which left a majority of the US states without any ability to have access to disposal of Class B and C LLRW. For many years, the BWMF had been the only LLRW disposal facility accepting Class B and C waste from LLRW generators throughout the country, except those that have access to the Northwest Compact Site located at Richland, Washington. Many Class B and C waste generators considered interim/permanent storage of LLRW Class B and C on site. Due to this event demand for bulk Type B packages had markedly decreased.

2. Factors which increased demand for Type B transport casks:

a) NRC Approval of Blended Resins and Processed Filters

Although thought to be unacceptable for decades, EnergySolutions, EPRI, and others lobbied for NRC agreement that resin blending was acceptable in accordance with 10 CFR 61 and the associated Branch Technical Position (BTP) papers. Following NRC's confirmation that resin blending did not violate their regulations or intent as long as the final blended material was homogeneous, EnergySolutions and Studsvik formed a partnership to blend resins such that the majority of the blended resins could be shipped as Class A LLRW to the Clive Disposal Facility. This NRC confirmation also resulted in the processing of filters by both WMG and EnergySolutions by shredding and homogeneously grouting with cement.

b) Opening of a new Low Level Waste (LLW) Disposal facility (Andrews County, TX) for Class A, B and C LLW

In spring 2012, the Texas Compact Waste Facility (CWF) operated by Waste Control Specialists opened. The WCS facility in western Andrews County is licensed to dispose of Class A, B and C LLRW. The member states of the Texas Compact Commission are Texas and Vermont. The CWF is also available to the other 34 US states that do not have access to a compact disposal facility, if an import permit is applied for by the generator and issued by the State of Texas. Essentially, many generators of LLRW were provided opportunity to ship LLRW to WCS in lieu of storing Class B and C waste in their interim facilities storage. This factor led to sudden increase in demand for Type B LLRW transportation casks.

As of beginning of 2015, there are four disposal facilities in the US that can accept LLW:

- Barnwell, S.C. Barnwell is licensed by South Carolina to receive Classes A, B and C waste. The facility accepts waste from Connecticut, New Jersey and South Carolina.
- Richland, Wash. The facility is licensed by the state of Washington to receive Classes A, B and C waste. It accepts waste from states that belong to the Northwest Compact (Washington, Alaska, Hawaii, Idaho, Montana, Oregon and Wyoming) and the Rocky Mountain Compact (Colorado, Nevada and New Mexico).
- Clive, Utah. Clive is licensed by the state of Utah to accept Class A waste only. The facility accepts waste from all states and regions of the United States.
- Andrews County, Texas. Licensed by the Texas Commission on Environmental Quality and operated by WCS. It accepts Classes A, B and C low-level radioactive waste from Texas, Vermont, and, if an import permit is issued, the 34 states that do not have operating compact facilities, and the federal government.

c) Retirement of vast majority of previously certified Type B transport casks.

On October 1, 2008, a vast majority of previously certified Type B transport casks such as 3-55B, 3-82B, FSV-1, 1-13C, 1-13G and 10-142-B were retired because their CoC's had expired and could not be renewed again.

d) Lack of development of new Type B packages

The process for developing, testing, certifying, and manufacturing of a Type B shipping container can take a number of years, and can cost millions of the dollars or more. Around 2004, US regulations concerning Type B package design and test standards were made mandatory for all packages transported within the US to be consistent with the 1996 revision of the IAEA transport regulations. These changes and the fact that a very small number of new packages have been developed resulted in a shortage of Type B containers for the transport of low (resin, filters) and high activity (irradiated hardware) payloads.

e) Upgrade of certified Type B casks to comply with newer international requirements.

Based on the latest regulatory requirement for existing Type B packages to meet 10 CFR71 requirements; in order to comply with international regulations (1996 edition of IAEA TS-R-01[1]) needed to extend the licensing life of casks in use; and, to allow the fabrication of new

packages of the same design, the process for upgrading all Type B casks to designation “-96” had to be completed. Due to such upgrade constraints, some of the components of the casks in service had to be redesigned.

f) Lessons learned based from prior incidents with Type B LLRW packages

Because of a previous incident with a Type B cask where the radioactive content shifted inside the cask cavity resulted in the allowable dose limits (Studsvik Ir-192 transport incident [2]) to be exceeded, payload contents for some of legacy casks in service was adversely affected. Historically, pre-shipment radiological measurements dictated the payload limit, however under the new rules bounding activity analyses of all specific radionuclide contents have to be made. Shipments with high radionuclide content that previously had been made safely and compliantly can no longer be shipped. These restrictions put an additional burden on the shrinking availability of the Type B transport casks and require more casks to transport the same payload.

g) LLW generation from decommissioning of nuclear reactors

The volume of LLW resulting from decommissioning nuclear power plants varies greatly depending on the type and size of the plant, the length of time it is operated, the decommissioning options chosen, and the waste treatment and volume reduction procedures and methods used. The estimated volume of LLW from the decommissioning of a nuclear power plant ranges from about 100,000 to 400,000 cubic feet [3]. With many nuclear power plants going into decommissioning, demand for Type B LLRW transport casks will only increase over the coming years.

h) The Off-Site Source Recovery Project (OSRP)

OSRP is the US National Nuclear Security Administration (NNSA) sponsored mission to remove excess, unwanted, abandoned, or orphan radioactive sealed sources that pose a potential risk to health, safety, and national security [4]. The initial scope of the project included any sealed sources comprising of Greater than Class C (GTCC) LLRW, however, after September 11, 2001, the mission expanded from environmental concerns to address broader public safety and national security requirements. Currently, there are no licensed and built Type B LLRW transport packages that can safely transport all OSRP sources. To support OSRP, NNSA (via subcontractors) are designing, certifying, and will be manufacturing two new Type B containers for their own use (435B and 380B). Once these new containers are certified, NNSA intends to make the certified designs available to the industry.

OVERVIEW OF THE US CERTIFIED TYPE B CASKS IN SERVICE:

This section provides high level description; technical parameters and allowed content of the US certified Type B casks in service:

EnergySolutions 8-120B [5]		
1	Number of casks in fleet	8
2	Lead shielding equivalence	114 mm (4.5 in)
3	Internal dimensions	Ø 1575 mm x 1905 mm (Ø 62 in x 75 in)
4	Certification	Type B (USA/9168/B(U)-96) NRC and DOE certified packages.
5	Maximum Payload	6,403 kg (14,150 lbs)
6	Secondary container	Eight 55-gallon (200L) drums or 130 ft ³ liner.
7	Approximate Empty Weight	27,080 kg (59,850 lbs)
8	Allowable Content	Byproduct, source, or special nuclear material in the form of dewatered resins, solids, including powdered or dispersible solids, or solidified material, contained within secondary containers; or radioactive material in the form of activated metals, or metal oxides in solid form, contained within secondary container.
EnergySolutions 10-160B [6]		
1	Number of casks in fleet	1 (Commercial) + 4 (Navy) +1 (DOE) + 2 (OPG)
2	Lead shielding equivalence	87 mm (3.43 in)
3	Internal dimensions	Ø 1721 mm x 1949.5 mm (Ø 67.75 in x 76.75 in)
4	Certification	Type B (USA/9204/B(U)-96) NRC and DOE certified packages.
5	Maximum Payload	6,448 kg (14,250 lbs)
6	Secondary container	Ten 55-gallon drums (200L) or 161 ft ³ liner.
7	Approximate Empty Weight	26,131 kg (57,750 lbs)
8	Allowable Content	Byproduct, source, and special nuclear material, non-fissile or fissile-excepted, as special form, or non-special form in the form of process solids or resins, either dewatered, solid, or solidified waste, in secondary containers; or Dewatered, solid or solidified transuranic-containing wastes (TRU), fissile or non-fissile or fissile-excepted, in secondary containers; or Plutonium 239 (Pu-239) as Pu-Be neutron sources meeting the requirements of special form sources; or Neutron activated metals or metal oxides in solid form in secondary containers; or Miscellaneous radioactive solid waste materials, including special form materials and powdered solids, in secondary containers. (vi) Byproduct material as Co-60 loaded using a special shield inserts.



Robatel Technologies RT-100 [7]		
1	Number of casks	4 (3-WCS and 1-Exelon)
2	Lead shielding equivalence	132 mm (5.2 in)
3	Internal dimensions	Ø 1730 mm x 1956 mm (Ø 68.125 in x 77 in)
4	Certification	Type B (USA/9335/B(U)-96) NRC certified package.
5	Maximum Payload	approx. 6787 kg (15,000 lbs)
6	Secondary container	Ten 55-gallon drums or 160 ft ³ liner.
7	Approx. Empty Weight	34,697 kg (76,680 lbs)
8	Allowable Content	Dispersible solids, in the form of dewatered resin and filters contained within secondary containers
EnergySolutions 3-60B [8]		
1	Number of casks in fleet	1 (In fabrication). Expected to be in service late in Spring 2015
2	Lead shielding equivalence	177.8 mm (7in)
3	Internal dimensions	Ø 889 mm x 2778 mm (Ø 35 in x 109.375in)
4	Certification	Type B (USA/9321/B(U)-96).
5	Maximum Payload	4,300 kg (9,500 lbs)
6	Secondary container	Closed Liner
7	Approx. Empty Weight	31,900 kg (70,500 lbs)
8	Allowable Content	Byproduct, source and special nuclear material in the form of inorganic solids, inorganic solidified material, and inorganic resins. Radioactive material in the form of activated and/or contaminated non fuel bearing reactor or accelerator components or segments of components
AREVA TN-RAM cask [9]		
1	Number of casks in fleet	2 (1 in service +1 expected to be in service by end of 2014)
2	Lead shielding equivalence	177.8 mm (7 in)
3	Internal dimensions	Ø 889 mm x 2819.4 mm (Ø 35 in x 111 in)
4	Certification	Type B (USA/9233/B(U)-96).
5	Maximum Payload	4,300 kg (9,500 lbs)
6	Secondary container	Closed Liner
7	Approx. Empty Weight	31,900 kg (70,500 lbs)
8	Allowable Content	Dry irradiated and contaminated non-fuel-bearing solid materials contained within a secondary container

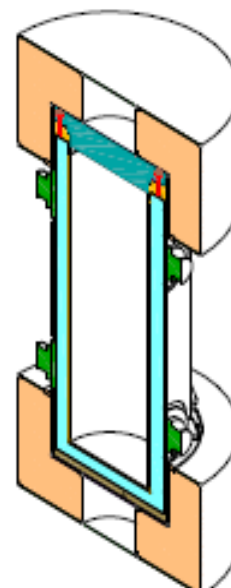

GE-HITACHI GE 2000 [10]		
1	Number of casks in fleet	2
2	Lead shielding equivalence	127 mm(5 in)
3	Internal dimensions	Ø 673 mm x 119 mm (Ø 26.5 in x 54 in)
4	Certification	Type B (USA/9228/B(U)-96).
5	Maximum Payload	2,466 kg (5,450 lbs)
6	Secondary container	Closed Liner
7	Approximate Gross Weight	15,218 kg (33,550 lbs)
8	Allowable Content	Reactor waste, including irradiated fuel rods and byproduct, source, or special nuclear materials.
NNSA B 435 [11]		
1	Number of casks in fleet	Projected to be built before 2017
2	Internal dimensions	Ø 1104 mm x 1530 mm (Ø 43.5 in x 60 in)
3	Certification	Type B (USA/9355/B(U)-96).
4	Maximum Payload	1,590 kg (3,514 lbs)
5	Secondary container	Shielded inserts with different configurations to accommodate sources
6	Approx. Full/Empty Weight	4,535 kg (10,022 lbs) / 2,255 kg (4,984 lbs)
7	Allowable Content	Shielded devices with CS-137 or Co-60 radioactive sealed sources.



OVERVIEW OF PRELIMINARY DESIGNS OF TYPE B CASKS TO BE CERTIFIED IN THE US.

This section provides description, preliminary technical parameters and content of Type B casks to be certified by in the US.

WMG 150B [12]		
1	Lead shielding equivalence	117 mm (4.6 in)
2	Internal dimensions	Ø 1676 mm x 1930 mm (Ø 66 in x 76 in)
3	Maximum Payload	7,014 kg (15,500 lbs)
4	Secondary container	Liner
5	Approximate Empty Weight	28,054 kg (62,000 lbs)
6	Allowable Content	Cartridge Filters, Ion Exchange Resins , Irradiated hardware

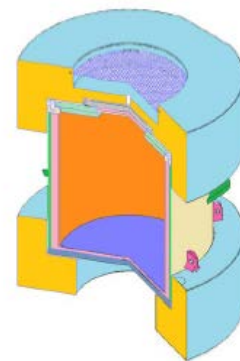

HOLTEC INTERNATIONAL HI-STAR ATB1T Cask for high active waste [13]		
1	Lead shielding equivalence	approx. 267 mm (10.5 in)
2	Dimensions	3740 mm x 2880 mm x 1740 mm (147 in x 113 in x 68 in)
3	Maximum Payload	50,678 kg (112,000 lbs)
4	Secondary container	Liner
5	Approximate Empty Weight	61,538 kg (136,000 lbs)
6	Allowable Content	Generic waste content, including metal waste from nuclear power plant operations and decommissioning (>400KCi of Co-60).
NNSA 380B [14]		
1	Lead shielding equivalence	194 mm (7.625 in)
2	Internal dimensions	Ø 965 mm x 1122 mm (Ø 38 in x 48.125 in)
3	Maximum Payload	5,430 kg (12,000 lbs)
4	Secondary container	Liner
5	Approximate Empty Weight	24,435 kg (54,000 lbs)
6	Allowable Content	Co, Cs, Sr, Ir, Ra, Am, Pu, and Depleted Uranium radioactive sealed sources.

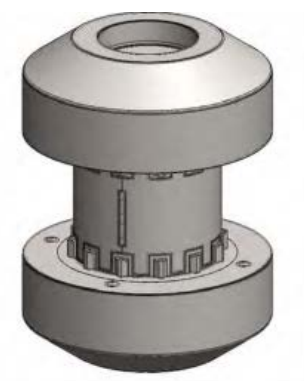
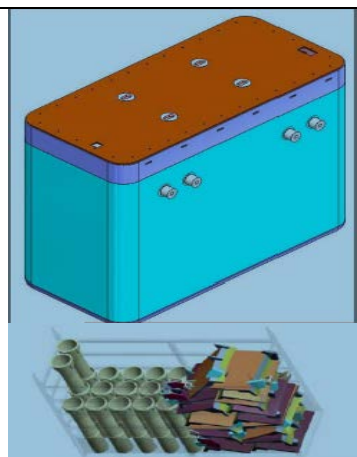

CONCLUSION

Many organizations are in the process of responding to the growing needs for the transportation of radioactive waste and sources by designing new Type B casks. New casks that recently entered into service and new casks designs under development should help to resolve the Type B transportation cask shortage issues in a short term; however, long term planning is required because the cask licensing process can take several years with significant capital expenditures. There are a couple of other potential options available for a long term planning:

- The industry could identify several foreign Type B package designs for Type B shipping with widespread applicability and have these packages certified by the NRC.
- US certificate of competent authority issued by DOT revalidating the international certification of internationally certified shipping containers could be extended (with involvement of NRC) for the domestic use of such casks.
- NNSA could share already licensed designs of Type B casks for sealed sources with the industry.

REFERENCES

1. 'IAEA Safety Standards Series: Regulations for the Safe Transport of Radioactive Material,' 1996 Edition, No. TS-R-1.
2. Richard W. Boyle, Department of Transportation, Washington DC, USA: "Lessons Learned from the Studsvik Ir-192 Transport Incident", presented at U.S. 14th International Symposium on the Packaging and transportation of Radioactive Materials (PATRAM 2004), Berlin, Germany, September 20-24, 2004
3. Dr. Audeen W. Fentiman, P. Andrew Karam, Ronald B. Meyers "Low-Level Radioactive Waste from Decontamination and Decommissioning of Facilities That Use Radioactive Materials", Ohio State University Extension.
4. Off-Site Source Recovery Project, OSRP. Link: <http://osrp.lanl.gov/>
5. EnergySolutions, Public version of Cask Safety Analysis Report Docket Number 71-9168 for 8-120B cask, Consolidated SAR, Rev.7, November 2013.
6. EnergySolutions, Public version of Cask Safety Analysis Report Docket Number 71-9204 for 10-160B cask, Consolidated SAR, Rev.7, November 2013.
7. Robatel Technologies, Public version RT-100 Type B Cask Safety Analysis Report Docket Number 71-9365 TAC Number L24686, Revision 1 , 30 November 2012
8. EnergySolutions, Public version of Cask Safety Analysis Report Docket Number 71-9321 for 3-60B cask, Rev.3, July 2010.
9. Areva TN, RAM Cask Plus brochure # ANP:U-463-V1-14-ENG, 2014
10. Model GE 2000 Transport package brochure by DOE, Oak Ridge National Laboratory, 03/1999.
11. AREVA , 435B Package Safety Analysis Report Docket Bo. 71-9355, Rev.0, March 2013.
12. WMG 150B Cask Shielding/Containment performance discussion presentation to NRC on July 22, 2014.
13. Holtec International Technical Bulletin, HI-STAR ATB1T Type B cask for high active waste, 12/2014.
14. LANS 380-B Type B Shielded Package for Sources presented by AREVA Federal Services LLC on 05/08/2013.