

## **Managing TRU Waste Processing and Storage Issues/Challenges – 15487**

Laura Wilkerson, DOE Oak Ridge Environmental Management (OREM), Frederick Hecker, Wastren Advantage Inc., and Ronald Gentry, Wastren Advantage Inc.

### **ABSTRACT**

Operational events at the Waste Isolation Pilot Plant (WIPP) facility resulted in suspension of disposal operations and waste shipments to WIPP creating significant challenges for the Department of Energy (DOE) complex. The Oak Ridge Transuranic (TRU) Waste Program which was poised to re-start shipping after a 2.5 year suspension of the Carlsbad Field Office (CBFO) certification activities which resulted in on-site accumulation of the highest activity contact handled (CH) TRU waste containers. As a result, Transuranic Waste Processing Center (TWPC) is nearing its physical storage capacity for CH waste and has already reached storage capacity limits for remote handled (RH) TRU waste. The TWPC storage capacity for RH-TRU waste is very limited and dependent on real time shipping support to continue RH waste processing activities in the facilities Hot Cell. Additionally, changes in dispersion modeling (i.e., dry deposition factor changes) used in the TWPC Documented Safety Analysis (DSA) present Material at Risk (MAR) management challenges to effectively manage off-site dose consequences. These facts necessitated the identification of alternative waste storage options for both CH and RH waste to continue waste processing operations at TWPC.

### **INTRODUCTION**

Immediately following the events at WIPP, evaluations were conducted based on 1, 2 and 3year WIPP suspension scenarios to address key factors that will be described in this paper thus providing a basis for the preferred option that would provide the most efficient utilization of resources to continue progress against regulatory (Site Treatment Plan, STP) waste processing commitments. It should be noted that because WIPP was in the initial investigative phase for the second of two operational events that drove the shipment suspension, the duration of the suspension has not yet been determined and therefore multiple options were evaluated including strategies for both short term and potential long term suspension of shipments. As more information became available, the scenarios evaluated at TWPC were revised and the Oak Ridge planning assumptions were continuously revisited and modified.

### **METHODS**

Several key factors were considered in the evaluation phase to ensure that the safest, most productive, and cost effective approach would be selected. The key factors included in the evaluation of the options included:

- Minimization of Regulatory impacts
- Impacts to TWPC operations with focus on continued progress against regulatory commitments
- Resolution of storage capacity issues
- Funding constraints in Fiscal Year (FY) 14-16 and options for FY17 and beyond
- Effects of implementing dispersion modeling changes at TWPC concurrent to the shipping suspension
- Minimization of lifecycle cost growth

Table I, Evaluation Basis Summary of Planned Actions and Key Factors, provides a summary of the key factors included in the analysis of options for continued operations. The Oak Ridge team evaluated multiple options with emphasis on these key factors and has selected the safest, most efficient and

economical solution that maximizes the ability to continue progress in achieving processing goals while minimizing overall Site Treatment Plan impacts.

## **DISCUSSION**

### **Minimization of Regulatory impacts**

Regulatory commitments were considered a high priority factor that drove the evaluation of actions that could be taken to meet existing STP milestones. The existing Oak Ridge STP milestones are structured on completion of CH and RH “waste processing” and CH and RH TRU waste “certification.” Since the STP milestones do not involve “shipping” commitments, the critical focus of any option to meet the current STP milestones required solving the issue of extended storage of the CH-TRU waste inventory with difficult challenges for extended storage of RH-TRU waste.

It was concluded that although significant progress could be accomplished toward the completion of existing CH and RH processing/certification milestones, and the extended storage issue could be resolved, all milestones except CH certification would need to be renegotiated due to the WIPP suspension impact on STP completion dates (including loss of contingency). However, this option assumed that Central Characterization Project (CCP) resources would remain at the TWPC to perform certification activities on the schedule required to meet the milestones regardless of the shipment suspension. To date, DOE has committed to retain the CCP resources. Also, it should be noted that re-certification of CCP by Environmental Protection Agency and the State of Nevada to resume certification activities at the TWPC during this same period was still pending which added to the risk of committing to a single option. Shortly thereafter CCP did complete re-certification for both CH and RH waste. Early on it was determined that a 2 year suspension of WIPP operations would not impact STP milestones further since there were no shipping milestones in the STP. WIPP delays extending to three years and beyond did present issues with continued storage, project contact requirements and ultimately additional project operating costs beyond the projected life-cycle baseline.

Another factor that potentially would impact the CH-TRU processing completion milestone due to the suspension of shipments was related to processing of a specific set of waste containers identified in the Solid Waste Storage Area (SWSA) 5 processing plan. Specific controls were in place that required shipment of a subset of processed SWSA 5 CH-TRU waste materials prior to performing retrieval and processing operations of other containers. This restriction was defined in ORNLs security plan and established to ensure compliance with nuclear material inventory limits that constrain movements of and avoid roll-up of fissile quantities that would exceed required controls specified in the applicable Vulnerability Assessment (VA).

-TRU processing STP milestone.

The RH Processing STP milestone was also impacted because of the time required to design, construct, procure and deploy a new RH-TRU waste storage capability. The WIPP shipping suspension directly resulted in scheduled processing delays for high dose rate RH cask processing in the Hot Cell. The CH-TRU Certification and the RH-TRU Certification milestones are being revised as a direct impact of the WIPP shutdown.

The WIPP events and resulting impacts to the STP milestones meet the basis for extension or renegotiation under the STP as “good cause” and it is expected the milestones will be revised.

### **TRU Waste Storage Capacity/Effects of Dispersion Modeling Changes/Funding Constraints**

On-site and off-site options were considered to solve the extended storage issue for both CH and RH-TRU waste. The extended storage requirement is exacerbated by the 2.5 year suspension of TRU waste

certification and shipping which resulted in accumulation of the highest activity CH-TRU waste containers at TWPC. This large backlog of CH-TRU to ship has resulted in the TWPC nearing physical and radiological Material at Risk (MAR) storage capacity. Additionally, the TWPC storage capacity for RH-TRU waste is very limited and dependent on real time shipping support to continue RH Hot Cell operations. The TWPC storage capacity for RH-TRU canisters is nominally 14, driving the current investment to create additional RH-TRU canister storage capability.

Implementation of new dispersion modeling criteria at TWPC and the anticipated DSA changes (coupled with the WIPP shutdown) resulted in the need to relocate radiological MAR from TWPC to the Oak Ridge National Lab (ORNL) legacy storage facilities.

The team quickly confirmed that the existing legacy TRU waste storage areas at ORNL had both physical capacity as well as radiological MAR capacity that could accommodate all of the CH-TRU and RH-TRU waste containers projected for return based on TWPC capacity constraints.

The key challenge to extended storage was capacity for RH-TRU waste. The team evaluated development of storage capacity on the Oak Ridge Reservation with focus at ORNL, as well as potential off-site options including a commercial option at Waste Control Specialist (WCS) and a government option at Savannah River Site (SRS). All options would require a new investment in protective features for storage assumed to be concrete over-packs that would provide dose shielding as well as provide design features that could be credited in a DSA. Similar to TWPC, SRS currently has a limited (~16 canister) storage capacity, additionally; state equity issues likely preclude consideration of that option. The WCS, located near Andrews, Texas, option was unlikely due to DOE Headquarters strategic utilization of WCS capacity to support Los Alamos National Lab (LANL). Additionally, acceptance under the license at WCS would need to be confirmed and ultimately high storage costs for extended shutdown at WIPP eliminated this option.

It was concluded that in the 1 year suspension scenario deployment of RH-TRU waste storage capacity would not be considered since the RH milestone would need to be extended due to the immediate lack of RH-TRU shipping support and RH-TRU storage capacity. These facts drove STP end point extension for processing high dose casks in the hot cell. However, the team believed continued WIPP suspension beyond 1 year would merit consideration of deployment of RH canister storage capacity to allow for completion of processing and certification, to take advantage of the already existing trained and experience workforce, and to avoid significant lifecycle cost increases due to extended project completion schedules should the suspension extend for several years. Deployment of RH storage capacity would be planned “just in time” to allow for optimum capital cost control should the WIPP suspension timeframe be less than assumed.

Concrete overpacks for loaded RH-TRU canisters would be planned for deployment one quarter in advance of processing allowing for optimum deployment based on continued information about WIPP resumption of operations. Funding to support extended storage including RH-TRU capacity would be required near term (2015) under the 2 year suspension scenario.

It is anticipated that the risks associated with extended storage of CH and RH-TRU waste will be low during the 1 and 2 year suspension scenarios. Some CH-TRU containers have been stored in excess of 2 years during the previous suspension of CBFO certification activities, many of these containers have been through the certification process since CCP return and have passed Non Destructive Examination (NDE) certification. Limited concerns existed for accumulation of condensed liquids due to humid air exchange during thermal cycles of vented containers, which was confirmed to not be a problem based on certification results to date. RH-TRU canister gasket degradation was evaluated as a potential key risk. It

was determined that the gasket shelf life is certified by the manufacturer at 3 years, not impacting container integrity during extended storage if installed within the shelf life period.

A WIPP suspension scenario of 2 years or longer involves deployment of RH-TRU storage capacity using a Removable Lid Canister (RLC) Overpack (ROP). Loaded RLCs (72-B Canisters) of RH-TRU waste will be loaded into the ROP. The over packed RLC is then transferred to UCOR URS | CH2M Oak Ridge LLC (UCOR) in the ROP as necessary for temporary storage until shipment schedules supports return to TWPC. A small staging area is being evaluated to provide some lag storage capability to allow scheduling and performance of loadouts from the Process Building to the ROP and aid in coordination of transfers to UCOR. The ORNL storage areas retained the original safety basis and RCRA permits which allows return transfer of the RH-TRU waste.

The movement of the ROP to UCOR is not required to meet the site Transportation DSA requirements. Both the ORNL Mega-DSA and the TWPC DSA will be revised to include the new operational activity following completion of applicable hazard analysis. The ROP is not required to be licensed under NRC criteria.

**Table I, Evaluation Basis Summary of Planned Actions and Key Factors**

<i>Planned Actions:</i>		
<b>Continue full scale processing of CH and low dose RH waste, delay the processing of high dose RH hot cell waste until WIPP resumption or on-site RH waste storage capacity can be deployed, and utilize ORNL legacy TRU waste storage areas for CH waste</b>		
<i>Key Factors</i>	<i>Up to 1 Year Suspension</i>	<i>Up to 2 Year Suspension</i>
Regulatory Commitments	<ul style="list-style-type: none"> <li>➤ Requires renegotiation of Site Treatment Plan (STP) milestones</li> <li>➤ Estimated 3 month delay for CH processing completion milestone</li> <li>➤ Estimated 1 year delay for RH processing completion milestone</li> <li>➤ No impacts to CH certification milestones (assumes CBFO commitment through FY17)</li> <li>➤ Estimated 3 month delay for RH certification milestones</li> <li>➤ Solid position for STP renegotiation as “Good Cause”</li> </ul>	<ul style="list-style-type: none"> <li>➤ No additional STP impacts beyond 1 year suspension due to lack of shipping milestones under the STP</li> </ul>
Continued Operations	<ul style="list-style-type: none"> <li>➤ Allows continued full scale processing of CH waste (including SWSA 5) and low dose RH casks</li> <li>➤ High dose RH casks deferred 1 year</li> </ul>	<ul style="list-style-type: none"> <li>➤ Extends TRU waste shipping campaign through FY18</li> </ul>
Funding / Lifecycle Cost	<ul style="list-style-type: none"> <li>➤ Includes a solution for extended storage of CH waste in ORNL legacy facilities</li> <li>➤ Addresses new dispersion modeling criteria at TWPC</li> <li>➤ SWSA 5 extended material storage issue resolved allowing for processing</li> </ul>	<ul style="list-style-type: none"> <li>➤ Includes a solution for extended storage of RH canisters at TWPC to allow the processing of high dose casks requiring FY15 funding commitment and final decision by October 1, 2014.</li> </ul>
Funding / Lifecycle Cost (cont'd)	<ul style="list-style-type: none"> <li>➤ Requires additional FY14 funding to support UCOR CH Storage Return/SWSA 5 storage solution</li> <li>➤ Early CPE finish savings – ~\$1.06M EUR (\$1.3M USD)</li> <li>➤ Requires additional FY17 funding for RH recovery processing, accelerated shipping support at TWPC, extended storage and handling at UCOR</li> <li>➤ FY14~\$0.49M EUR (\$0.6M USD); FY15~\$0.16M EUR (\$0.2M USD); FY16~\$0M EUR (\$0M USD); FY17~\$7.82M EUR (\$9.6M USD)</li> <li>➤ Total funding need ~\$7.33M EUR (\$9.0M USD)</li> </ul>	<ul style="list-style-type: none"> <li>➤ Requires additional FY14 funding to support UCOR CH Storage Return/SWSA 5 storage solution</li> <li>➤ Early CPE finish savings – ~\$1.06M EUR (\$1.3M USD)</li> <li>➤ Requires additional FY17 funding for extended RH processing, accelerated shipping at TWPC and extended storage and handling at UCOR</li> <li>➤ Requires additional FY18 funding to complete TWPC/UCOR/CBFO material handling and shipping campaign</li> <li>➤ FY14~\$0.41M EUR (\$0.5M USD); FY15~\$2.44M EUR (\$3.0M USD); FY16~\$0.49M EUR (\$0.6M USD) FY17~\$9.77M EUR (\$12.0M USD)</li> <li>➤ Total funding need ~\$43.1M EUR (\$53M USD)</li> </ul>
Project Schedule	<ul style="list-style-type: none"> <li>➤ Early Cask Processing Enclosure finish in FY17</li> <li>➤ Maintains CBFO Certification and</li> </ul>	<ul style="list-style-type: none"> <li>➤ Extends TWPC/UCOR/CBFO material handling and shipping campaign through</li> </ul>

<i>Planned Actions:</i>		
<b>Continue full scale processing of CH and low dose RH waste, delay the processing of high dose RH hot cell waste until WIPP resumption or on-site RH waste storage capacity can be deployed, and utilize ORNL legacy TRU waste storage areas for CH waste</b>		
<i>Key Factors</i>	<i>Up to 1 Year Suspension</i>	<i>Up to 2 Year Suspension</i>
	Shipping completion in FY17 ➤ Extends RH processing through FY17	FY18
<i>Risks</i>	➤ Tennessee Department of Environment and Conservation (TDEC) approval of STP revision – Low ➤ WIPP Waste Acceptance Criteria changes – Low ➤ Funding (FY15) – Moderate to High ➤ Container degradation/rework: ○ CH – Very Low	➤ WIPP WAC changes – Low ➤ Funding (FY17-18) – Low to Moderate ➤ Container degradation/rework: ○ CH – Very Low  ○ RH – Low

**Description of ROP**

The overpack chosen for the RH-TRU waste is the Concrete Removable Lid Canister (RLC) Overpacks (ROPs). Loaded RLCs (72-B Canisters) of RH waste will be loaded into the ROP. The overpacked RLC is then transferred to UCOR as necessary for temporary storage until shipment schedules supports return to TWPC. A small staging area may be established at TWPC to allow some lag storage capability to allow scheduling and performance of loadouts from the Process Building to the ROP and coordination of transfers to UCOR.

The general design features of the ROP are shown in Figure 1, Single RLC, ROP Preliminary Design Concept.

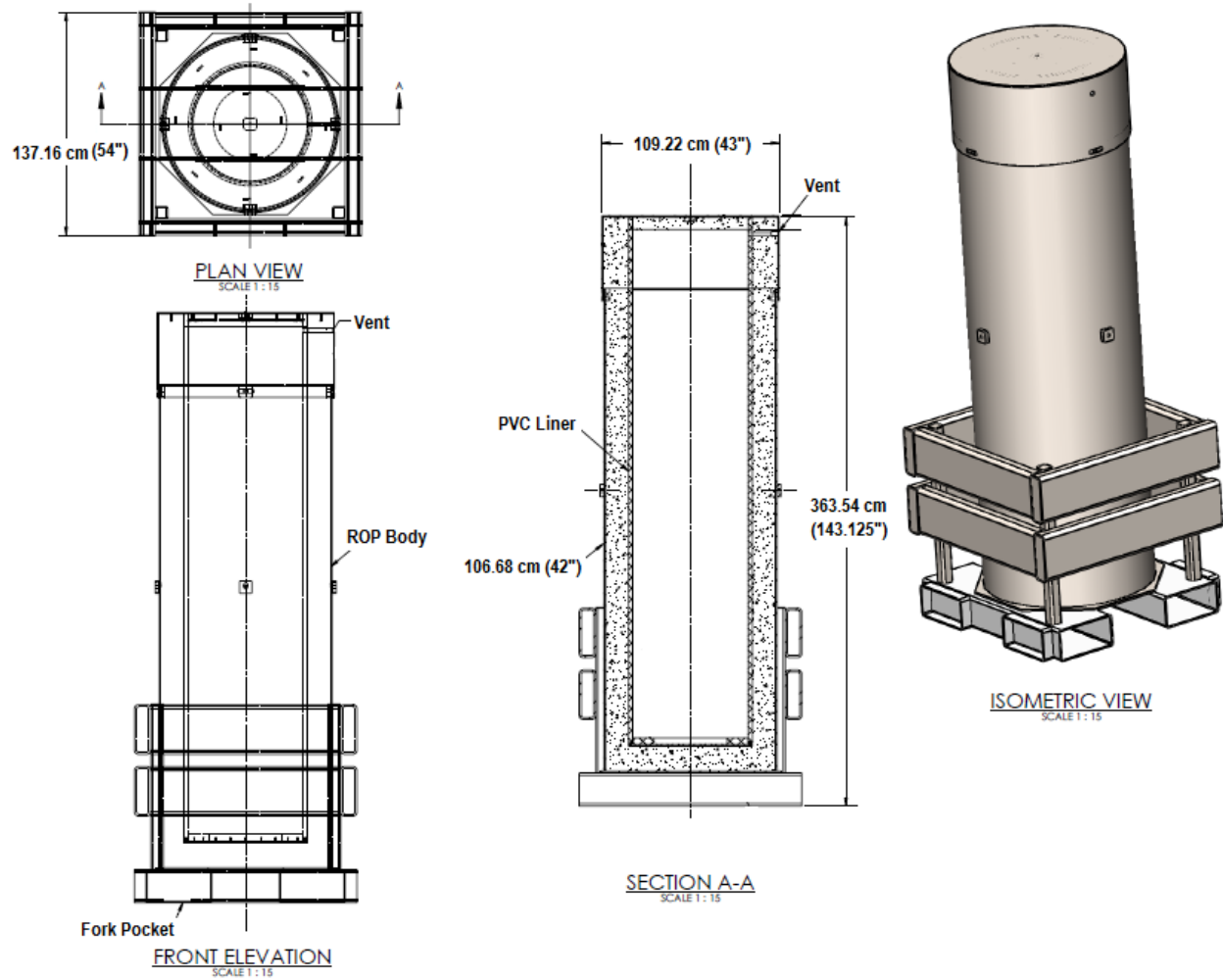

**Fig 1, Single RLC, ROP Preliminary Design Concept**

Each ROP will hold a single RLC (i.e., 72-B Canister) that is nominally 64.8 cm (25.50”) O.D. x 304.8 cm (120”) long. The RLC design specifications are provided in U.S. DOE Washington TRU Solutions, LLC, Drawing, 165-F-007-WI, RH TRU 72-B Cask Removable Lid Canister Assembly [1].

While a ROP design which would hold two RLCs was initially planned, several factors (e.g., consideration of gross weight and handling/transportation difficulties) shifted the preferred option to the single RLC storage design. The ROP is to be designed for a single RLC; maximum RLC payload is 1,364 kg (3,000 lbs.).

- RLC Tare Weight: 517.1 kg (1,140 lbs.), nominal
- RLC Max Gross Weight: 1,923 kg (4,240 lbs.)

A cursory examination indicated that a square shield pallet for a single RLC will be stable under national consensus code seismic criteria (e.g., IBC). During detail design the concept of a “naked” concrete base proved problematic and an integral steel pallet and outer steel wall was incorporated into the component, forming the bottom of the precast concrete. Total estimated gross weight should easily be <133.4 kilonewton (30 kips). The existing nominal fork lift capacity is 160.1 kilonewton (36 kips), which will be reduced when handling shield pallets closer to the fork tips.

General ROP design considerations included:

- 1 All precast concrete construction shall be in accordance with Precast Concrete Institute standards.
- 2 Minimum thickness on vertical sides is 15.24 cm (6”) of concrete.
- 3 Lid lifting devices incorporated.
- 4 Method to secure lid shall be provided (use lift point)
- 5 Loaded ROP shall be designed for movement by forklift w/forks at locations shown. Lift points may be added as design is finalized.
- 6 Internal lining required on bottom and sides to prevent physical damage to external surface of RLC.
- 7 The ROP shall meet the ALARA design criteria.
- 8 ROP shall provide impact resistance during postulated vehicle impact scenarios to reduce impacts of postulated 2-hour fuel fire.
- 9 Forklift pockets are sized to support UCOR forklift equipment, i.e., 31.75 cm x 15.24 cm (12.5” x 6”)

The ROP is also required to be constructed of fire resistant concrete equivalent to walls, floors and roofs as discussed in the American Concrete Institute’s Standard 216.1-07 [2]. Table 2.1 (e.g., to attain a 2 hour fire resistance rating the concrete must be at least 5 inches thick).

### **SS SSC Designation for ROP**

This component or attributes of the ROP may be designated as a Safety Significant (SS) System, Structure or Component (SSC); the credited features are related to the following design characteristics.

#### **Seismic Criteria**

Overpack shall be stable in the vertical configuration during a seismic event based on national consensus standards (e.g., International Building Code) design criteria for the Oak Ridge area. Overpack shall include provisions for a restraint system if determined necessary during detail design.

#### **Impact Criteria**

ROP shall not catastrophically fail after the following impacts when the ROP is positioned against a full-height immovable object, similar to a retaining wall. Impact of a 36,360 kg (80,000 lb.) truck traveling at 24.14 kph (15 mph); impact is at “bumper” height. Impact of a single fork tine of a large fork truck traveling at 24.14 kph (15 mph); impact is at the vertical centerline of the ROP body. Impact area due to the fork tine impact is nominally 2.54 cm (1”) x 30.48 cm (12”) (H x W).

Catastrophically fail is defined as a crack of sufficient magnitude that allows sufficient fuel to contact the container during a three minute fire. Incidental cracking is acceptable.

#### **Fire Resistance Criteria**



Fire resistance, e.g., 2-hour fire resistance in accordance with minimum equivalent thickness for fire resistance rating, using Tables 2.1 and 2.3 of ACI Standard 216.1, Chapter 1, which describe the acceptable methods for determining the fire resistance of concrete and masonry assemblies and structural elements including walls, floor and roof and roof slabs, beams, columns, lintels, and masonry fire protection for structural steel columns. These methods are used for the design and analytical purposes and are based upon the fire exposure and applicable end-point criteria of ASTM E119 [3].

ROP shall exhibit 2-hour fire resistance in accordance with minimum equivalent thickness for fire resistance rating, using Tables 2.1 and 2.3 of ACI Standard 216.1.

Radiological shielding characteristics or properties, e.g., 6-inch thick concrete with a defined minimum density to provide the required dose rate reduction. The ROP manufacturer shall be certified by the National Precast Concrete Association (NPCA) and the ROP shall be provided in accordance with approved manufacturer's Quality Control Program.

There are costs associated with design, construction, and implementation of the ROP for storage. Preliminary round order of magnitude cost estimates for extended storage RH capacity is approximately \$3.74M Euro (\$4.6M) in the 2 year scenario (126 canisters), and approximately \$5.05M Euro (\$6.2M) for the RH-TRU processing lifecycle (nominally 250 canisters).

#### **Minimization of Lifecycle Cost Growth**

Optimization of available trained resources to continue to make progress processing and certifying the TRU waste in Oak Ridge was a critical factor to ensure a shorter completion schedule and minimize lifecycle cost growth. Full utilization of available resources and unit operations was determined to be possible to continue to strive for the best completion schedule for the TRU waste project at Oak Ridge. This can be accomplished by deferral of processing RH high dose hot cell casks until WIPP resumes operations or until RH storage capacity is deployed, and utilization of the hot cell for processing of low dose casks currently planned to be processed in the Cask Processing Enclosure (CPE). Schedule completion optimization for CBFO certification and shipping activities are maintained under the 1 year scenario. Schedule extension and associated lifecycle cost increase would be realized for TWPC, CBFO, and UCOR under the 2 year suspension scenario due to the extension of shipping beyond October, 1 2017.

To reduce cost growth, the use of other DOE facilities for processing technically challenging waste was evaluated. However, the technically challenging wastes contain combustible gas hazards that make transport over public roads unallowable. TWPC waste is extremely unique and may not comply with processing capabilities of other DOE facilities.

#### **Processing Efficiency**

The best strategy moving forward to process RH waste must optimize the most efficient processing, characterization, certification, and shipping approach while dispositioning waste at the lowest waste class that is technically achievable. This approach will be the most efficient, and ensure single pass treatment and eliminates non-compliance with the WAC. While alternative approaches were reviewed, each introduced new issues or constraints.

For example, blending the remaining CH with RH to reduce the RH output volume was reviewed. While conceptually it would seem viable and would allow processing all waste concurrently, the fact that the dose rates in the remaining TRU waste make it impossible to process as one waste stream in the CH process line. Additionally, processing CH in the RH Hot Cell would be cost prohibitive. Additionally,

there is not sufficient CH waste to down-blend the remaining RH waste to CH as most of the CH is already stockpiled and certified.

Compaction was also considered, but compacting RH waste could result in concentrating pyrophoric or lithium hydride hazards (CH) or high neutron dose (RH) in the wastes resulting in a package that does not meet disposal requirements and creates significant, unnecessary hazards

## CONCLUSIONS

Continue full scale processing of CH and low dose RH-TRU waste, delay the processing of high dose RH hot cell waste until WIPP resumption or on-site RH-TRU canister storage capacity in the ROP can be deployed, and utilize ORNL legacy TRU waste storage areas for CH waste.

The preferred option results in:

- Least impact to the STP milestones;
- Continued full scale processing;
- Includes a solution for extended storage of CH/RH TRU waste at TWPC/ORNL;
- Optimal utilization of trained/qualified work force;
- Acceptable near term (current year) cost growth;
- Holds CBFO completion in 2017 in 1 year suspension scenario;
- Provides optimal life cycle cost control; and
- Provides a sound position for renegotiation of the STP milestones with the TDEC.

Based on analysis of the key factors discussed above, the team concluded that significant progress against regulatory commitments can be made through continued full scale processing at TWPC during the WIPP suspension primarily through quick resolution of the CH-TRU storage issue by utilizing ORNL legacy storage facilities. For RH-TRU, the overpacked RLC transferred to UCOR for temporary storage until shipment schedules supports return to TWPC is the best option. This option provides the best opportunity to optimize schedule and lifecycle costs by completing processing and certification as soon as possible awaiting resumption of shipping. Should the suspension exceed 3 years, the project may be required to scale back to a surveillance and maintenance mode awaiting resumption of shipping with all waste processed and certified for disposal.

## REFERENCES

- U.S. DOE Washington TRU Solutions, LLC, Drawing, 165-F-007-WI, RH TRU 72-B Cask Removable Lid Canister Assembly
- American Concrete Institute's Standard 216.1-07, Code Requirements for Determining Fire Resistance of Concrete and Masonry Construction Assemblies (Metric), Joint ACI/TMS Comm 216, 2008
- ASTM E119, Standard Test Methods For Fire Tests of Building Construction And Materials, Revision 14, 10/1/14

## ACKNOWLEDGEMENTS

- Rast, John L (RLQ), ORN-gov [mailto:John.Rast@ettp.doe.gov], Structural Analysis
- Wagner, Gregory, Design Engineering Manager [mail: greg.wagner@truproject.com], TWPC
- Karen Balo, Safety Basis, DOE-OREM