

**Lessons Learned in the Design and Use of IP1 / IP2
Flexible Packaging - 13621**

Mike Sanchez, VP Global Sales, PacTec, Inc.
Wendall Reeves, National Sales Manager, PacTec, Inc.
Bill Smart, Nuclear Sales Director, PacTec, Inc.

INTRODUCTION:

For many years in the USA, Low Level Radioactive Waste (LLW), contaminated soils and construction debris, have been transported, interim stored, and disposed of, using IP1 / IP2 metal containers. The performance of these containers has been more than adequate, with few safety occurrences. The containers are used under the regulatory oversight of the US Department of Transportation (DOT), 49 Code of Federal Regulations (CFR).



B25 Containers transported on flatbed

In the late 90's the introduction of flexible packaging for the transport, storage, and disposal of low level contaminated soils and construction debris was introduced. The development of flexible packaging came out of a need for a more cost effective package, for the large volumes of waste generated by the decommissioning of many of the US Department of Energy (DOE) legacy sites across the US. Flexible packaging had to be designed to handle a wide array of waste streams, including soil, gravel, construction debris, and fine particulate dust migration. The design also had to meet all of the IP1 requirements under 49CFR 173.410, and be robust enough to pass the IP2 testing 49 CFR 173.465 required for many LLW shipments. Tens of thousands of flexible packages have been safely deployed and used across the US nuclear industry as well as for hazardous non-radioactive applications, with no recorded release of radioactive materials. To ensure that flexible packages are designed properly, the manufacturer must use lessons learned over the years, and the tests performed to provide evidence that these packages are suitable for transporting low level radioactive wastes.

FLEXIBLE PACKAGE DESIGN AND FEATURES / IP2 TEST:

Flexible waste packages, like metal containers, are engineered products, fabricated under strict quality controls, and are tested and certified to IP-1 or IP-2 standards, as required by the intended application and user requirements. Drop tests, stacking tests, simulated transport conditions, meteorological changes, and the like are all tests that flexible packages have been subjected to.



Stack test with 54,515 kg of weight



Weighing the package for a drop test

Flexible packages have been tested and certified to IP-1 and IP-2 standards per 49 CFR 173.411; stack test, and drop test. The IP2 test was performed to ensure that “construction debris” was included in the certification.

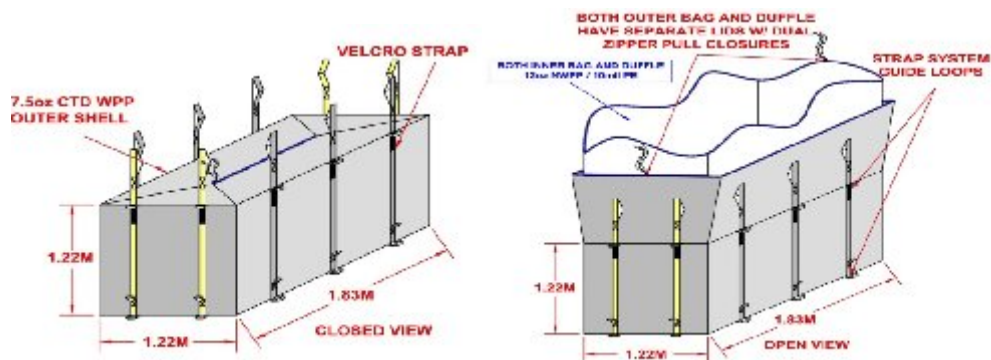

In order to safely contain large, sharp, heavy objects, associated with construction debris, the materials used to fabricate flexible packages are robust, and include woven and non-woven polypropylene, polyethylene, nylon, and other special materials. Bag seams are strongly constructed and are carefully manufactured, and may require double stitching or other methods to ensure strong, tight seams, depending upon applications. Each bag receives quality control inspections throughout the manufacturing process and independent lab tests, as required. Note from the Figures that the lifting straps are held in place in such a way that they are not stitched directly to the bag. This design insures that if there is a shift in the contents of the bag, the straps will not tear away from the bag, causing a breach in the package. Flexible packaging is manufactured in special purpose ISO 9001 2008 facilities.

The flexible waste package is a large rectangular bag, with special closures, including zippers and a unique lifting system. Custom liners can be added to the bag for wet applications, and to contain fine particulate dust. In that each bag is individually fabricated, there are several options available regarding size, volume, closures, lifting devices, internal stiffeners, and so on. Smaller, scaled down bags can be used where space is limited, for example.

TESTING FOR FINE PARTICULATE DUST CONTAINMENT:

Flexible packaging has been tested and certified to IP-1 and IP-2 standards per 49 CFR 173.410, 411, here in the USA, but to meet the International Atomic Energy Agency (IAEA) Safety Standards TS-R-1 Section VI Requirements for Industrial Packaging, additional testing was needed.

PacTec, working with the Low Level Waste Repository (LLWR), UK, carried out some special testing of the flexible package. The test was to confirm the leak tightness of the bag during routine conditions of transport and meteorological conditions in the UK. The test method chosen was to use a vibration table test with associated pressure flow test inside the bag to increase pressure in the bag, with a tracer dust to detect release of any fine particulate dust.

Testing was carried out by Wyle Laboratories in Huntsville, AL USA and incorporated a large vibration table, using military standard test procedures for cargo transportation “MIL-STD-810F”. The flexible package, loaded with sand/soil, gravel and construction debris as well as a Fluorescein tracer dust was placed on the vibration table. To ensure that the test specimen represented the original design, the flexible package containment barrier was not penetrated and a unique method of increasing the air volume was developed using a Co2 gas cylinder placed inside the bag. Establishment of the test parameters for Vibration Profile, Air Pressure/Volume are discussed below..

Vibration Profile

The Vibration test profile was taken from the recognized UK Industry Forum “Transport Container Standardization Committee” TCSC 1006 The Securing/Retention of Radioactive Material Packages on Conveyances” using data collected for road transport under a range of driving conditions for a 20’ Intermodal Container. Figure 14 and Figure 6 are the data recorded from a 20’ intermodal container with a 10 tonne load, measuring instantaneous acceleration. It was decided by LLWR to use load case 3 from Figure 6, to set the vibration parameters on the vibration table.

I. Figure 14 – Acceleration data for 20’ Intermodal Container

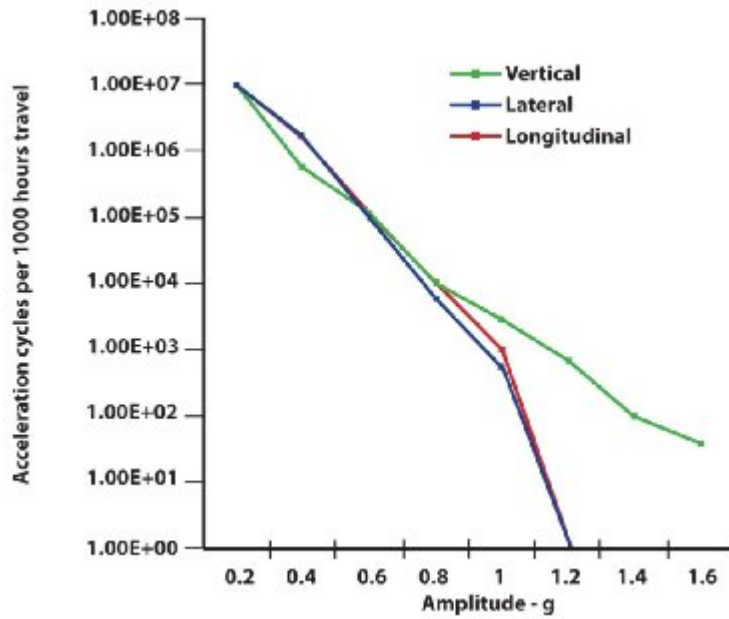

II. Table 6 - The frequency of occurrence of a range of acceleration values – 20' Intermodal container

Load case	Longitudinal amplitude -g	Lateral amplitude -g	Vertical amplitude -g	Total number of cycles per 1000 hours
1	0.4	0.2	0.4	11.15 x 10 ⁶
2	0.8	0.4	0.8	1.93 x 10 ⁶
3	1.2	0.6	1.2	99.5 x 10 ³
4	1.6	0.8	1.6	5.36 x 10 ³
5	2.0	1.0	2.0	491

Pressure/Volume

LLWR utilized Gravatom's experience and data (Gravatom, now ONET, was a technical engineering firm which was involved in the testing of nuclear packaging in the UK) to simulate the effects of extreme ambient weather conditions and pressure changes. To calculate the combined effect of pressure and volume changes to set the test parameters the following "Gravatom developed method" was adopted:

Pressure Changes were calculated by using meteorological data from 1870 to 1970 shows that the highest and lowest mean sea level pressures within the UK rounded to the nearest mbar are 1055 mbar (Aberdeen, January 1902) and 925 mbar (Ochertyre, January 1884).

WM2013 Conference, February 24-28, 2013, Phoenix, Arizona, USA

Using the gas law equation, if the bag is filled at a pressure of 1055 mbar and the pressure falls to 925 mbar during transport, the air volume V_2 is given by:

$$V_2 = V_1 \times \frac{P_1}{P_2} = 0.5 \times \frac{1055}{925} = 0.570 \text{m}^3$$

Increase in air volume = $0.57 - 0.5 = 0.07 \text{m}^3$ (a 14% increase in volume).

Altitude change was calculated by the average decrease of pressure due to increase in height; this is known to be approximately 12mbar per 100m. Considering typical road transport in England the M6 highway at Shap reaches a height of 914 ft (278m) and the M62 highway reaches a height of 1221ft (372m). If maximum height of 400m is considered, the decrease in pressure due to change in altitude is 48mbar.

This is a change of nominally 5% resulting in a 5% increase in air volume from 0.5 to 0.525m^3 , an increase of 0.025m^3 .

Combined Effect

Although extreme low pressures may in theory be experienced during transport, such pressures would result in cold wet conditions and would not coincide with the highest temperatures. It is reasonable to surmise that the highest temperatures would only occur at pressures in excess of 1000 mbar. If filled at the extreme maximum pressure of 1055mbar then transported at a pressure of 1000mbar this is a 5% decrease in pressure which would result in a 5% increase in air volume.

The following combined effects are considered:

Increase in air volume due to 50°C rise in temperature	= 18%
Increase in air volume due to 55mbar fall in pressure	= 5%
Increase in air volume due to 400m change in altitude	= 5%
Total increase in air volume	= 28%

Interpretation of test parameters to satisfy IAEA Safety Standards TS-R-1 Section VI par 615

To increase in the air volume by 28%, it was calculated that 4 ounces of Co2 would need to be released in the bag. Therefore a Co2 canister with a slow release valve set to release the predetermined amount of Co2 was placed within a specially designed box, and then placed inside the flexible inner package to simulate the increased air volume that may occur during routine conditions of transport. For the vibration portion of the test, although a typical flexible package would most likely not travel more than 5-10 hours, the test specimen was tested to failure, simulating over 180 hours of drive (transport) time*. At set intervals during the test, inspections were carried out on the test specimen at 30 minute intervals using a fine mist water spray and a UV light, no dispersal of the contents were detected during the test.

*1 hr. of test time is equivalent to over 180 hrs. of travel time: $X = [(5\text{Hz} \times 3,600 \text{ sec}) / 99,500 \text{ cyc}] \times 1000 \text{ hr.} = 180.9 \text{ hrs.}$



Flexible package used in testing at Wyle Laboratories, Huntsville, AL USA

USING FLEXIBLE WASTE PACKAGES / OPERATING INSTRUCTIONS:

When using flexible packaging, it is imperative to follow the manufacturer's operating instructions. Like any package used for waste containment, not following the instructions can cause a failure of the package, and a breach of the contents, which may cause costly clean up and repackaging of the waste.

The waste packages are usually loaded while positioned inside a loading frame. The lightweight loading frames are easily assembled and moved by two operators, and the standard loading frames may require simple lifting equipment. Unlike metal containers, flexible packages are easily handled and stored when empty and two operators can easily move, stack, and load an empty flexible package.

The training required to enable operators to position, and load, the packages is not extensive, but does require some training. Also, after the package is loaded, and closed, a tamper indication device can be attached to the closure zippers on the bags, for security.



Lightweight or EZ loading frame



Standard loading frame for flexible packages



Closure details of flexible packages Pallet of 30 empty Flexible Packages

Other applications for flexible waste packaging that have been tested and proven in the USA DOE market, are Low Specific Activity (LSA) and Surface Contaminated Objects (SCO) wraps, and demolition debris bags. The demolition debris bags fit large dump trucks and are used to receive, transport and dispose of large quantities of lightly contaminated demolition rubble.



IP-2 Flexible Package



LSA/SCO Wrap



Demolition Debris bag being dumped

DISPOSAL APPLICATION:

Flexible waste packages are able to conform, to some extent, to the space or cavity they are placed in, as in a repository or landfill for final disposal.



Stacked Flexible Packaging at NTS (Nevada Test Site, NV USA)

WM2013 Conference, February 24-28, 2013, Phoenix, Arizona, USA

The materials of construction of flexible packages are resistant to moisture, and do not corrode, as does mild steel. Actual performance data for long-term exposure of flexible packaging materials in repository conditions is not yet available, however polyethylene and polypropylene in similar conditions are known to be extremely robust and long-lived upwards of 500 years.

SAFETY:

Flexible waste packages have been proven to be safe when used for the applications they have been designed, tested, and certified for. Tens of thousands of flexible LLW packages have been safely used in the USA over the last 15 years, and have now been accepted and being used in the UK. In the US, the bags are DOT certified and also IP-1 or IP-2 certified as a Class 7 package. For the strict UK nuclear market, the bags have been subjected to the more stringent IAEA safety standards.

CONCLUSION:

The design and testing of flexible packaging for LLW, VLLW and other hazardous waste streams must be as strict and stringent as the design and testing of metal containers. The design should take into consideration the materials being loaded into the package, and should incorporate the right materials, and manufacturing methods, to provide a quality, safe product. Flexible packaging can be shown to meet the

criteria for safe and fit for purpose packaging, by meeting the US DOT regulations, and the IAEA Standards for IP-1 and IP-2 including leak tightness.

References

IAEA – International Atomic Energy Agency

TS-R-1- “IAEA Safety Standards”

TCSC - 1006 “The Securing/Retention of Radioactive Material Packages on Conveyances”