

## **Unique Chernobyl Cranes for Deconstruction Activities in the New Safe Confinement – 13542**

N. A. (Vijay) Parameswaran<sup>1</sup>, Igor Chorny<sup>2</sup>,  
Dan Kedrowski<sup>1</sup>, Rob Owen<sup>3</sup>, Eric Schmieman<sup>4</sup>

<sup>1</sup>Bechtel Systems and Infrastructure, Inc., <sup>2</sup>Chernobyl NPP-SIP-PMU (Ukraine),  
<sup>3</sup>PaR Systems, Inc., <sup>4</sup>Battelle Memorial Institute

### **Abstract:**

The devastation left behind from the Chernobyl nuclear power plant (ChNPP) Unit 4 accident which occurred on April 26, 1986 presented unparalleled technical challenges to the world engineering and scientific community. One of the largest tasks that are in progress is the design and construction of the New Safe Confinement (NSC). The NSC is an engineered enclosure for the entire object shelter (OS) that includes a suite of process equipment. The process equipment will be used for the dismantling of the destroyed Chernobyl Nuclear Power Plant (ChNPP) Unit. One of the major mechanical handling systems to be installed in the NSC is the Main Cranes System (MCS). The planned decontamination and decommissioning or dismantling (D&D) activities will require the handling of heavily shielded waste disposal casks containing nuclear fuel as well as lifting and transporting extremely large structural elements. These activities, to be performed within the NSC, will require large and sophisticated cranes. The article will focus on the unique design features of the MCS for the D&D activities.

### **Introduction:**

The Chernobyl nuclear power plant (ChNPP) accident that occurred on April 26, 1986 destroyed Unit 4. After the accident situation was stabilized, it became apparent that sequestration of the damaged reactor was necessary to minimize long term radiological impact on personnel and the environment. A temporary containment building, the Object Shelter (OS), was designed and constructed between May and November 1986.

Although some measures have been taken in the past 26 years to stabilize the structure and reduce corrosion, the risk of collapse of the Object Shelter continues to increase over time. Its containment function needs to be performed by a new structure, and the Object Shelter needs to be dismantled in an orderly manner.

The structural elements being dismantled will be large and heavy. Nuclear fuel material and other radioactive waste will be placed in heavy shielded containers. The dismantling activities and handling of heavily shielded waste disposal casks will require large and sophisticated cranes that are the subject of this paper.

In 1997, a group of experts from Ukraine, the United States and the European Union prepared the Shelter Implementation Plan (SIP) for the conversion of the OS into an ecologically safe system. The SIP consists of 22 tasks, the largest of which is the design and construction of a New Safe Confinement (NSC).

**Description of New Safe Confinement:**

The new safe confinement (NSC) is constructed adjacent to the OS to minimize radiation doses to construction workers, then slid over the OS on a runway system using hydraulic power. The NSC is an enormous arch-shaped steel structure which will protect the OS from the elements, confine any radioactive dust releases, and support a massive and unique crane system called the Main Cranes System (MCS). The approximate dimensions of the NSC arch are 250 m (820ft) wide, 150 m (492 ft) long, and 100 m (328 ft) tall. A section of the NSC is illustrated in Figure 1.

The construction site of the NSC is located in the OS Local Zone and OS Industrial Site. The Local zone adjoins the western end of CHNPP Power Unit 4. The OS industrial site adjoins the west side of the local zone. The local zone is more radioactively contaminated and has higher radiation dose rates than the industrial zone. Both are located inside the CHNPP physical protection zone.

The NSC construction site is divided into Service, Transfer and Erection zones (from east to west).

After NSC construction has been completed in the erection zone, the Arch will be slid in the eastern direction to its design position over the OS Service area. The transfer zone is the territory between the Erection area where the Arch is constructed and its final operational location the Service area.

The assembly of the arch elements is in progress in the erection zone. An in-progress status of the assembly is provided in Figures 2 and 3.

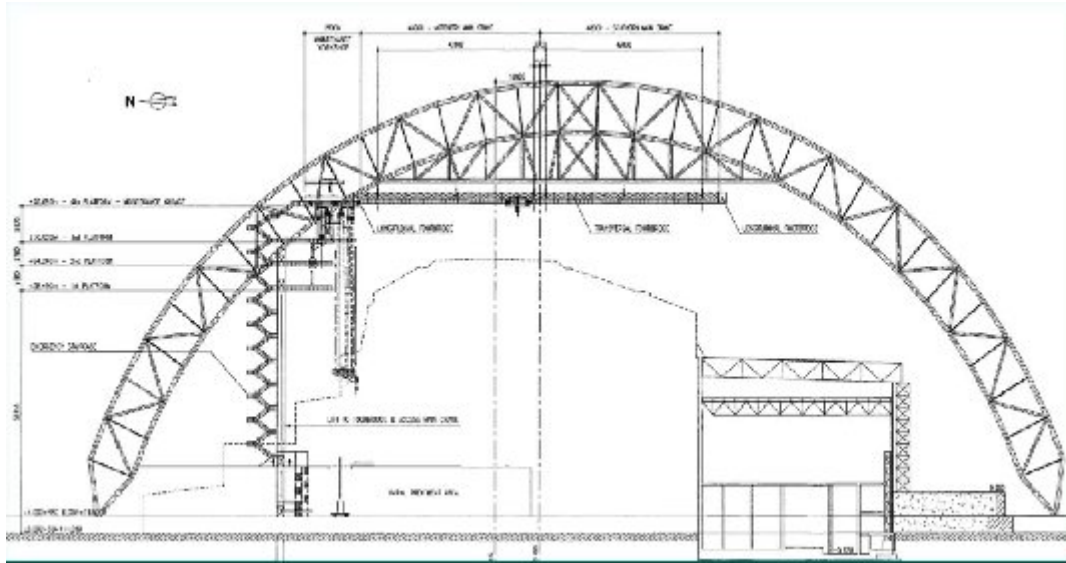

**Figure 1 New Safe Confinement section looking East**



**Figure 2 Arch Sections Assembly and the first lift, November 2012**



**Figure 3 Arch Sections Assembly and the first lift, November 2012**

A donor community, consisting of 46 countries and organizations, support the work of the SIP. Funds are administered by the European Bank for Reconstruction and Development (EBRD). The facility owner is State Specialized Enterprise Chernobyl Nuclear Power Plant (ChNPP). Oversight of SIP work is provided by a Project Management Unit (PMU) staffed by representatives of ChNPP and a consortium of Bechtel International Systems Incorporated (Bechtel) and Battelle Memorial Institute (Battelle).

An international tender was initiated in 2004 for the design, construction and commissioning of the NSC. The Contract was subsequently awarded in 2007 to NOVARKA, a joint venture between VINCI Construction Grands Projets and Bouygues Travaux Publics. NOVARKA subsequently awarded a subcontract for the basic and detailed engineering, procurement, manufacture, factory acceptance tests, delivery and erection of the complete Main Cranes System (MCS) to PaR Systems, Inc. (Minneapolis/Saint Paul, Minnesota, USA).

The MCS is installed just below the NSC ceiling, approximately 80 meters (275 ft) above ground level. The MCS will be installed commissioned and tested within the arch before the final arch sliding.

### **Work Environment:**

A significant portion of SIP work exposes workers to radiation and radioactive material, which is further exacerbated by the numerous general industrial hazards found within the Object Shelter and on adjoining radioactively contaminated areas. The radiological hazard varies between work areas.

International best practices dictate use of engineered controls to eliminate or minimize exposure to both severe radiological and industrial hazards, such as those encountered on SIP.

Unfortunately, SIP work areas, particularly those within the Object Shelter, often cannot be brought into compliance with such international safety standards. While radiological hazard levels are generally lower in the outdoor environment of the Industrial Zone, they remain significantly higher than those typically encountered in industrial construction sites, and much higher than the *de minimus* levels Ukrainian regulations require for exemption from regulatory monitoring and controls. As a result, work must often be performed in highly hazardous conditions, with only administrative controls (e.g., training, monitoring, procedural control, etc.) and personal protective equipment (PPE) for mitigation. The cumulative effect of the industrial and extreme radiological hazards has led to categorization of this work as “Especially Harmful and Dangerous Labor Conditions” (EHDLC) under Ukrainian worker safety legislation.

### **Description of the Main Cranes System (MCS):**

The following presents some engineering details and unique features of the MCS:

#### PaR Scope of Work

- Two 96m (315 ft) bridges (approximately 7m (25 ft) wide)
  - Six runways, top running, under hung, top-riding design
- One Classic Carriage Hoist
  - Single hoist configuration; 50 tonne Capacity
- One Secure Carriage Hoist
  - Dual hoist configuration; 40 tonne Capacity (personnel)/50 tonne Capacity (materials)
  - May be utilized to transfer maintenance personnel throughout the facility in a shielded protective box
- One Mobile Tool Platform Carriage (MTP)
  - Quantity six (6) hoists operating simultaneously to hoist and lower a lower platform with a tool arm on the underside
  - Lower platform attachments such as Hydraulic Power Unit, Vacuum System, Arm/tooling supplied by others
- Runway Rails and Conductor Bars
- Control System and Camera System
- On site Erection Supervision

Figures 4 and 5 provide an appreciation of the extraordinary size of the MCS components. To demonstrate scale, a Boeing 777 is illustrated parked below the bridges and in front of the NSC.

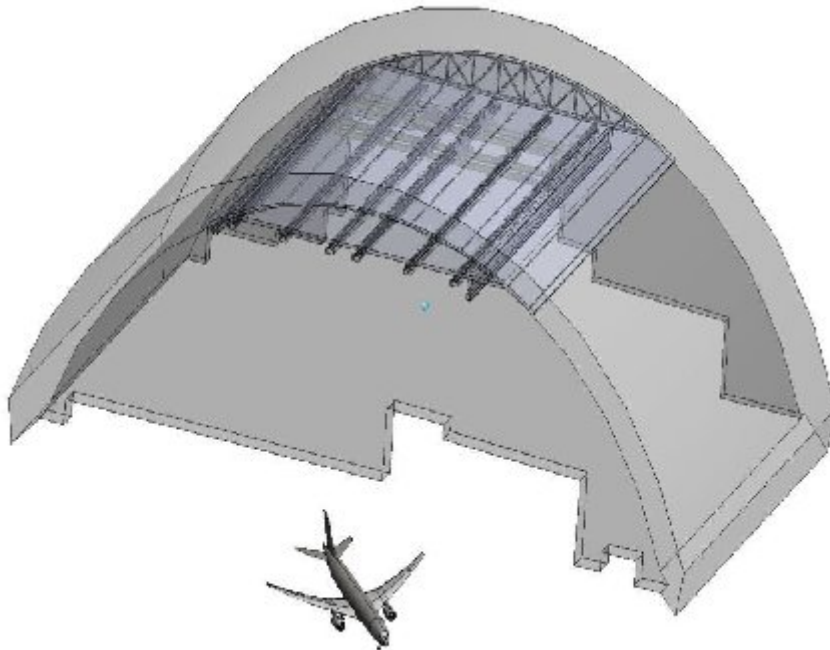

**Figure 4 NSC compared to Boeing 777, same scale**

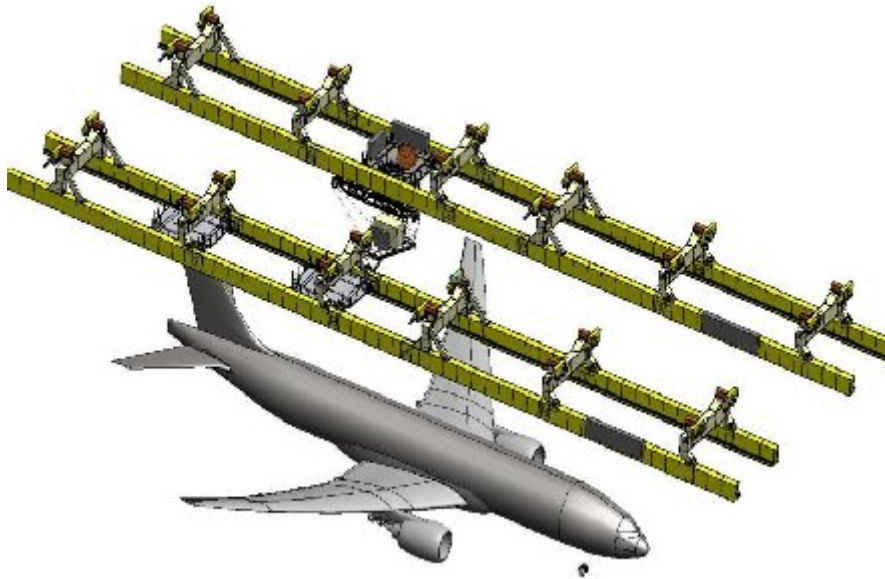

**Figure 5 MCS bridges compared to Boeing 777, same scale**

Brief description and functions of each major MCS component are provided below:

**Crane Bridges:**

Two crane bridges are top-running underhung, suspended from crane rails oriented East-West and located at an elevation of 76 m above grade inside the NSC. Due to their considerable length (96 m), each bridge moves on six crane rails. Each girder has 5 individual pinned spans to provide the flexibility to maintain wheel contact for different load cases and Arch movement. The bridges are designed such that two fully loaded carriages may be on the same bridge with a separation of at least 22 meters centre-to centre. The control cabinets are located on the bridge with wireless communication to the control room. Although local control from these panels is possible, the cranes are normally operated from a control room located in a building separate from the NSC. The crane bridges are also equipped with access ways for maintenance of the bridges.

**Classic Carriage:**

The Classic carriage is a top running trolley with one hoist. It has 4 driven wheels and 4 idler wheels to support garage transfer activities. The carriage wheelbase is 6.5m (21 ft) by 7.0m (23 ft). Carriage travel speed is 0 to 15 m/min. Lifting capacity is 50 tonne. Lifting speed: 0 to 10



m/min. Vertical lifting distance of 73m (240 ft). Continuous hook rotation at 0.25 RPM. Carriage controls are located on the trolley with wireless communication to the control room. The functionality of the Classic carriage is for the transfer of unstable structures to a storage area.

**Secure Carriage:**

The Secure carriage is a top running trolley with two hoists. It has 4 driven wheels and 4 idler wheels to support garage transfer activities. The carriage wheelbase is 6.5m (21 ft) by 7.0m (23 ft). Carriage travel speed is 0 to 15 m/min. Lifting capacity is 50 tonne (materials) or 40 tonne capacity (personnel). Lifting speed: 0 to 10 m/min. Main hoist vertical lifting distance of 71.2m (234 ft). Recovery hoist lifting up 10m (33ft), down 15m (49 ft). Continuous hook rotation at 0.25 RPM. Carriage controls are located on the trolley with wireless communication to the control room. The functionality of the Secure carriage is for the transfer of unstable structures to a storage area. In addition, it is used for the transport of personnel in a shielded protective box. The Secure and Classic carriages are shown below in Figure 6 during assembly in Shoreview, Minnesota.



**Figure 6 - Classic (front) and Secure (rear) Carriages during assembly, January 2013**

In order to allow worker access to high radiation areas of the Object Shelter, the NSC is equipped with a shielded protective box. Workers can be transported in the shielded protective box only by the MCS secure carriage. The secure carriage can be used in cooperation with the classic carriage to lift beams with a length >50m and weight of up to 100 tonne.

#### **Carriage Equipped with Mobile Tool Platform (MTP):**

The MTP is a custom-made tensile truss that will serve as a stable platform for remotely operated tools. The MTP is composed of two triangular shaped platforms, upper and lower, connected by six wire ropes. The six hoists on the upper platform allow raising and lowering of the lower platform to the work area. The hoists also precisely control tension on each wire rope so that the lower platform can sustain significant horizontal loads and torque generated by the use of the tools. The MTP design is much more than the standard anti-sway technology used in the crane industry – it is an inverted Stewart Platform and has the same properties as a rigid structural element. The rigid platform provides an ideal delivery system for remote tooling that will be

required in the Chernobyl dismantling efforts in the future. For the Chernobyl application, a robotic arm is attached to a rotating mounting plate to allow work to be performed in a complete hemisphere below the MTP. Remotely operated high radiation cameras will provide full coverage of the Chernobyl plant and all operations during the next phase of the project as workers are located remotely and will perform nearly all operations using cameras.

The MTP is illustrated in Figures 7 and 8.

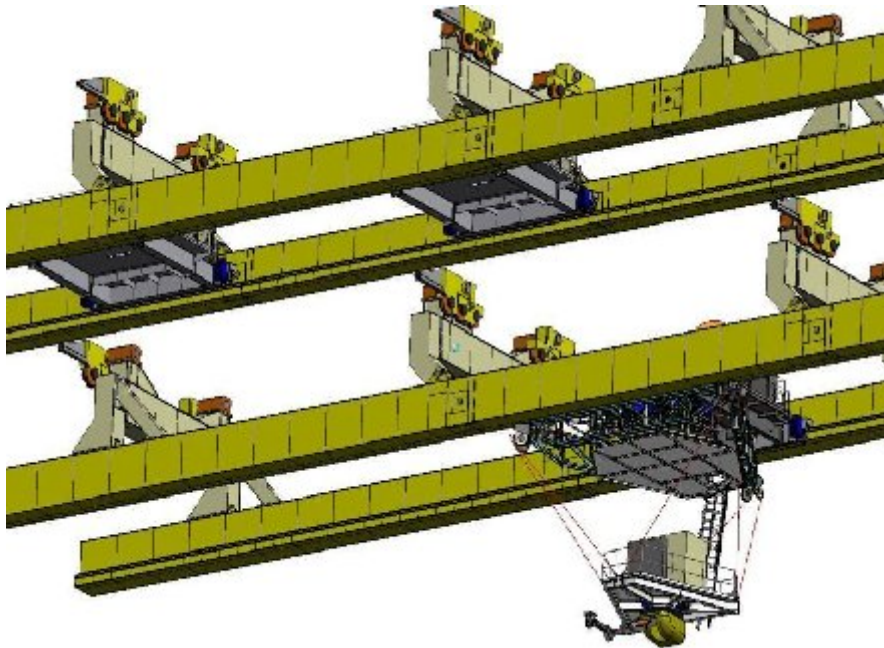

**Figure 7 Mobile Tool Platform suspended from East Bridge**

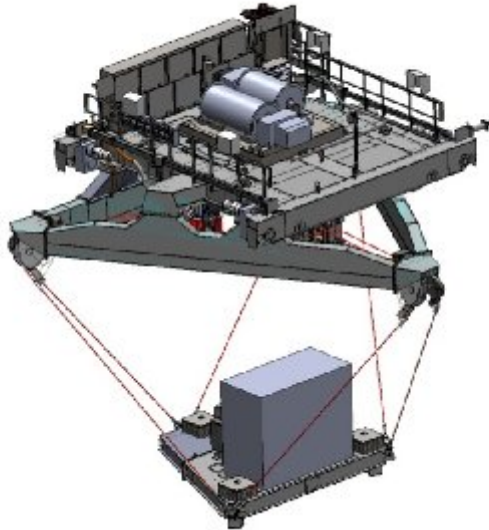

**Figure 8 Mobile Tool Platform, detailed view**

The Mobile Tool Platform is an exclusive design by the crane supplier and has the following features:

- Provides 1.5 tonne side load capacity with  $< 0.5\text{m}$  deflection at full extension 35m (115 ft). Has the capability to move the lower platform laterally while the upper platform remains still through hoist control (flying)
- Is used for tool deployment, including manipulator arm, core drill, concrete crusher and 10 tonne vacuum cleaner
- Power (175kW) is supplied throughout the vertical travel range 70m (230 ft)



**Figure 9 - 1/4 Scale Model of Tensile Truss - Fully Functional**

The authors believe that this is one of the largest, if not the largest implementation of a tensile truss design for these purposes. Because it is first of a kind, the manufacturer constructed a 25% scale prototype in their facilities in the USA (shown in Figure 9). The prototype was used for proof of principle and to develop the robust and proven technology control system necessary for operation. The scale model tensile truss is fully functional and has been used by PaR Systems to demonstrate the software necessary to perform straight-line raising and lowering functions as

well as develop complicated movements such as horizontal flying and rotation using motor control. Flying is achieved by precision control of the six hoists which moves the lower platform horizontally merely by varying the rope lengths. The lower platform can also be manipulated to various orientations which increases the functionality of the attached tools (see Figure 10).



**Figure 10 Scale Model Tension Truss Lower Platform - using hoist control to achieve various orientations**

#### **MTP Prototype Testing:**

Because of the physical size of the MTP, actual side load testing over the entire travel range of the MTP cannot be accomplished until final site installation. To help validate the full scale MTP performance PaR used the 1/4 scale version of the MTP to develop a Predictive Software package (see Figure 11 for a comparison of sizes; scale model is also shown in Figure 9). Extensive load testing is being done on the 1/4 scale MTP. These results will be used to validate the accuracy of the Predictive Software. Full scale MTP side load and deflection information will then be estimated using the Predictive Software package.



**Figure 11 Full Scale and 1/4 Scale MTPs for Comparison**

### **Garages: Carriage transfer and maintenance**

The MCS consists of two bridges and three carriages. Any two carriages can be placed on either bridge at one time. There are two garages to enable transfer of carriages between bridges and to provide carriage maintenance space. Two carriages can be stored in either garage simultaneously.

For example, suppose that it is desired to transfer the secure carriage from the Eastern bridge to the Western bridge. The Eastern bridge is aligned with the single-story southern garage, the bridge is locked into place, and the carriage is driven into the garage. Then the Eastern bridge is moved away, the Western bridge aligned with the garage and locked into place, and the carriage is driven onto the bridge.

The Northern garage is a shielded three-story facility outfitted with hoists and other maintenance equipment to enable maintenance, repair, and, if necessary, complete disassembly of carriages at elevation. The lower platform of the MTP is lowered to a special stand at ground level for maintenance, to empty the vacuum collection system, and tool change-outs or replacement of consumables.

### **Crane Control and Operation**

If the MCS were to drop a heavy load over the Chernobyl Unit-4 reactor hall, a radioactive dust cloud would be generated. The NSC would prevent the dust from reaching the environment or endangering workers and the public outside of the NSC. However, the dust would be a significant hazard to anyone inside the NSC at that time. No personnel will be inside the NSC during such lifts.

MCS operations will be performed by an operator located outside of the NSC, without line-of-sight of the crane or its load. Consequently, the MCS is more heavily instrumented than a similar crane without this constraint. The radiation environment inside the NSC also impacts instrumentation and control design.

The MCS Control Architecture consists of programmable logic controllers (PLC), wireless and Ethernet hardware technologies along with human and machine interface (HMI). All operator commands are delivered to the crane system using a wireless control system. The operator sits at a console equipped with a joystick and several touch screen monitors that provide MCS position and status, including load weighing system outputs. Other monitors display closed circuit television images of load and crane movement. There are also cameras located on the carriages and bridges used for common preoperational checks.

Two of the more complex operations executed by the control system are simultaneous operation and synchronous operation. Simultaneous operation allows single point control for the simultaneous lifting or translocation of two carriages on the same or different bridges. This type

of operation is necessary for lifting and moving long loads. Synchronous operation allows single point control for the rotation of a long load being carried by two carriages on different bridges.

**Conclusions:**

Since the issuance of the MCS contract, several design review meetings were held in the US and in Ukraine. At the time of publication, 99% of the MCS design is complete. PaR has issued purchase orders to its subcontractors for the supply of various components. The MCS carriages and bridge girders are very close to completion of fabrication. The factory acceptance testing of the MCS is scheduled in May 2013 and the shipment is scheduled in March 2014. The contract completion date for the New Safe Confinement is October 2015.

---