

## **Passive Neutron Non-Destructive Assay for Remediation of Radiological Waste at Hanford Burial Grounds– 13189**

A. Simpson<sup>\*</sup>, M. Pitts<sup>\*</sup>, J. D. Ludowise<sup>\*\*</sup>, P. Valentinelli<sup>\*\*</sup>, C. J. Grando<sup>\*\*\*</sup>, D. L. Haggard<sup>\*\*\*\*</sup>

<sup>\*</sup>Pajarito Scientific Corporation, 2976 Rodeo Park Drive East, Santa Fe, NM 87505

[asimpson@pscnda.com](mailto:asimpson@pscnda.com), [mpitts@pscnda.com](mailto:mpitts@pscnda.com)

<sup>\*\*</sup>Washington Closure Hanford, 2620 Fermi Ave., Richland, WA 99354

[jdudowi@wch-rcc.com](mailto:jdudowi@wch-rcc.com), [pjvalent@wch-rcc.com](mailto:pjvalent@wch-rcc.com)

<sup>\*\*\*</sup>ELR Consulting, Inc., 15247 Wilbur Rd., La Conner, WA 98257

[cjgrando@wch-rcc.com](mailto:cjgrando@wch-rcc.com)

<sup>\*\*\*\*</sup>WorleyParsons Polestar, 601 Williams Blvd., Richland, WA 99354

[dlhaggard@wch-rcc.com](mailto:dlhaggard@wch-rcc.com)

### **ABSTRACT**

The Hanford burial grounds contains a broad spectrum of low activity radioactive wastes, transuranic (TRU) wastes, and hazardous wastes including fission products, byproduct material (thorium and uranium), plutonium and laboratory chemicals. A passive neutron non-destructive assay technique has been developed for characterization of shielded concreted drums exhumed from the burial grounds. This method facilitates the separation of low activity radiological waste containers from TRU waste containers exhumed from the burial grounds.

Two identical total neutron counting systems have been deployed, each consisting of He-3 detectors surrounded by a polyethylene moderator. The counts are processed through a statistical filter that removes outliers in order to suppress cosmic spallation events and electronic noise. Upon completion of processing, a “GO / NO GO” signal is provided to the operator based on a threshold level equivalent to 0.5 grams of weapons grade plutonium in the container being evaluated. This approach allows instantaneous decisions to be made on how to proceed with the waste.

The counting systems have been set up using initial on-site measurements (neutron emitting standards loaded into surrogate waste containers) combined with Monte Carlo modeling techniques. The benefit of this approach is to allow the systems to extend their measurement ranges, in terms of applicable matrix types and container sizes, with minimal interruption to the operations at the burial grounds.

## INTRODUCTION

The Hanford burial grounds contain a broad spectrum of low activity radioactive wastes, transuranic (TRU) wastes, and hazardous wastes including fission products, byproduct material (thorium and uranium), plutonium and laboratory chemicals.

Individual waste shipment records for all wastes shipped to the burial grounds were not generated, since there was no statutory requirement to do so at that time. Therefore, segregation of TRU wastes from non-TRU wastes was not conducted over the lifetime of the burial grounds.

Non-destructive passive assay systems are used to identify and measure the radiological contents of the waste containers of varying geometries and contents. The Hanford Slab Counter (HSC) systems, supplied by Pajarito Scientific Corporation, have been developed to facilitate separation of low activity radiological waste containers from TRU waste containers exhumed from the burial grounds, using total neutron counting.

The HSC systems detect and analyze the passive neutron emissions from the plutonium within the container. The primary advantage of this method is that fast neutrons can penetrate through concrete shielding and other dense matrices (e.g. oils and solvents) that would normally preclude or restrict the use of gamma-ray based techniques. This allows operators to perform rapid on site characterization on exhumed drums.

Two systems are used, each comprising an array of He-3 tubes embedded in polyethylene, with associated counting electronics. The counters are mounted onto transportable carts that are engineered to allow easy set-up and relocation / reconfiguration (see Figure 1).



Fig. 1. Hanford Slab Counter.

The basic principle of operation is to measure the total neutron emissions from the waste and

evaluate against pre-defined GO / NO GO criteria using assumed isotopics, assumed chemical composition and known matrix type. Neutron counts from each detector are summed together to create a single neutron counting channel. The neutron counts are acquired in a series of discrete intervals. The software determines the “validated” neutron count rate by elimination of high statistical outliers from the acquired data intervals.

The background neutron count rate is periodically measured and the software automatically corrects for matrix-dependent effects (e.g. cosmic ray spallation and shielding). This yields a net validated neutron count rate for each analysis which is evaluated against a matrix-specific threshold level (equivalent to 0.5g Pu).

The system provides a clear visual indication of the GO / NO GO result. Output files are created by the software to record the raw data and provide details of the analysis. The software also calculates an estimate of the plutonium mass of the container for indicative purposes.

An important feature included within the software is an interlock that precludes the operators from performing waste drum measurements if the background rate is determined to exceed bounding limits determined during system set-up. The system detection limits are dependent on background and therefore this feature ensures that the system is maintained within its validated operational envelope. The operators also perform a daily check with a known Cf-252 source to ensure the system’s total neutron efficiency is within acceptable limits.

## **SET-UP OF THE SLAB COUNTERS**

The slab counters were set up at the Hanford site in March and April of 2011. During the initial configuration measurements, a set of surrogate drums were loaded onto a turntable at the final measurement location and measured with a Cf-252 source located at various radial tubes and heights. Drums used were 55-Gallon (208 liter) in 85-Gallon (322 liter) overpacks containing:

- Concrete annulus
- Cutting oil / metal shavings
- Solvents (mineral oil)
- Simulated debris waste (combustibles)

The specific total neutron emission rate of the expected plutonium was determined based on published data [1] to be 92.2 n/s-g(Pu) by assuming the material was a mix of 50% oxide and 50% metal. Neutron emissions from other emitters (e.g. Cm-244) were assumed to be negligible.

Threshold rates equivalent to 0.5 grams of plutonium were calculated specific to the container size, matrix type, assumed waste stream isotopics and slab counter geometry. Corrections were performed to determine the rate from a homogeneous geometrical source distribution (using a

radial averaging method) and to account for the neutron energy difference between the Cf-252 source and plutonium using correction factors derived from [2].

The counters were set up within a shipping container as illustrated in Figure 2. Exhumed waste drums were positioned outside the container on a turntable and measured for 20 minutes. The workstation (software interface) was located several meters from the counters to ensure minimal dose uptake to the operators.



Fig. 2. Hanford Slab Counter Deployment

## BACKGROUND RADIATION LEVELS

The system is designed to achieve its required performance (lower limit of detection) in a neutron background flux of less than  $0.020 \text{ n/s-cm}^2$ . After the system was installed on site, an initial site survey was performed where it was determined that the background rates for both systems were below 2.2 cps.

Assuming that the background flux is isotropic it is simple enough to quantify background flux,  $F$  from a measured background rate,  $B$ , from Equation 1.

$$F = \frac{B}{\varepsilon 4\pi r^2} \quad (\text{Eq.1})$$

where  $\varepsilon$  is the absolute total neutron efficiency for a point source located at distance  $r$  from the front surface of the slab counter. During set-up the efficiency at 30cm distance was measured to be 1.6% on both systems. The background flux for the systems was evaluated at  $0.012 \text{ n/s-cm}^2$  and therefore the upper limit requirement ( $< 0.020 \text{ n/s-cm}^2$ ) was met.

## MCNP MODEL

A Monte Carlo N-Particle (MCNP) [3] model was used to extend the container size range of the system and evaluate the measurement uncertainty. In the model, the counter's geometry was simplified to block structures (represented by cuboids and cylinders) representing all components that have a significant impact on neutron efficiency. The major structures modeled included: He-3 detectors, electronics, polyethylene block and shielding, aluminum enclosure, cart (including frame, neoprene rubber wheels and steel ballast), waste drum, turntable, container with wooden floor, container door, ground (soil) and the surrounding air.

The model geometry is shown in Figure 3 (the surrounding container is not depicted). The model calculates the (n,p) reaction rate in the He-3 per source neutron. The sum of (n,p) rates in all detector per emitted neutron represents the absolute total neutron counting efficiency of the HSC.

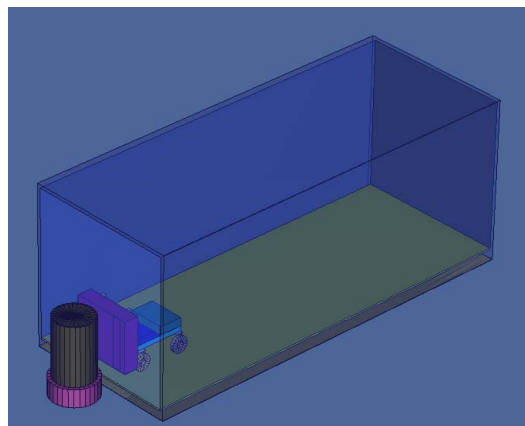

Fig. 3. MCNP Model Geometry – view of HSC and drum

A set of models were run to benchmark the model against real (on site) measurements. A Cf-252 source was positioned at various reference locations. The source was located 30cm in front of and behind the slab (i.e. sitting in air) and also inside surrogate drums.

The calculated efficiency is shown in Figure 4 compared to the site measured results obtained with both (identical) systems “A” and “B”. It can be seen that, for the source located in air, the agreement between the model and the real measurements is very good (i.e. within 5%). For the matrix drums the results are generally consistent (i.e. within 10-20%) which is reasonable given the approximations used in the modeling of the matrix contents.

The modeling demonstrates that the system efficiency to point sources within drums is a strong function of moderating content of the matrix (which is in turn dominated by the concentration of hydrogen). For example the efficiency for the concrete drum is strongly dependent on the water content of the concrete and the ratio of organic to inorganic materials in the debris drum.

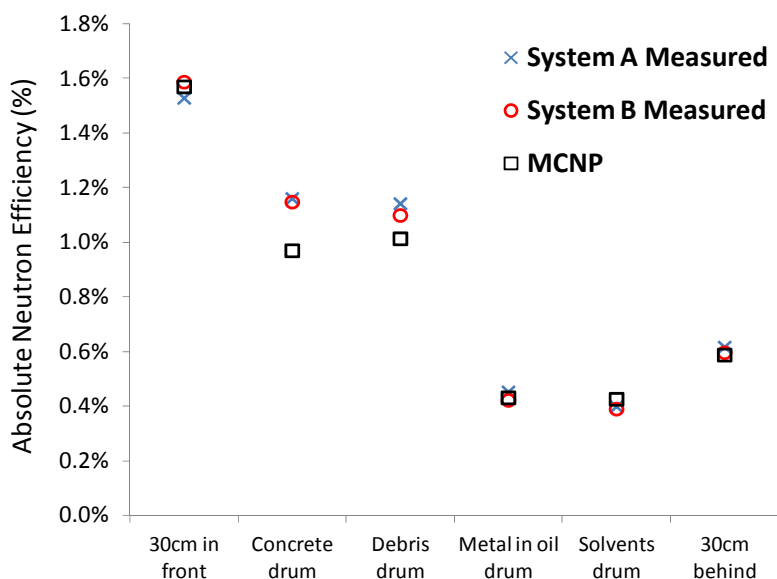

Fig. 4. Benchmarking of MCNP

## MEASUREMENT UNCERTAINTY

The GO / NO GO threshold settings must take into account the various components of measurement uncertainty. Estimates of the individual uncertainty terms are summarized in Table I.

TABLE I. Estimated Uncertainty Terms for the HSC systems

Uncertainty Component	Description	Uncertainty
Statistical	Estimated (random) uncertainty in net count rate. Quantified at 1 g Pu from Poisson counting statistics.	+/- 15%
Matrix effects	Uncertainty from variable matrix contents and fill height / drum voids.	+/- 33%
Background variation	Systematic effects in background correction and variability in background between measurements.	+/- 25%
Source distribution	Uncertainty in the source geometry (deviations from uniform distribution).	+/- 50%
Initial set-up	Systematic effects (or bias) in the decay corrected source neutron activity and certificate uncertainty	+/- 6%
Neutron energy	Systematic effects in the source energy correction term.	+/- 2%
Efficiency variation	Uncertainty arising from (i) environmental variability e.g. ground moisture and temperature (ii) drum positional accuracy.	+/- 5%
Neutron emissivity	Uncertainty in the plutonium chemical and isotopic composition.	+/- 40%

## **Matrix Effects**

MCNP runs were undertaken to study the effect of variations matrix content of the 85-Gallon overpack with a uniform source distribution. The scenarios modeled were: (i) typical debris waste from 0.08 to 0.32 g/cm<sup>3</sup> density, (ii) debris waste dominated by combustibles, (iii) debris waste dominated by metals/glass, (iv) concrete lined drum, (v) cutting oil with 1% iron (representing metal shavings in oil), (vi) hydraulic oil and (vii) solvents.

In several cases, models were run with the matrix filled to 50% fill height with source distributed over the filled region and void placed in the upper half of the drum. In consideration of the variability in efficiency with matrix contents, moderator content, density and fill height, the overall matrix uncertainty was estimated to be +/- 33% generically for all matrix contents. This is a reasonably conservative estimate that bounds the results of data obtained with the MCNP model and real measurements.

## **Source Distribution**

The uncertainty due to source distribution (i.e. deviation from assumed uniform case) was estimated from the measured relative standard deviation for the 9 source positions within each surrogate drums (6 positions were used for the concrete drum). It is estimated at +/- 50 % for the general debris drum. Higher uncertainty terms are theoretically possible with more interfering matrices such as solvents, but these drums are expected to have a more uniform internal source distribution so the debris case can be considered to be the worst case term.

## **Efficiency Variation**

The system's efficiency has a small dependency on scattered neutrons from the ground. The model was run with variable water content and chemical composition of the soil under the container. The results demonstrated that the efficiency variation is small (+/-1%).

There are also several temperature dependent effects that can impact efficiency: at low energy, cross-sections are inversely proportional to the square root of temperature (i.e. neutron energy). Thus He-3 (n,p) reaction rates are reduced in the detector, but hydrogen capture in polyethylene is also reduced which can increase efficiency. There is also a temperature dependent low energy neutron scattering effect from the molecular structure of the polyethylene which affects its moderating properties. The electronics will also exhibit a small degree of temperature sensitivity. The result of the MCNP modeling of temperature sensitivity has yielded an estimate that the overall HSC efficiency will vary by less than +/-2% over the operating range of -10F to 110 F (250K to 316 K).

In order to determine the effect of variation in the drum position with respect to the HSC, models were run with the source at various tangential distances from the detector mid-plane. Using this

data, an uncertainty term of +/-4% has been calculated for the HSC assuming a +/- 2.5cm tolerance in drum position on the turntable.

The study also addressed the effect of different neutron source energy spectra on the HSC efficiency. In the MCNP model, several types of simulated neutron spectra were evaluated: (i) Pu-240 spontaneous fission (ii) the (alpha,n) emissions from Pu-239 in oxide form (ii) Cf-252 spontaneous fission. It is estimated that variations in neutron energy will give rise to an uncertainty of less than +/- 2%.

### **Chemical and Isotopic Effects**

The uncertainty due to Pu isotopics and Am-241 mass fraction (i.e. from specific neutron activity) was calculated by evaluating the neutron output for a 50% oxide / 50 % metals mix of various plutonium grades typical for the burial grounds (from 5.4 -7.7 % Pu-240/Pu and 0.50 - 0.84% Am-241/Pu). This evaluates to an uncertainty due to isotopics of +/-23%.

The uncertainty due to chemical composition (i.e. from specific neutron activity) is estimated to be +/-32% based on the bounding variation in neutron emission rates for pure oxide and pure metal compared to a 50% / 50% mix.

### **LOWER LIMIT OF DETECTION**

The lower limit of detection (LLD) is defined as that level of radioactivity that, if present, yields a value above the critical level with a 95% probability, where the critical level is defined as the value which background measurements will exceed with 5% probability [4]. The systems are required to have an LLD of less than 0.5 grams of weapons grade plutonium inside a concreted drum.

LLDs have been estimated by performing a series of measurements on the 85-Gallon (322 liter) surrogate matrix drums with no sources added. For the 55-Gallon (208 liter) and 110-Gallon (416 liter) drums the LLDs were determined by scaling the 85-Gallon results using the relative efficiency determined in MCNP. The results of the LLD calculations are shown in Table II.



TABLE II. LLD Summary

<b>Drum Size (Gallons)</b>	<b>Matrix</b>	<b>Method</b>	<b>System A LLD (g)</b>	<b>System B LLD (g)</b>
55	Debris	MCNP	0.18	0.18
55	Metal in Oil	MCNP	0.41	0.47
55	Solvents	MCNP	0.45	0.49
55	Concrete Drum	MCNP	0.17	0.18
85	Debris	Site Measurements	0.18	0.18
85	Metal in Oil	Site Measurements	0.42	0.46
85	Solvents	Site Measurements	0.46	0.47
85	Concrete Drum	Site Measurements	0.17	0.18
110	Debris	MCNP	0.19	0.19
110	Metal in Oil	MCNP	0.34	0.38
110	Solvents	MCNP	0.37	0.39
110	Concrete Drum	MCNP	0.17	0.18

### **GAMMA-RAY SENSITIVITY TESTING**

The burial grounds contain drums of alpha contaminated (transuranic) waste and may also have high gamma emission e.g. from fission and activation products. The systems have been designed to count neutrons in the presence of a wide dynamic range of gamma radiation. The He-3 tubes are aluminum walled to reduce the gamma-ray “wall effect” and the high voltage settings were set for optimum balance between minimal gamma sensitivity and high neutron counting efficiency in order to achieve the required LLD.

The systems were demonstrated to be capable of normal operation in gamma fields up to 10 mGy/hr by exposing an Eu-152 source (228 MBq) to the front surface of the slab counter and confirming that the system operated within its normal envelope (i.e. in terms of measured background rate and neutron counting efficiency).

### **SITE MEASUREMENT RESULTS**

As of November 2012, the Hanford Slab Counter systems have measured a total of 125 concrete shielded drums exhumed from the burial grounds. The project had originally set a conservative “suspect TRU” threshold limit at 70 alpha nCi/g (2590 Bq/g), which has recently been changed to 45 nCi/g (1665 Bq/g). Drum assay values equal to or greater than this threshold will be sent for confirmatory non-destructive assay at the Hanford Waste Receipt and Processing (WRAP) facility. The instruments at WRAP are certified to characterize waste for sentencing to the Waste Isolation Pilot Plant (WIPP).

Nineteen (19) of the 125 concrete shielded drums have exceeded the specified threshold and are awaiting shipment to WRAP. The shielded drums range in weight from 330 to 910 kg. Over this

mass range, the concrete drum detection limit of 0.19 g Pu, equates to a minimum detectable concentration range of 18.5 to 57.4 nCi/g.

Each drum will be placed into an SWB for measurement by the Super High Efficiency Neutron Coincidence (SuperHENC) system at the WRAP facility and will also undergo high energy real time radiography (HERTR) to determine the actual shielding configuration and monitor for contraband items as determined by the Hanford Waste Acceptance Criteria (WAC).

All drums exhumed to date have surface dose rates that are significantly below the 10 mGy/hr gamma dose rate limit established for the slab counters.

## CONCLUSIONS

Two neutron slab counting systems have been commissioned on site at the Hanford burial grounds. The counters have performed a successful initial measurement campaign on exhumed waste drums.

An MCNP model has been created for the HSC systems. The model has been successfully benchmarked with real measurements and has been demonstrated to be an important tool for system performance characterization. The model has been used to extend the original baseline operating envelope in order to incorporate a wider range of drum sizes and matrix. This modeling work has provided significant cost savings and schedule improvement by reducing the number of surrogate drums required and avoiding the need to take the systems off-line for a lengthy period of time in order to perform additional set-up measurements.

The model has also been used to quantify the measurement uncertainty and study the detection limits. Environmental effects such as ambient temperature, ground moisture content and soil composition were modeled in order to quantify the impact of their variability upon system efficiency. Other variables that were modeled include: source energy and geometrical distribution, tolerance in the drum position on the turntable, source neutron energy, matrix composition and drum voids / fill height.

The on-site measurements and MCNP modeling results have confirmed that the LLDs for all types of matrix (with various drum sizes) are all less than 0.5 g WG Pu under normal site background conditions i.e. background neutron flux of 0.02 n/s-cm<sup>2</sup>.

There are several benefits that the HSC provides to the operators at the burial grounds:

1. Rapid container measurement time (20 minutes per container) has enabled site throughput requirements to be met.
2. The total neutron counting technique detects the emission of fast neutrons from the plutonium within the container. The neutrons can penetrate through concrete shielding and

other dense matrices (oils and solvents) that would normally preclude or restrict the use of gamma-ray based techniques.

3. The system software incorporates features that ensure continued validity of the results: (i) a statistical filter is employed to reduce the effect of noise and background spikes and (ii) the system has a protection mode that precludes waste measurements when the background rate exceeds specified levels.
4. The HSC is operated from a workstation that can be many meters away from the container being assayed. This enables operator dose to be As Low as Reasonably Achievable (ALARA).
5. In addition to the primary function of performing a GO / NO GO determination, the HSC software outputs a “Provisional Pu Mass” result that may be used for qualitative purposes.
6. The slab counters allow the site to perform rapid segregation of waste containers (based on Pu content) for a wide variety of waste matrices and drum sizes including concrete shielded drums.

The project has found approximately 20% of the known concrete shielded containers and is confident that any future “suspect TRU” concrete shielded drums will be identified by the HSC.

## REFERENCES

1. D. REILLY et al, Passive Non-Destructive Assay of Nuclear Materials, NUREG/CR-5550, March 1991.
2. H.O. MENLOVE et al, LA-13961-MS, Los Alamos National Laboratory Report on Use of Cf-252 as a Surrogate for Pu.
3. LA-UR-03-1987, MCNP — A General Monte Carlo N-Particle Transport Code, Version 5, April 24, 2003 (Revised 2/1/2008), Los Alamos National Laboratory.
4. NUREG-1507, Minimum Detectable Concentrations with Typical Radiation Survey Instruments for Various Contaminants and Field Conditions, January 1998.