

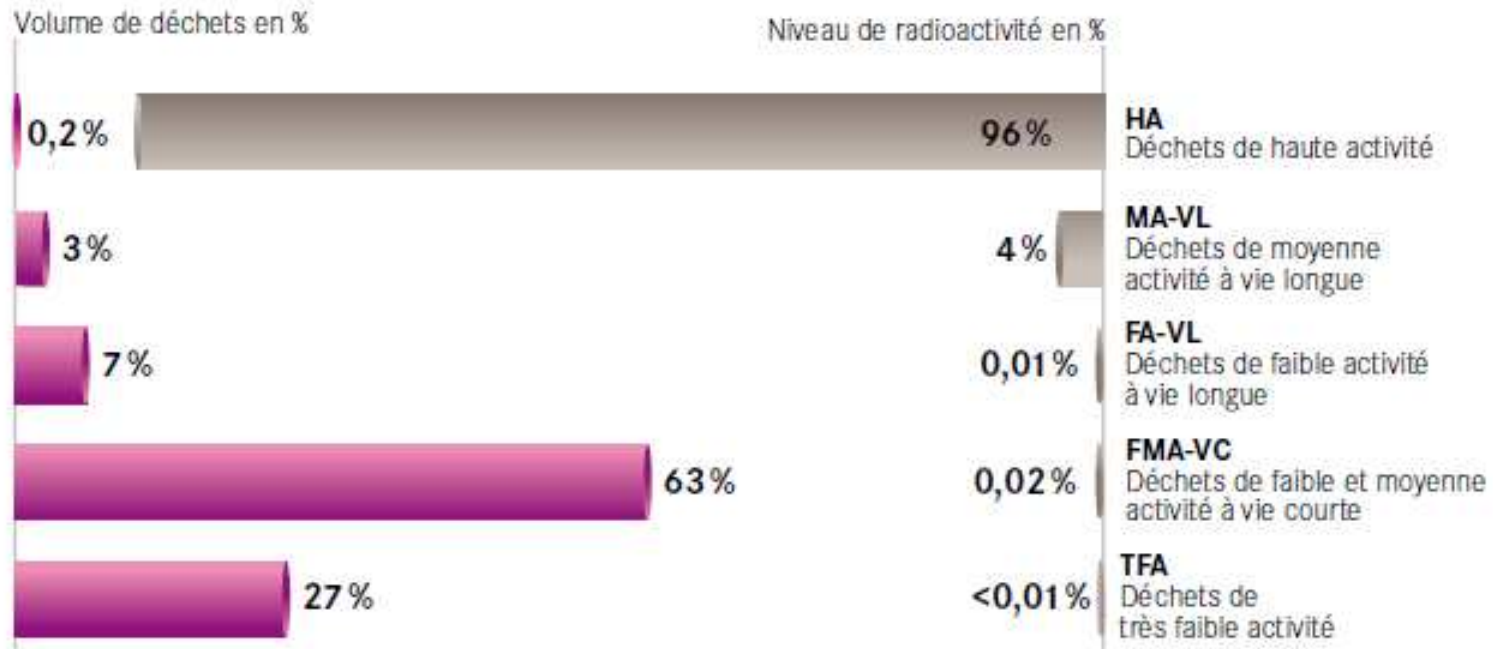

The French geological disposal project Cigéo: A converging approach

1,3 10⁶ m³ of radioactive wastes are already produced in France

90% of the volume of radioactive waste produced each year already benefit from a final storage solution in surface



The level of radioactivity and the radioactive period of the HL and ILL wastes do not allow them to be securely stored in surface or shallow depth storages.

Forecast of the volumes of waste for the years 2020 and 2030

For the nuclear power industry, the forecasts are based on the assumption of the duration of the plants of 50 years and the reprocessing of the spent fuel (data in cubic meters).

	Pour 2020	Pour 2030
HA	4 000	5 300
MA-VL	45 000	49 000
FA-VL	89 000	133 000
FMA-VC	1 000 000	1 200 000
TFA	762 000	1 300 000
Total général	~1 900 000	~2 700 000

Waste to be stored in the CIGEO project

CIGEO = Centre Industriel de stockage Géologique
(Industrial Geological disposal Centre)

- Long Lived ILW (MAVL)
 - Long Lived Intermediate Level Waste
 - Great variety of types of waste,
 - 245 000 primary packages – 110 000 m³
- Intermediate Thermicity HLW (HA)
 - Research and Military spent fuel and vitrified waste
 - 6000 primary packages – 800 m³
- Vitrified HLW (HA)
 - High Level Waste with High Thermic Power
 - Vitrified waste from spent fuel reprocessing
 - To be sent to underground repository after 2075
 - 57000 primary packages – 11000 m³

Main actors

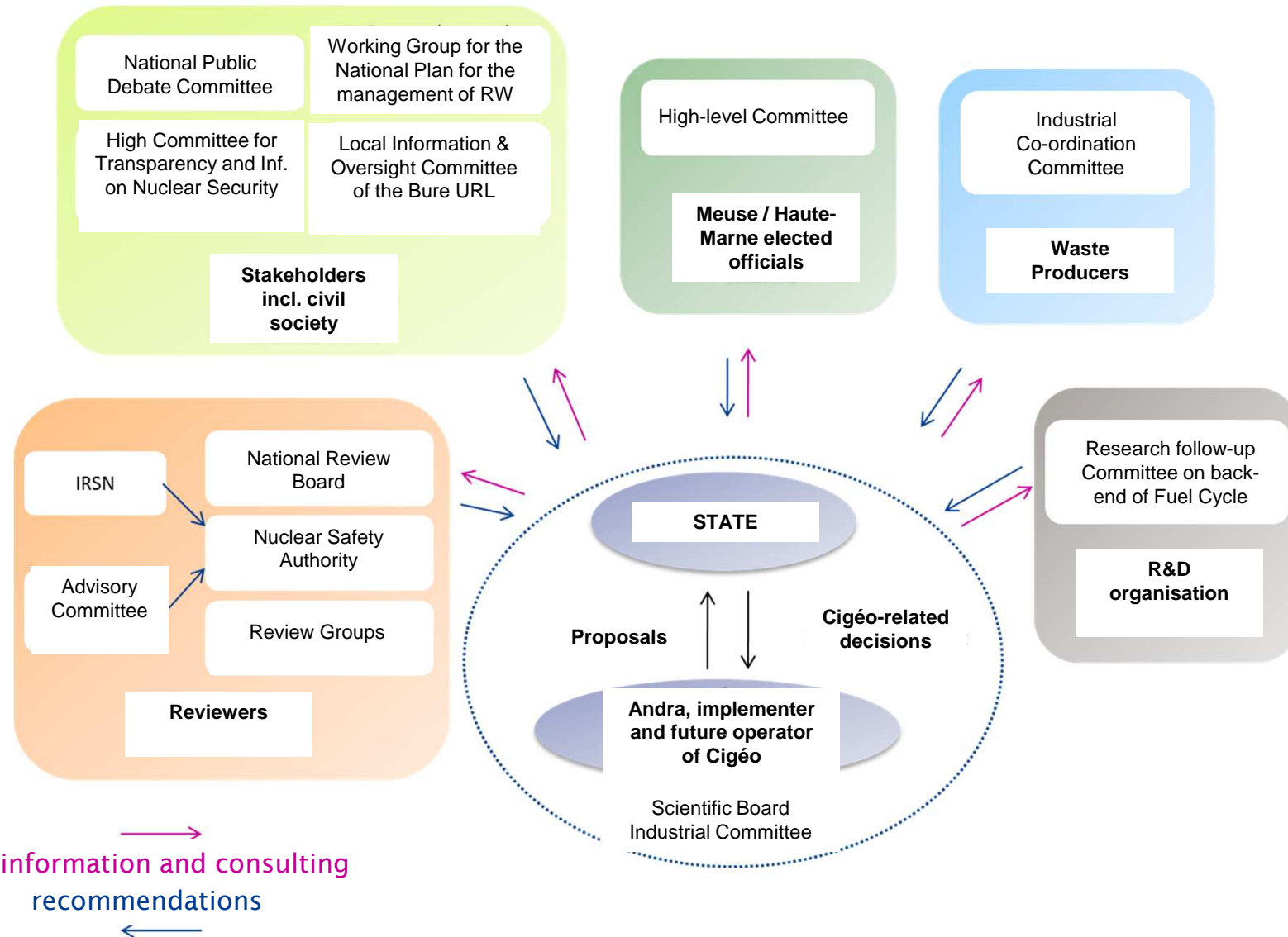

The Meuse/Haute-Marne URL: an essential tool

Surface and underground large scale tests make it possible to:

- » develop construction / operation techniques
- » investigate interactions between rock and components



Siting: a converging approach

3- Area defined for location of repository U/G facilities after local consultation (2009) and detailed geological survey from the surface

Detailed survey in 2010

4- Location of repository surface facilities under progress

Additional above-ground geological survey 2007-2008

2- Transposition zone of URL results (proposed 2005)

1- Siting started in 1992 with a National call for volunteering; URL licensed 1998

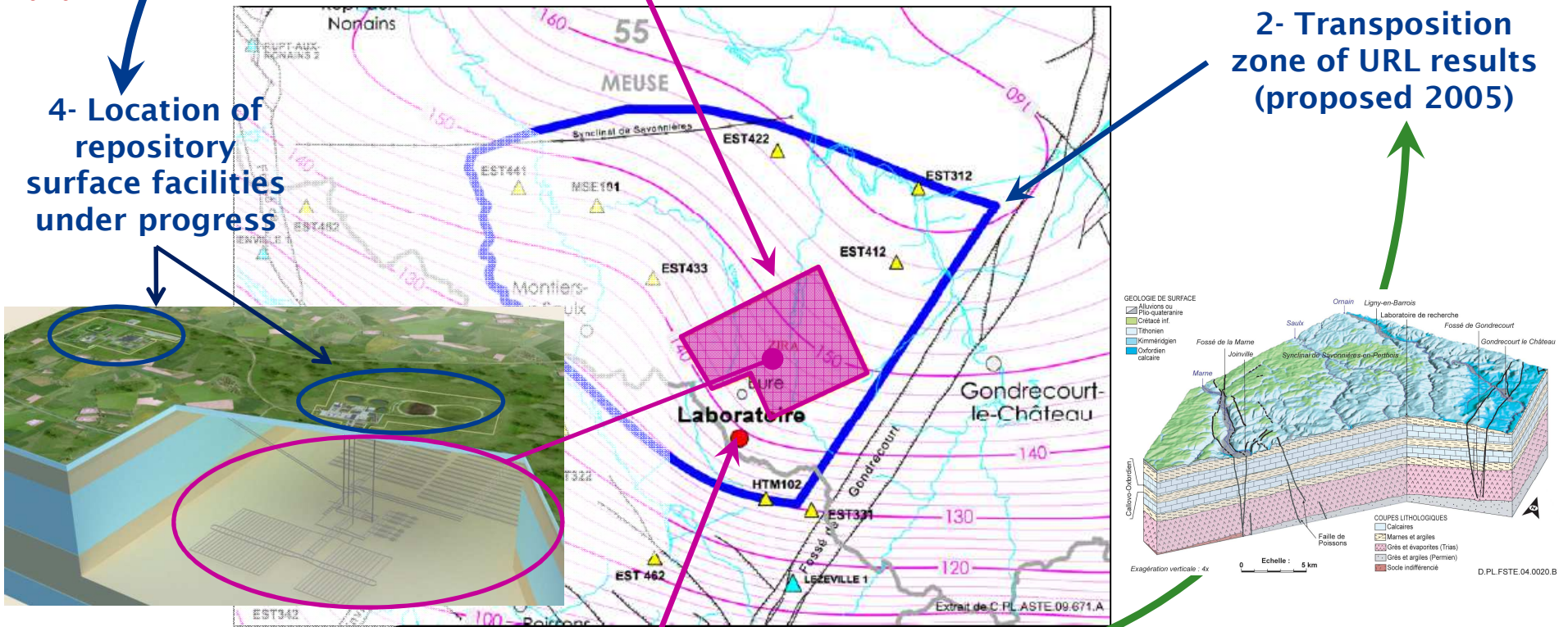

Final siting proposals for the public debate

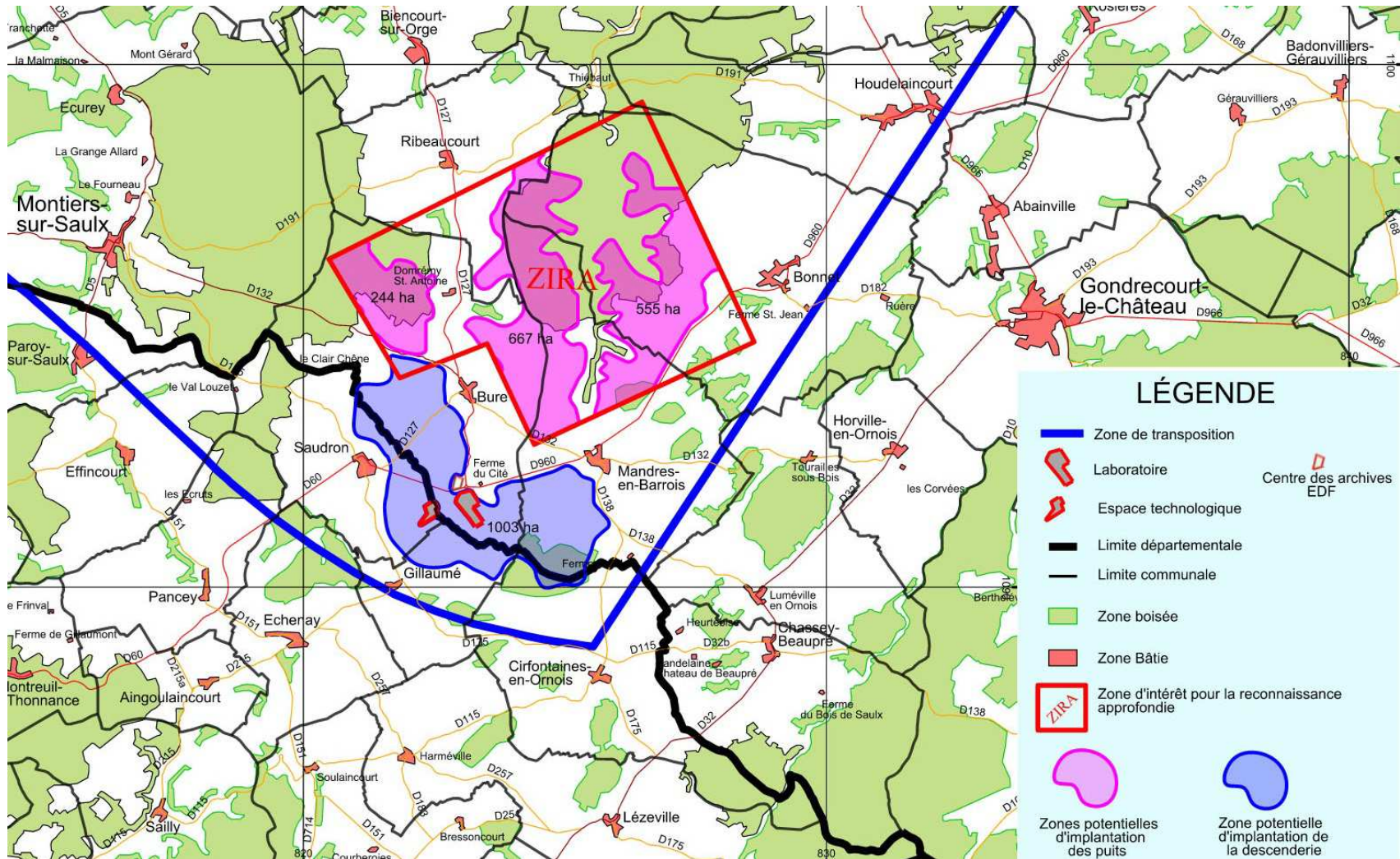



Design, construction and operation

Cigéo general design

Possible view of the repository after 100 years in operation

- ≈ 100 km of galleries
- ≈ 10 to 15 km² underground surface
- ≈ 7 to 8 million m³ excavated rock





Cigéo in numbers

Up to 2025 :

- Average number of workers: 1 800
- Peak number of workers: 2 700
- Water uptake: 500 m³/day (equivalent to the water supply for a 3000 inhabitants town)
- Dedicated electric supply: 400 000 volts
- Roughly 100 transportations per day (peak at 200)

The final numbers

- End of exploitation: 21 400
- HLW cells: 2 000
- ILW cells: 75
- Length of underground works: 275 km (drifts: 78 km ; cells: 196 km)
- Total volume of concrete for the construction of the underground facilities : 4,6 millions m³
- Total excavated volume: 9,2 millions m³

CIGÉO will be built and operated over one century

- Flexible approach: design, construction and operation in several phases
- Phase 1 shall include pilot structures
- After 2025 all construction and equipment work for the new operating phases shall be achieved concurrently with nuclear operating activities

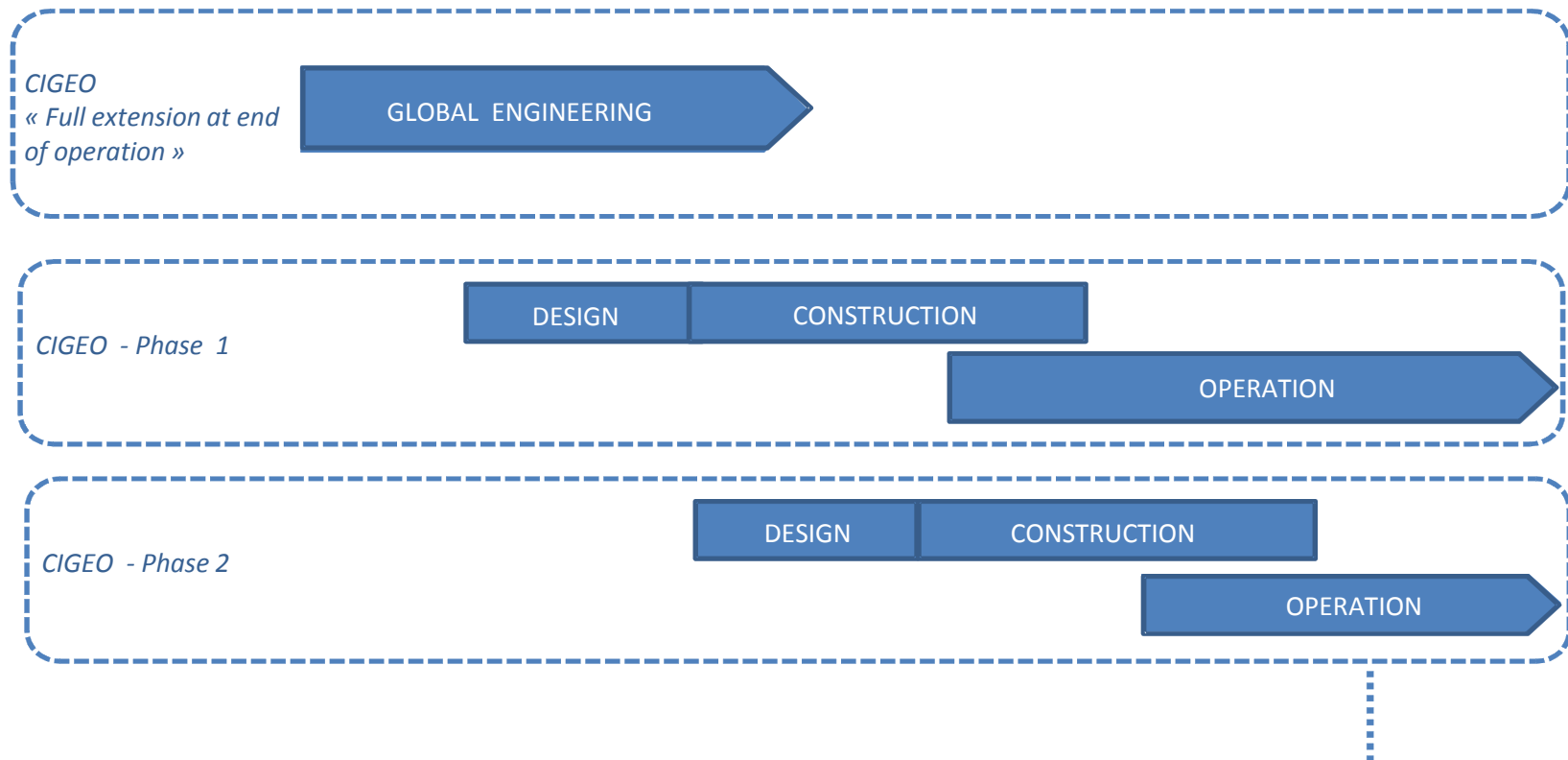

Before emplacement, IL-LLW will be grouped into precast concrete rectangular robust containers

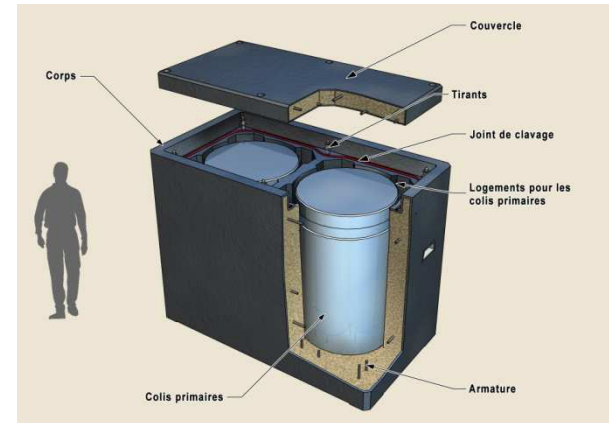
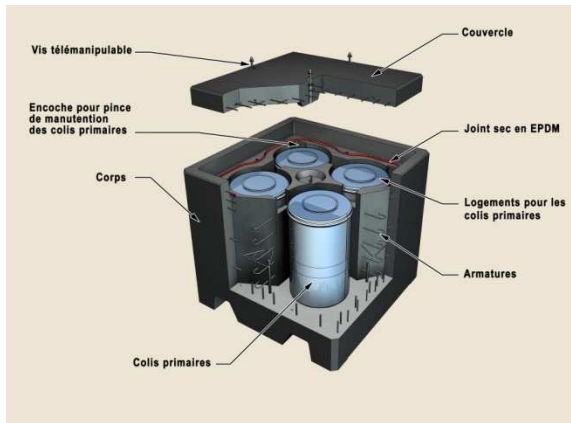

Prototype manufacturing



IL-LLW disposal cells

IL-LLW disposal cells are horizontal tunnels located at the median of the host clay layer:

- » Thick concrete lining to limit long term deformations;
- » Ventilation of IL-LLW repository cells as long as they are not closed.

Emplacement/retrieval processes and equipments are being developed and prototyped:

concrete Lining

IL-LLW disposal package

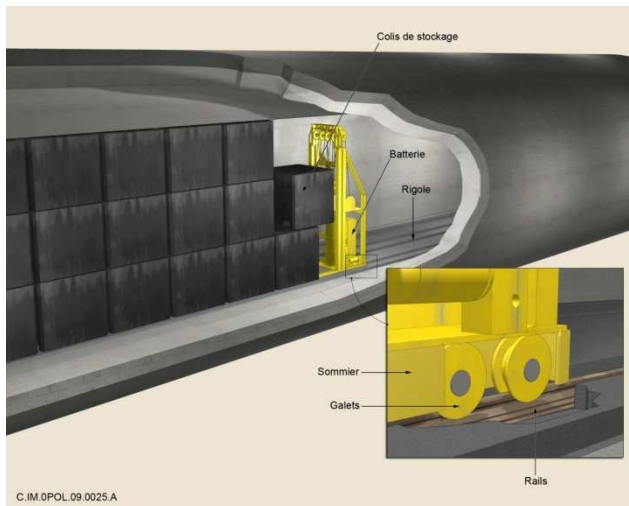
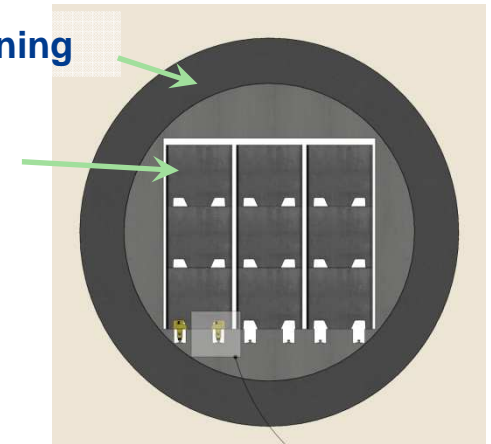

trolley stacker technique

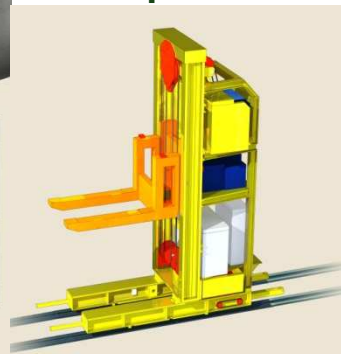

pre stacking technique

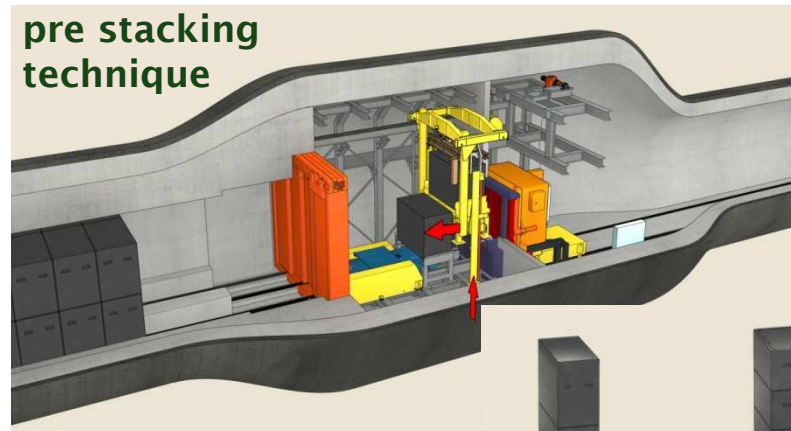

HLW will be placed in thick steel overpacks to prevent glass leaching during the thermal phase:

Ceramic skids for easy handling

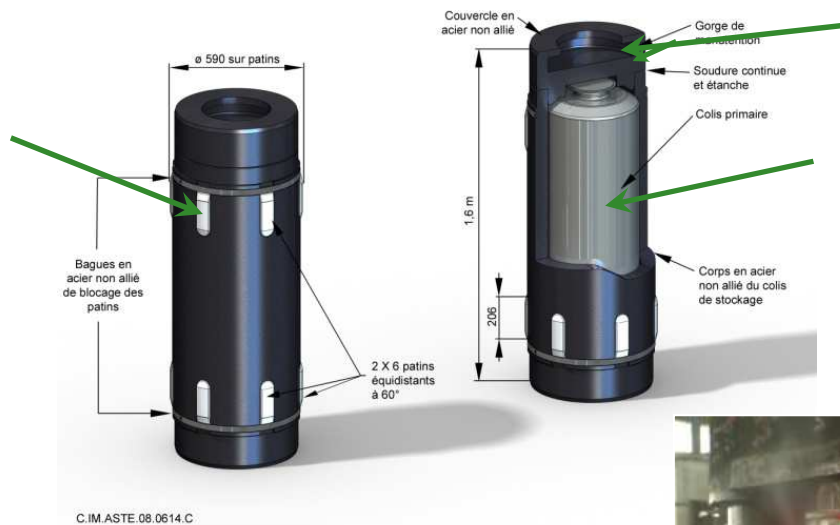

Gripping Interface

Vitrified HLW Stainless Canister



HLW will be disposed of in lined horizontal micro-tunnels:

- » Heat conduction in clay
 - max. temp in clay rock: 90 °C
- » Steel liner
- » Emplacement/retrieval equipments tested in worst conditions.

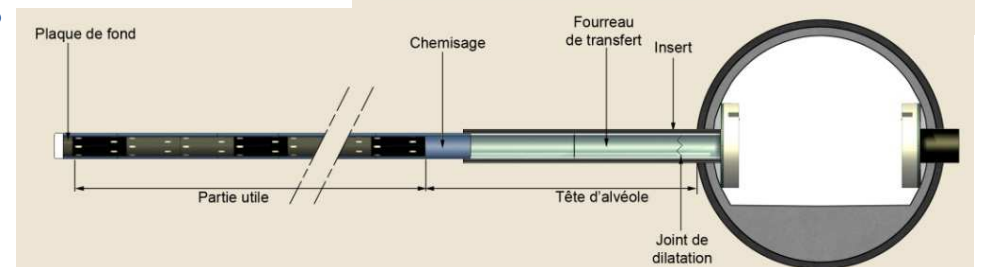
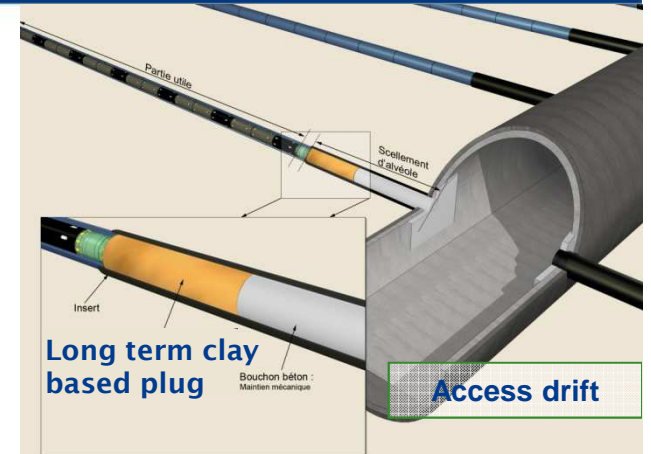



Reversibility

The reversibility conditions shall be set forth by a new Act before licensing.

- The reversibility of the repository should be granted, as a precaution, for at least 100 years (2006 Act).
- Reversibility shall not jeopardize safety.

Andra proposes an approach relying on:

- Technical measures to enhance the retrievability of waste packages.
- Stepwise decision-making to control the disposal process.

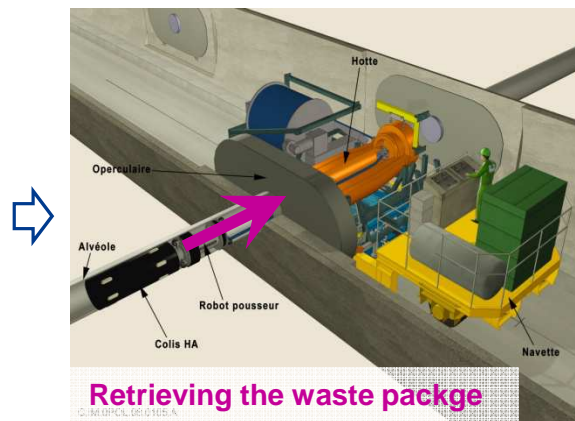
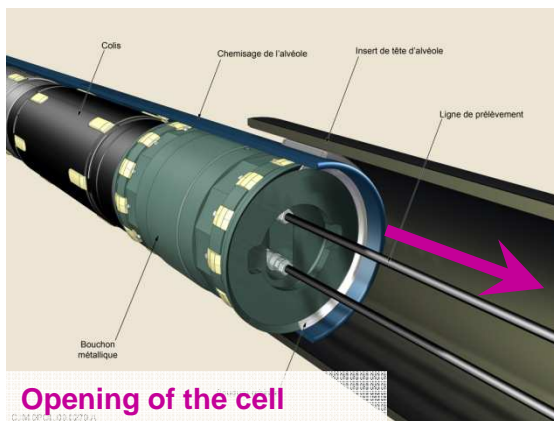

Reversibility principles

Andra proposal: reversibility conditions that do not endanger the safety of the repository and are realistic in terms of industrial exploitation



- Technical concepts that support the safe recovery of the waste packages
- Adaptable architecture, and progressive construction of the storage
- A gradual closing of the storage, which is designed to be closed permanently
- A transparent, coordinated, and editable closing schedule



Cigéo Project: industrial design phase under progress since 2011

- 20 years of R&D enabled Andra to issue detailed technical requirements, and location of the underground and surface facilities
- Planning of deliveries of the waste packages defined in close cooperation with the producers EDF, AREVA and CEA
- Cigéo design system prime-contractor selected (European call for tender)
- External infrastructures to be developed in the framework of the inter-district territorial scheme under the aegis of the State local representatives: staff housing, transportation, railway terminal, power and water supplies, etc.

- Three different designs have been produced by the prime-contractor teams
- The designs have been analyzed on technical, economic and safety sandpoints
- A first choice of the design has been done in the beginning of 2013
- A decicated review (associating experts, government representatives and waste producers) has evaluated the selected design in january and february 2013
- On this basis the prime and sub contractors will carry on additional developments and propose optimized designs

- Andra willing the public debate to be organized in the first semester of 2013
- Until the beginning of october 2012 a lot of uncertainties remained because of the possible overlapping of the debate on Cigéo with the national debate on the future french energy mix
- Finally in early october President Hollande indicated that the public debate on Cigéo will take place in 2013
- The ministry in charge of industry and environment has indicated that the debate will be organised in two 'sessions', the first one (mainly local) starting in may
- The dedicated commission has started its work

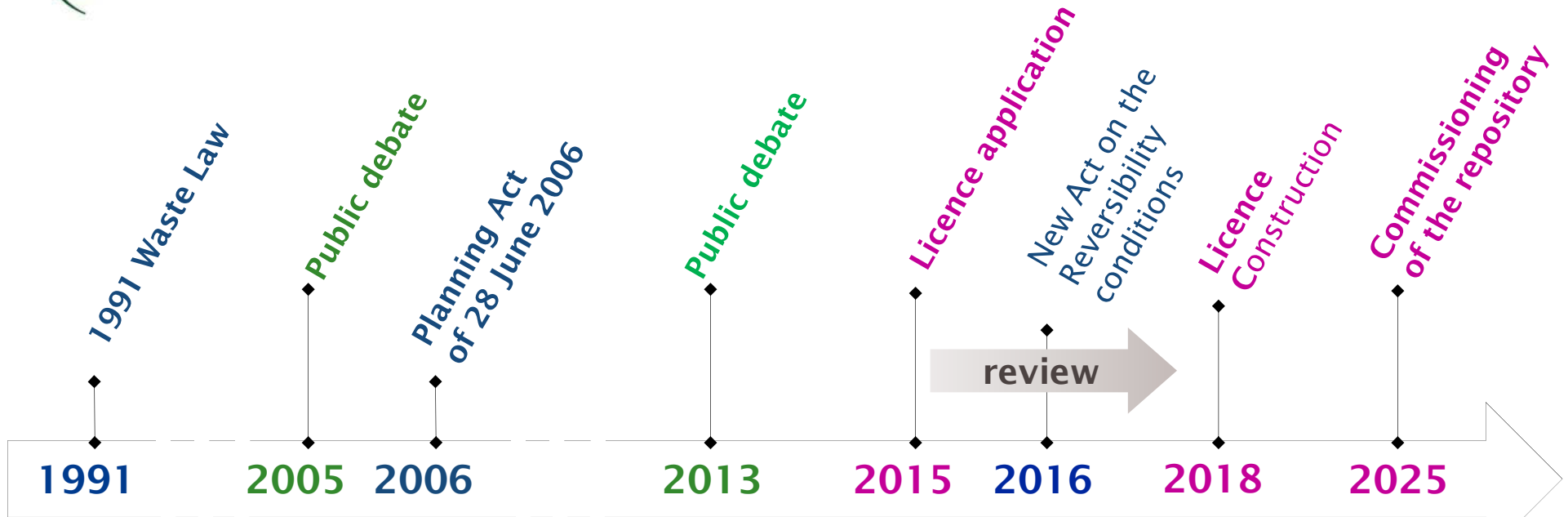

Dialogue between ANDRA and local stakeholders / CLIS

Inter-district scheme for territorial dvpt

Local involvement