



Off Site Source Recovery Project

John Zarling

Program Manager, Off-Site Source Recovery Project



Global Threat Reduction Initiative- NNSA NA-21 Mission

❑ **Mission:** Reduce and protect vulnerable nuclear and radiological material located at civilian sites worldwide

❑ **Goals:**

- ❑ Convert research reactors and isotope production facilities from HEU to LEU (permanent threat reduction)
- ❑ Remove and dispose of excess nuclear and radiological materials (permanent threat reduction)
- ❑ Protect high priority nuclear and radiological materials from theft and sabotage

MISSION

REDUCE AND PROTECT
VULNERABLE NUCLEAR
AND RADIOLOGICAL
MATERIAL LOCATED AT
CIVILIAN SITES
WORLDWIDE.

GOALS

1. CONVERT
2. REMOVE
3. PROTECT

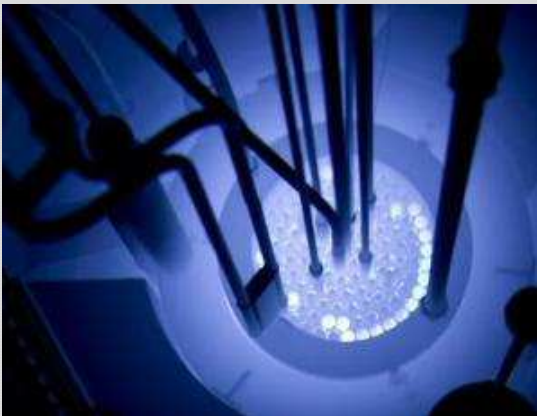



Off-Site Source Recovery Project (OSRP)

- Every year, thousands of sources become disused and unwanted in the United States.
- While secure storage is a temporary measure, the longer sources remain disused or unwanted the chances increase that they will become unsecured or abandoned. Thus, permanent disposal is essential.
- To carry out its mission, GTRI/OSRP has the authority to acquire disused sealed sources in the interest of national security or public health and safety.
- OSRP primarily recovers Cs-137, Co-60, Sr-90, Am-241, Pu-238, Pu-239
 - Every potential recovery is different and must be considered and prioritized. In coordination with NRC, OSRP has developed a recovery prioritization criteria based on threat reduction mission Criteria including activity, isotope, location, vulnerability
 - Different Types of Recoveries
 - Transuranics, Low activity (less than 370 GBq) beta/gamma sources without commercial disposal and High activity beta gamma devices
 - GTRI partners with CRCPD on the Source Collection and Threat Reduction (SCATR) project which works with state regulators and licensees to round up sources with commercial disposal pathways





GTRI/OSRP Recoveries

Basic Recovery Steps

Register via GTRI OSRP website osrp.lanl.gov

Outreach to those with registered sources and comprehensive update of database

Review prioritization criteria

GTRI, in coordination with NRC, has developed a recovery prioritization criteria based on threat reduction mission

Criteria includes activity, isotope, location, vulnerability

Consider logistical options and impediments

Availability of transport containers

Disposal options

Proximity to sites with scheduled recoveries (round-ups)

Select Best Path Forward

CRCPPD's SCATR Project

Small beta/gamma w/o commercial disposal

Self-ship

Transuranics

Large beta/gamma devices

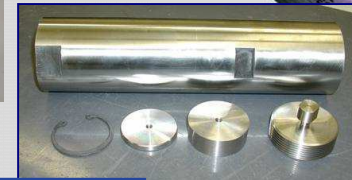

The screenshot shows the Los Alamos National Laboratory website. The main heading is 'Off-Site Source Recovery Project (OSRP) Sealed Sources Recovery | Los Alamos National Lab'. Below this, there is a navigation menu with 'Home', 'About Us', 'Operations', and 'OSRP in the News'. The main content area features a graphic with the text 'National Security through Source Recovery' and 'The OSRP recovers excess and unwanted radioactive sealed sources from around the globe as part of NNSA's Global Threat Reduction Initiative'. To the right of the graphic is a 'Sealed Sources Recovery Registration' form with fields for 'Site Info' (Facility Name, Department, Address Line 1, Address Line 2, City, State, Postal Code, Country (dropdown), Telephone) and 'Contact Info' (Email, Fax, Last Name). A sidebar on the left contains links for 'Register Sources', 'FAQs', 'Special Form Certificates', 'Operations & Recoveries', 'Applied Technologies', 'Storage Capabilities', 'Off-Site Material', 'Documents & Publications', and 'Useful Links'. At the bottom, there is a 'CONTACTS' section.

OSRP Sources Recovered

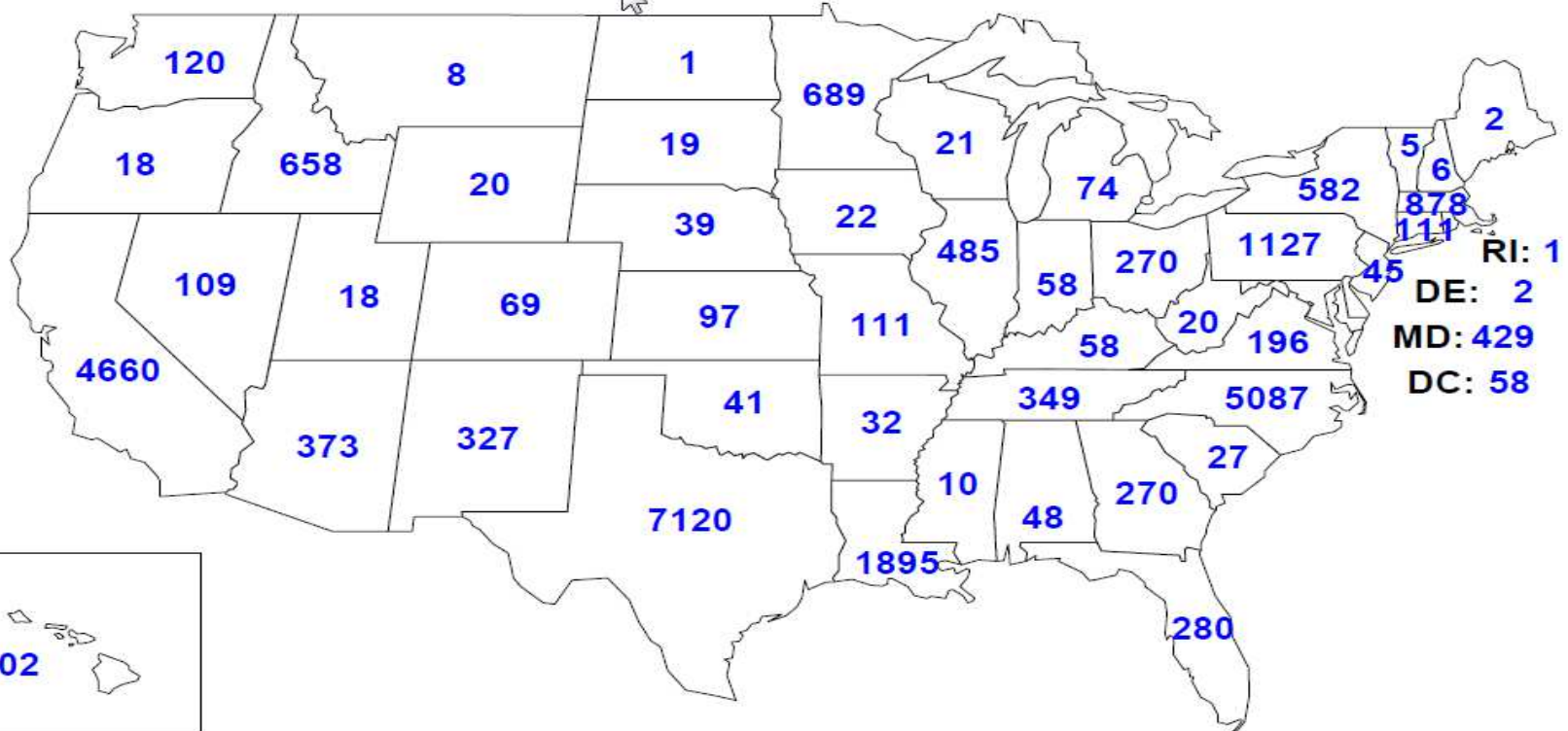

Total U.S. Sources: 27,050 (834,042 Ci) 3.08E4 TBq
Total International Sources: 2,442 (4,152 Ci) 154 TBq

As of December 18, 2012



GTRI-OSRP International Recoveries



Country	Number of Sources	Total Decayed Activity (TBq)
Argentina	19	1.3
Australia	207	1.9
Austria	1	.2
Brazil	1000	11
Canada	3	.1
Chile	431	.8
Denmark	11	1.6
Ecuador	36	.3
France	44	4.6
Germany	48	.5
India	23	2.3
Israel	7	1.1
Italy	11	44.5
Japan	1	.07
Peru	486	2.2
Singapore	1	.01
South Africa	69	.9
Sweden	9	.7
Switzerland	5	.6
Uruguay	30	78.1
Total	2,441	153



Sources Registered as Disused and Unwanted On GTRI/OSRP Database

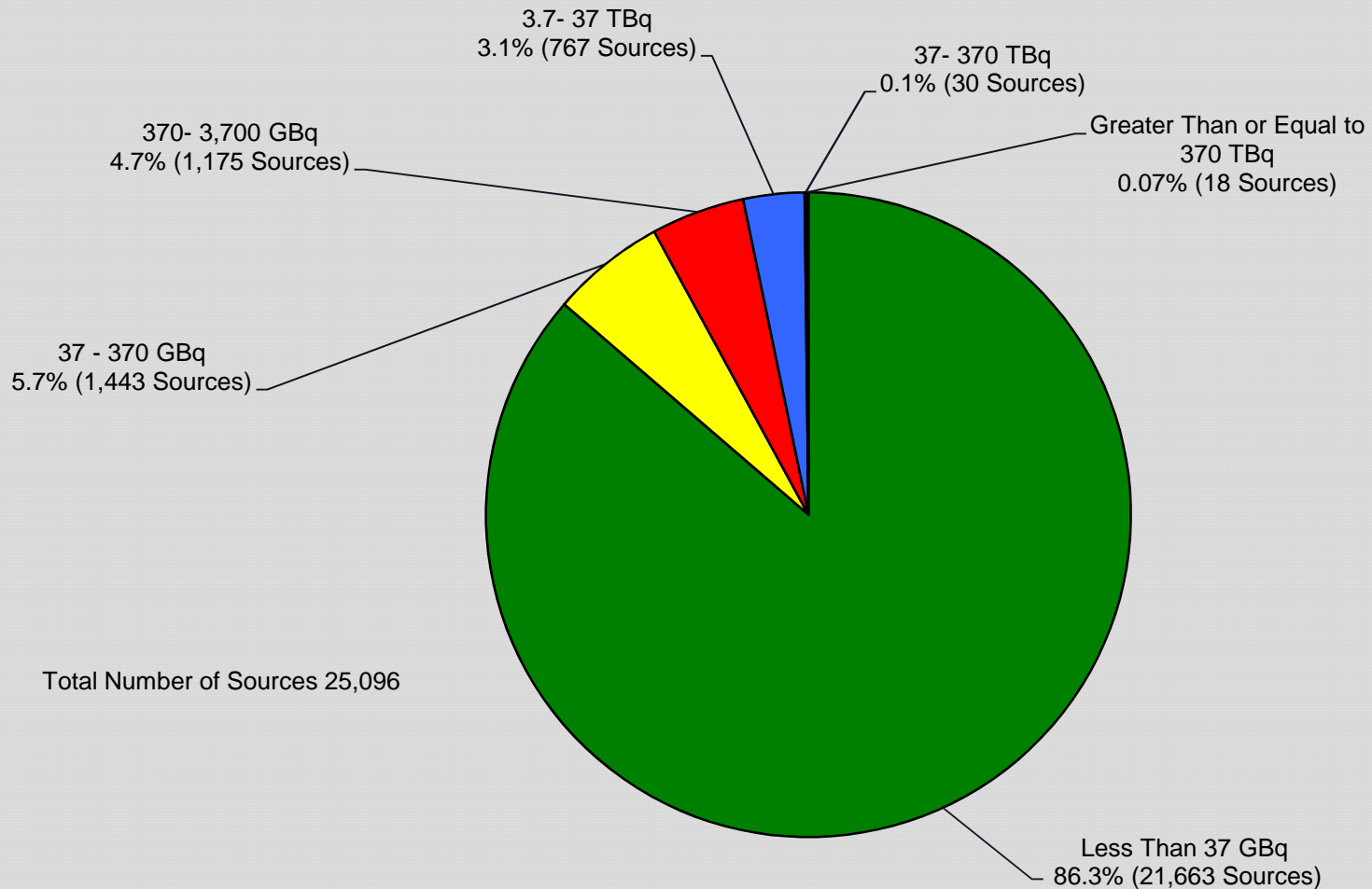



Decayed Activity of Disused and Unwanted On GTRI/OSRP Database

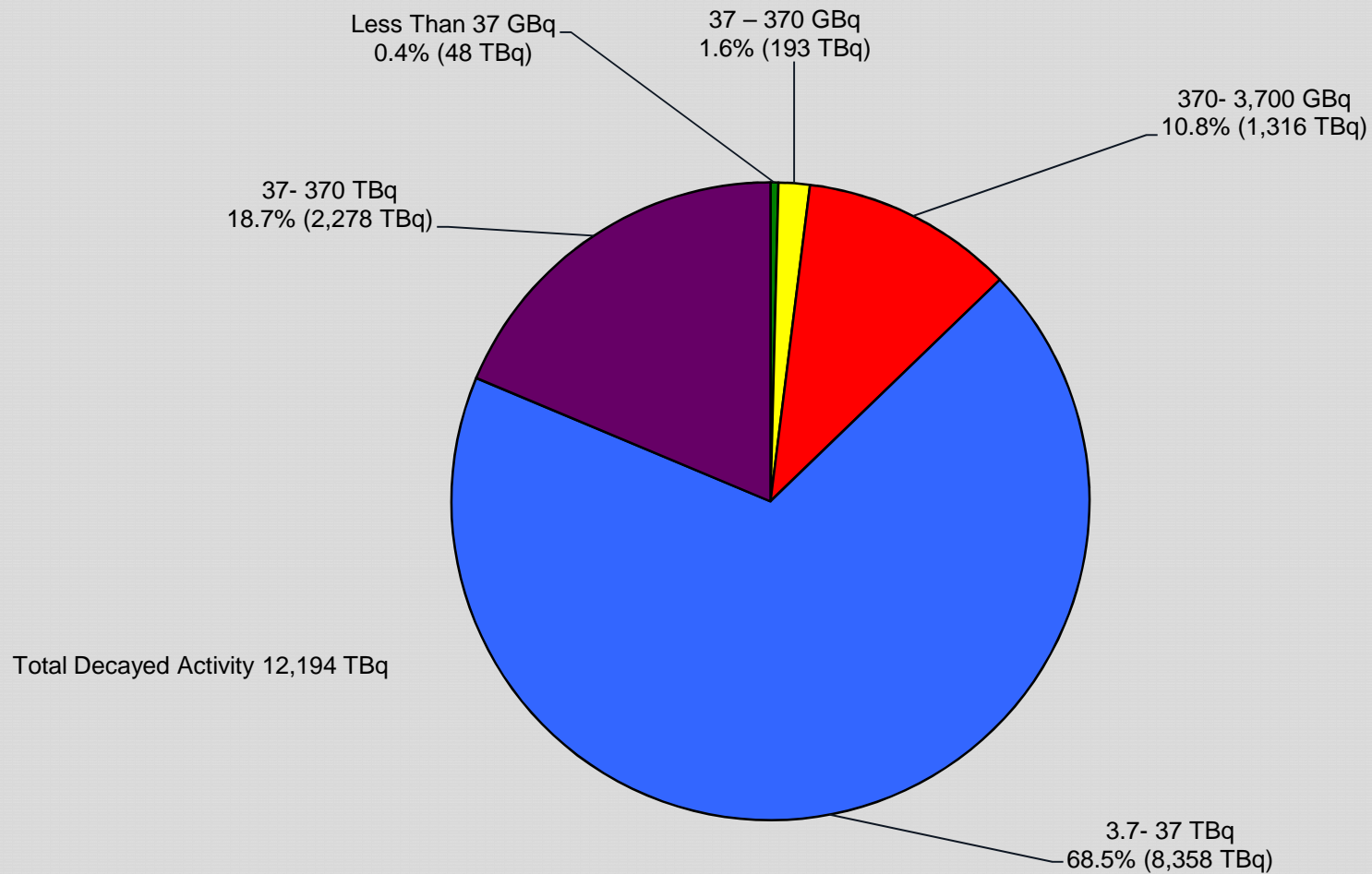



National Security and Disposal

- Radiation Source Protection and Security (RSPS) Task Force
 - Established pursuant to section 651(d) of the Energy Policy Act of 2005 (Public Law 109-58)
 - “[T]o evaluate and provide recommendations to the President and Congress relating to the security of radiation sources in the United States from potential terrorist threats.”
 - Includes membership from 14 Federal agencies and 2 State organizations
 - Reports to Congress and the President on progress in sealed source security every four years
 - Next Task Force Report due in 2014
- 2010 Radiation RSPS Task Force Report
 - “By far the most significant challenge identified is access to disposal for disused radioactive sources.” (p.iii)
 - “Continued coordinated effort is needed to make sure that comprehensive, sustainable disposal pathways for all disused sealed sources are developed in the interest of national security.” (p.iii)
 - “2010 Recommendation 4: The Task Force recommends that the U.S. Government, regional compacts, and States continue to evaluate disposal options for disused radioactive sources, including options for handling a potentially large number of disused cesium chloride sources that may be replaced once viable alternatives are available.” (p.37)



Key Sealed Source Disposal Challenges

- There are two primary challenges:
 1. Lack of commercial disposal options for high-activity beta/gamma sources (primarily cobalt-60, cesium-137 and strontium-90)
 2. Lack of near-term disposal capability for US-licensed sealed sources containing foreign-origin transuranic source material



LANL Special Form Capsule

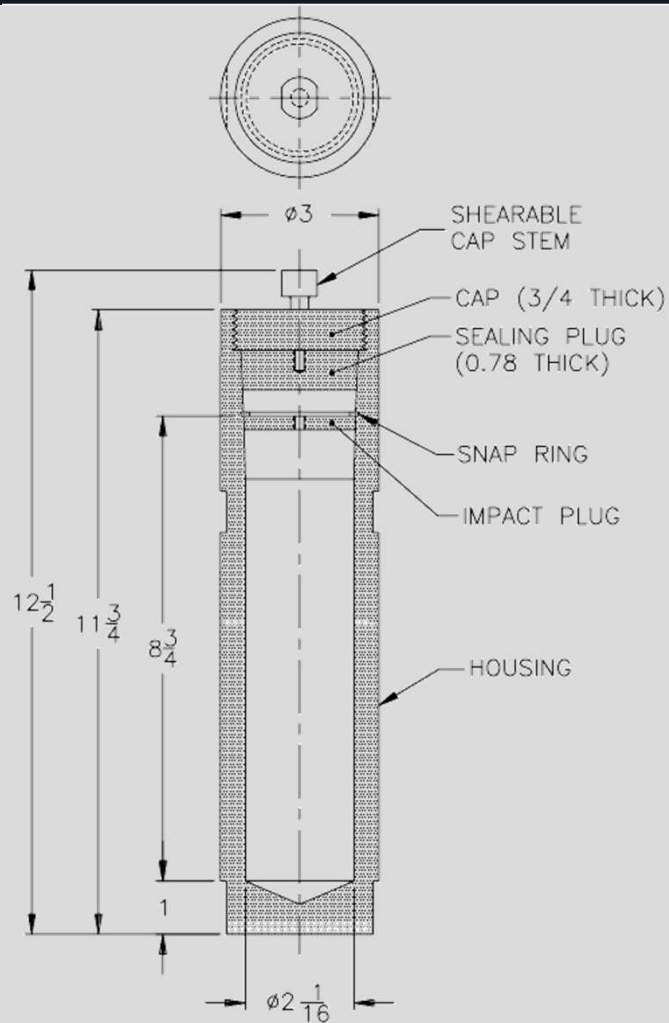

- Solves special form problem
- Useful for consolidation
- Useful for storage and disposition
- Solves some safety and security issues
- Allows Type A shipment



Type A(F) Packaging: S300 POC

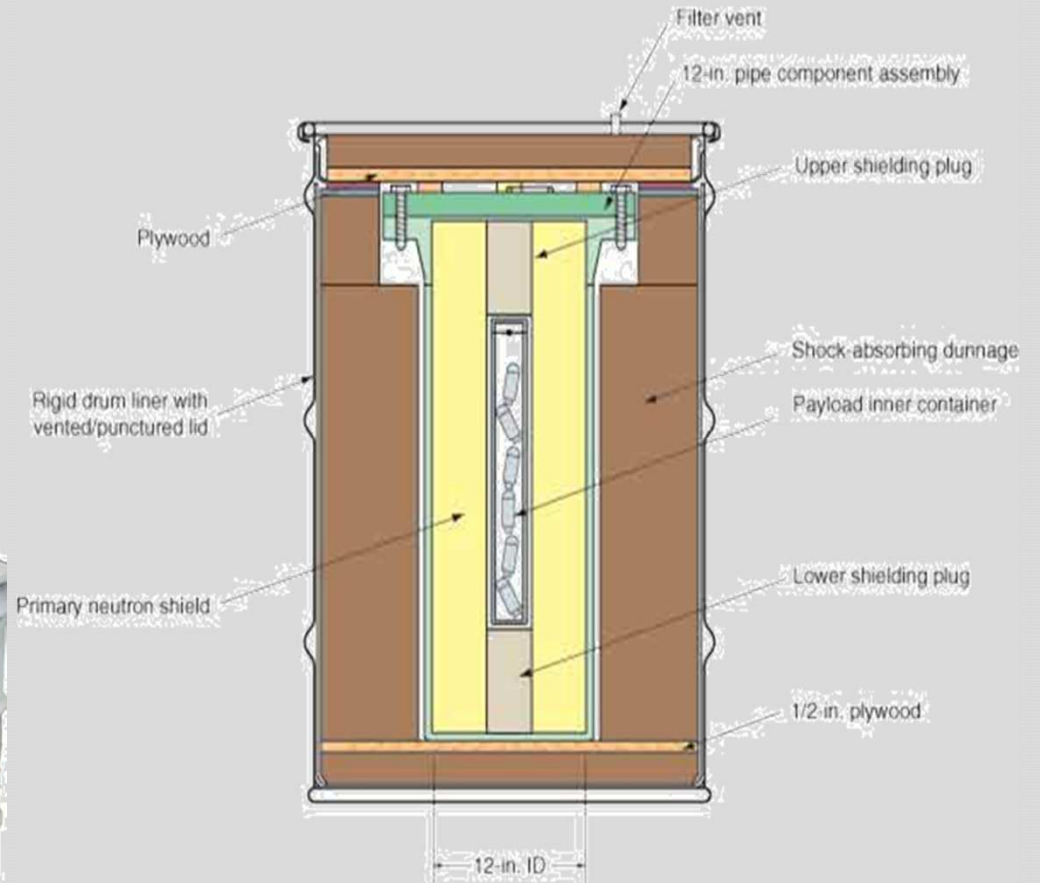

Security Technology Installed on the OSRP Truck

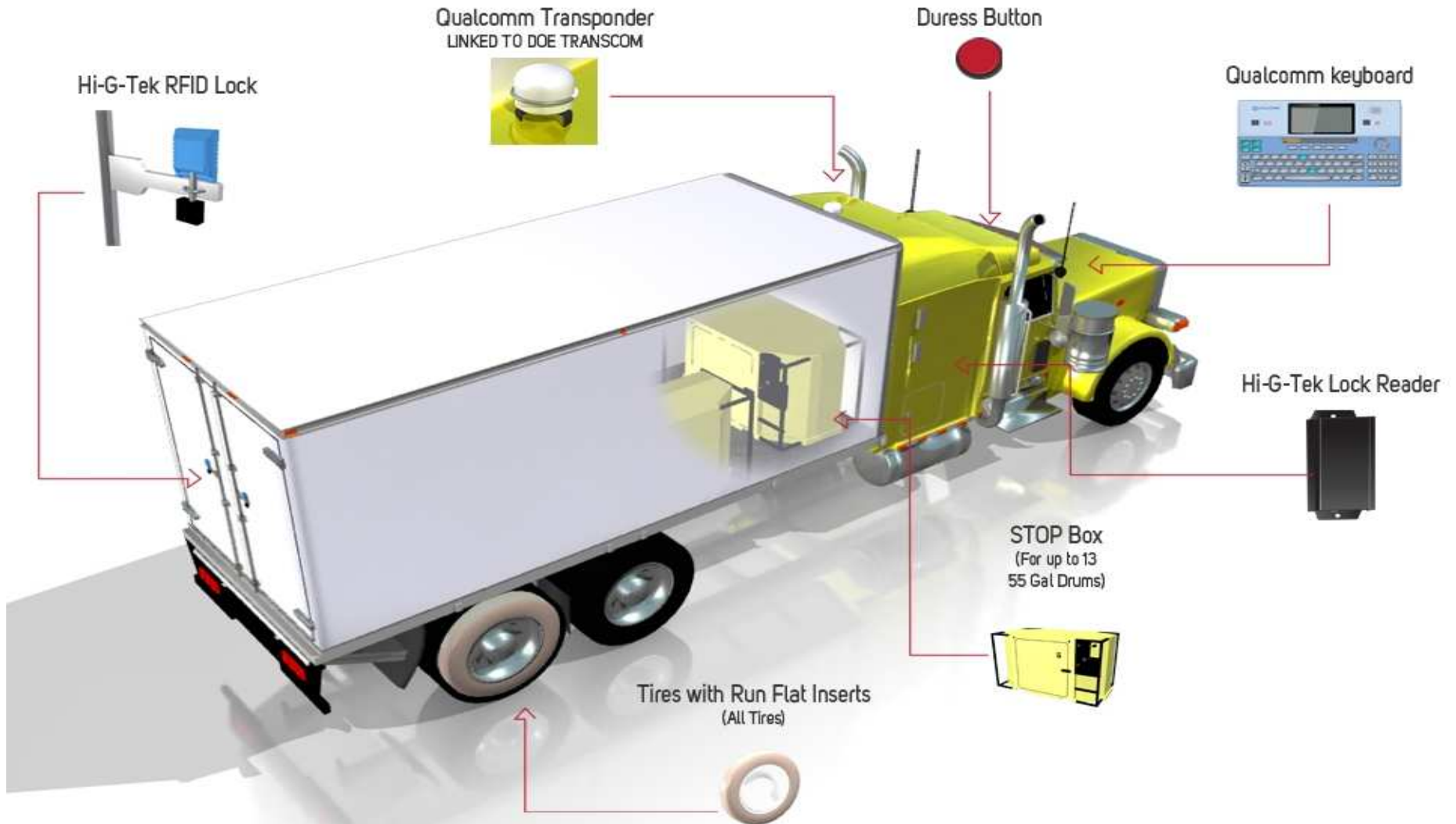



Type B Container Effort

- ◆ 2010 Radiation RSPS Task Force Report
 - ◆ **2010 Recommendation 8:** The Task Force recommends that the U.S. Government enhance support of short-term and long-term research and development of certified Type B containers for use in domestic and international source recovery efforts. (p. 38)



Issues

Regulatory Changes

- Many Type B packages were designed several decades ago and do not meet new international standards. In a January 2004 rulemaking, NRC adopted revised regulations to harmonize with the 1996 edition of the IAEA regulations.
 - Packages that match IAEA regulations only fit a small number of devices (<10%) and are expensive to use due to limited availability.
- Type B packages did not have to meet the new design standards until October 1, 2008. After this date, many of the existing Type B packages could no longer be used.
- In the United States, the Department of Transportation (DOT) issued special permits to companies for continued issue of noncompliant DOT Specification 20WC and 6M containers. The last one expired June 2012.
- Because industry needs Type B packages to ship new devices, it was believed that industry would develop new packages that would meet the new design standards.
- By 2009, it was clear industry was not developing new general-use packages but rather relying on device-specific packages certified to accommodate only those devices they were currently distributing.



Issues Cont.

- DOT has rejected all requests for special permit extensions for the DOT Specification 20WC containers.
- Most GTRI/OSRP recoveries (~80%) involving Type B quantities of Cs-137 or Co-60 have been completed using the expired DOT Specification 20WC containers that are no longer available for use to ship.
- GTRI/OSRP has a backlog of about 130 excess and unwanted sources/devices that must be shipped in Type B containers.
- Type B packages that meet the new standards are expensive to lease (\$200,000 for-two weeks use of the GE 2000) or buy (\$2.5M for the 10-160B), and are available only in limited quantities or are in high demand, making availability uncertain.
- Other limitations include weight or volume restrictions, payload activity limits too low, restrictions on form of materials



435 B Design

- External construction based on previously certified container
- Design parameters:
 - IAEA LTSS – custom lodgement
 - Shielded devices w/ Cs-137 or Co-60 – internal container – max weight 1,590 Kg
 - LTSS Cs, Sr, Ir, Se Ra, Am Pu and small neutron sources
 - Approx 480 TBq Co-60, 200 W
 - Leak-tight – NCT and HAC
 - Transport by truck, rail, ship, air
 - External dimensions 209 cm H x 179 cm OD
 - Internal Cavity 152 cm H x 110 cm in ID
 - Empty weight 2,225 Kg, total weight 4,535 Kg

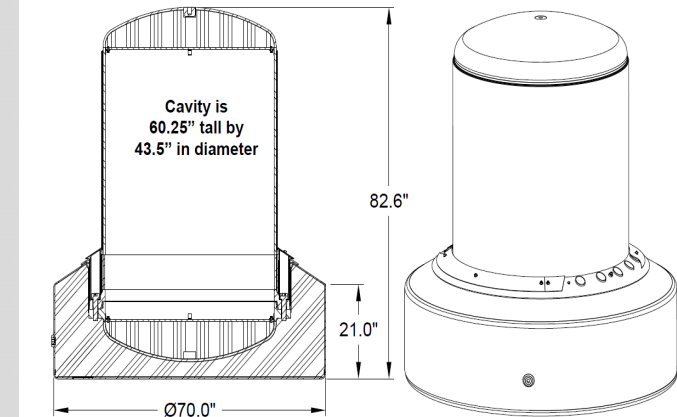

22

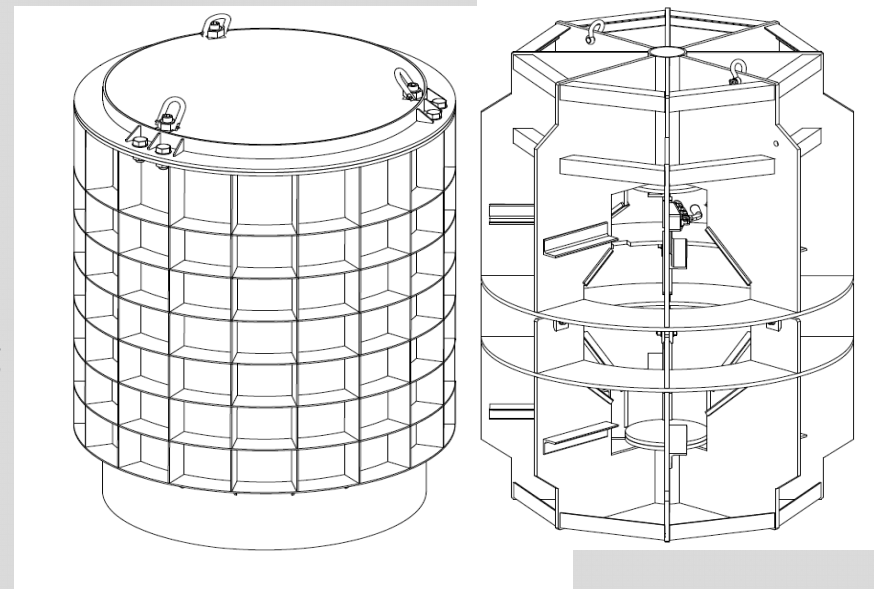

Slide 17

22

Is it alright to share design drawings of container still not approved for use?

219257, 1/23/2013



380 B Design

- Design parameters:
 - Payload weight 4,535 Kg
 - Co, Cs, Sr, Ir, Ra Am Pu and Depleted Uranium
 - Approximately 275 TBq Co-60
 - Leak tight – NCT and HAC
 - Transport by truck, rail, ship, air
 - External dimensions 330 cm H x 254 cm OD
 - Internal Cavity 162 cm H x 113 cm ID
 - Empty weight 35,835 Kg

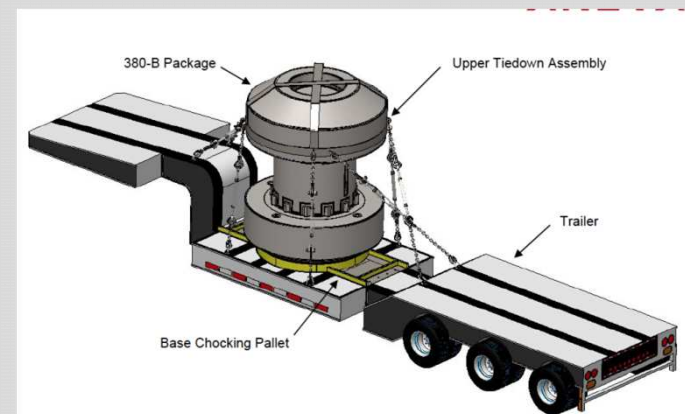
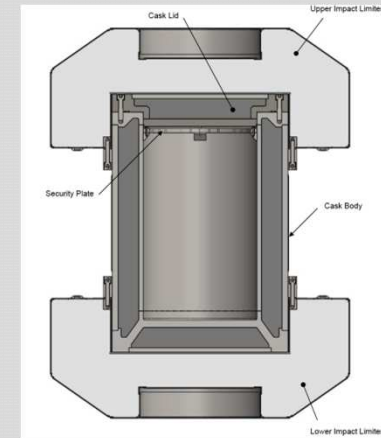
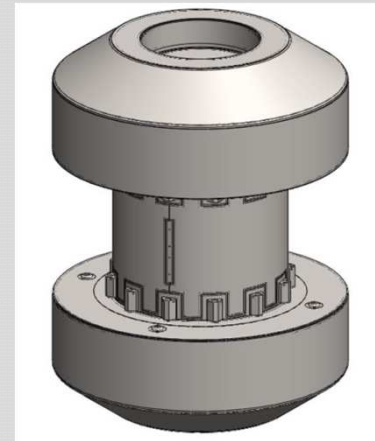



◆ Questions