

## **PaR Tensile Truss for Nuclear Decontamination and Decommissioning – 12467**

Gary R. Doebler, Project Manager, PaR Systems Inc.  
707 County Road E West, Shoreview, MN 55126

### **ABSTRACT**

Remote robotics and manipulators are commonly used in nuclear decontamination and decommissioning (D&D) processes. D&D robots are often deployed using rigid telescoping masts in order to apply and counteract side loads. However, for very long vertical reaches (15 meters or longer) and high lift capacities, a telescopic is usually not practical due to the large cross section and weight required to make the mast stiff and resist seismic forces. For those long vertical travel applications, PaR Systems has recently developed the Tensile Truss, a rigid, hoist-driven “structure” that employs six independent wire rope hoists to achieve long vertical reaches. Like a mast, the Tensile Truss is typically attached to a bridge-mounted trolley and is used as a platform for robotic manipulators and other remotely operated tools.

### **INTRODUCTION**

The Tensile Truss was originally developed by Dr. James Albus for the U.S. National Institute of Standards and Technology Agency (NIST) in the early 1990’s and was called the RoboCrane®. PaR Systems has been licensed through NIST to use this technology for its Tensile Truss applications. Based on the Stewart platform parallel linkage manipulator, the Tensile Truss is like an inverted Stewart platform that uses wire ropes as the links and winches or hoists as the actuators. A lower triangular platform is suspended from the wire ropes and the six independent hoists mounted to the upper triangular platform. The control system precisely maintains tension in all six ropes, keeping the lower platform kinematically constrained. As long as all six ropes remain in tension the system will behave like a rigid truss structure. Therefore, weight on the lower platform increases the rigidity of the structure, making the Tensile Truss ideal for deploying heavy tools.

### **DISCUSSION**

The degree of stiffness in the Tensile Truss is based on tension in the ropes, angles of the ropes between the upper and lower platforms and the spring rate of the ropes. Therefore, the required stiffness can be engineered based on these parameters. The stiffness varies with the elevation of the lower platform; the higher the elevation, the greater the angles in the ropes. See Fig. 1, showing the Tensile Truss in extended and retracted positions. The angles also vary by the difference in the sizes of the upper and lower platforms.

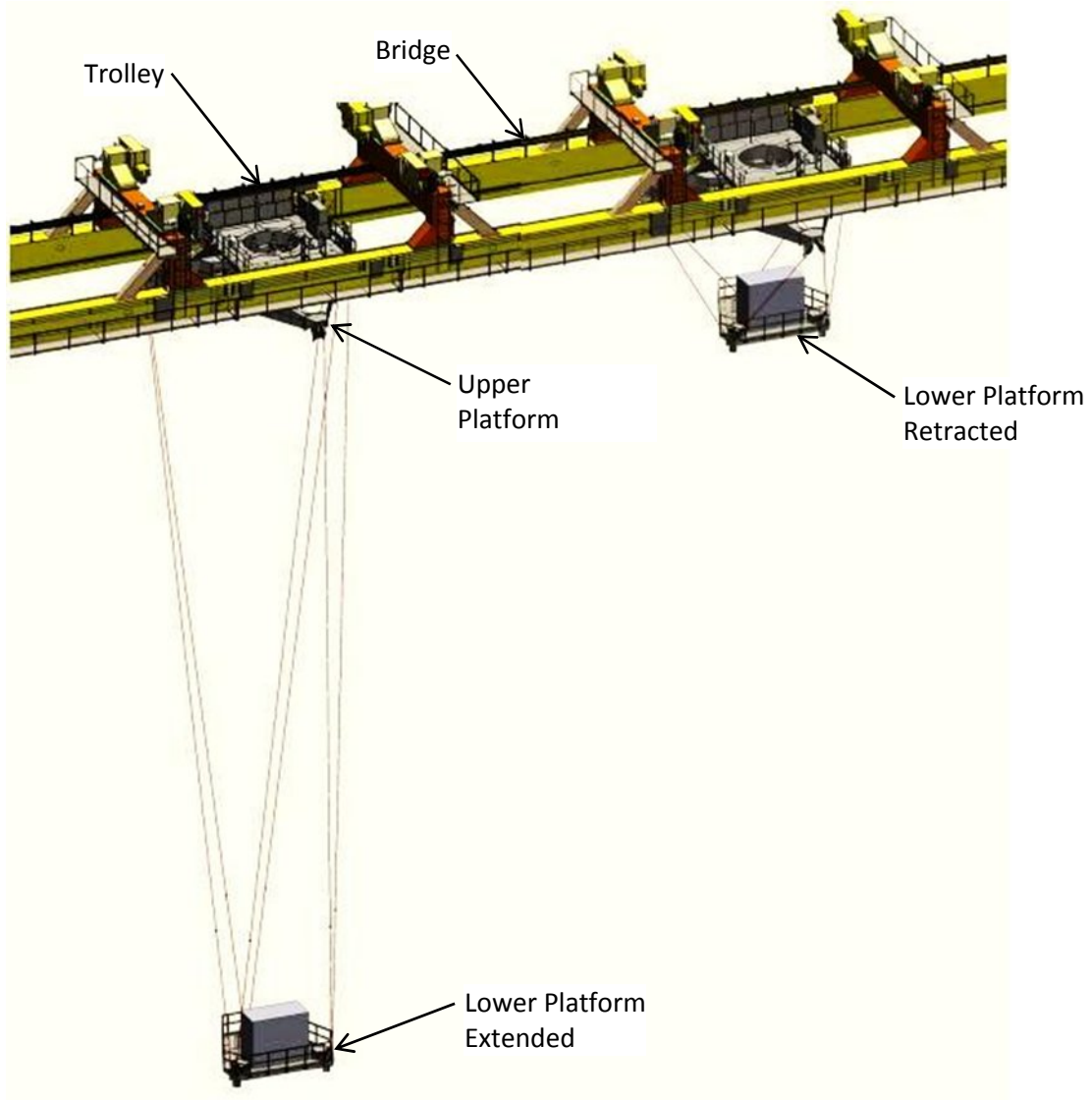

Fig. 1: Tensile Truss Shown Extended and Retracted

### Safety and Recovery

In most D&D applications, safety of operation and recovery are primary concerns. Long travel masts are typically driven by one or two hoists, whereas the Tensile Truss is inherently safer due to the redundancy of the six hoists. If one or two ropes or hoisting mechanisms should fail, the Tensile Truss can be recovered using the remaining hoists. PaR's Tensile Truss design measures the tension in each of the six hoist ropes independently, so excessive side loads and overloading can be detected. If the design side load is exceeded (in a collision or seismic event), one or more wire ropes simply go slack without damaging the system. This type of horizontal overloading on a telescoping mast could result in deformation of the tube sections, making retraction and recovery difficult if not impossible. Another significant advantage of the

Tensile Truss is in decontamination of the machine prior to maintenance or repair activities. There is far less surface area than a telescoping mast and it does not have the overlapping sections of a mast that are inaccessible and trap contaminants.

### **Design Analysis**

In the course of developing the Tensile Truss for heavy D&D applications, PaR Systems has done extensive engineering analyses. Two independent analyses were performed and verified by a static scale model. Detailed calculations using a closed form theoretical model and a finite element analysis (FEA) were performed and verified by the results of the scale model. Deflection tests and “break-away” tests (the point at which one or ropes go slack) were performed by applying varying side loads. The model deflection values were within 22 percent of the theoretical calculated deflections and model break-away force was within 13 percent.

### **Optional Design Features**

For some applications where clearances with walls or other obstructions need to be considered, a slewing (rotate) can be provide between the trolley and the upper platform of the Tensile Truss. In this configuration the entire Tensile Truss can be rotated to avoid contacting the wire ropes with walls or obstructions. Generally, a lower rotating axis is incorporated on the underside of the lower platform for positioning tools such as demolition arms, grapples, dual hydraulic manipulator systems or cutting tools. In most cases camera systems are used to remotely position the tools.

Since the stiffness of the Tensile Truss is particularly dependent on the angles of the ropes, the upper platform can be designed with telescoping boom arms to increase the angles, effectively increasing the size of the upper triangle. This feature would be used where increased stiffness is required for some operation but a smaller upper platform may be needed at times to avoid clashes with the wire ropes. This could also be used to change the natural frequency of the structure where tools are used that could excite the Tensile Truss.

Where extended vertical travel is needed the Tensile Truss can be increased and used as a crane for heavy lifting. At these extended lower elevations, the stiffness is decreased, but not the lifting capacity. This capability could also be used for machine maintenance or tooling changes at floor levels.

Since the six hoisting mechanisms are independently controlled, lower platform can be positioned independently of the upper platform is six degrees of freedom: X, Y and Z and yaw, pitch and roll. This motion, sometimes referred to as “flying” or “floating” is controlled by an operator via joysticks and adds increased flexibility to the tools by allowing for finer position control and closer approaches to walls or obstructions. This feature is used on a NIST-developed robotic paint stripping system used on U.S Air Force C-130’s, drastically reducing paint stripping time and increasing operator safety.

## Chernobyl MTP

PaR Systems is currently under contract to provide a very large Tensile Truss for the Chernobyl nuclear power plant decommissioning effort in Ukraine (see Fig. 2). The Chernobyl machine, called the Mobile Tool Platform (MTP) will be mounted to a bridge and trolley (as shown in Fig. 2) will have 35m (115 ft.) of vertical working travel and 66m (216 ft.) total travel for maintenance access at floor level. At full 35m extension will be able to withstand 1.5 tonnes (1.7 tons) of horizontal side load. The MTP will deploy a large hydraulic demolition arm that will be fitted with drills, demolition jaws, shears and a vacuum system. The MTP will be fitted with six 12 ton hoists. The total lift capacity (lower platform, equipment and payload) is 32 tonnes (35 tons).

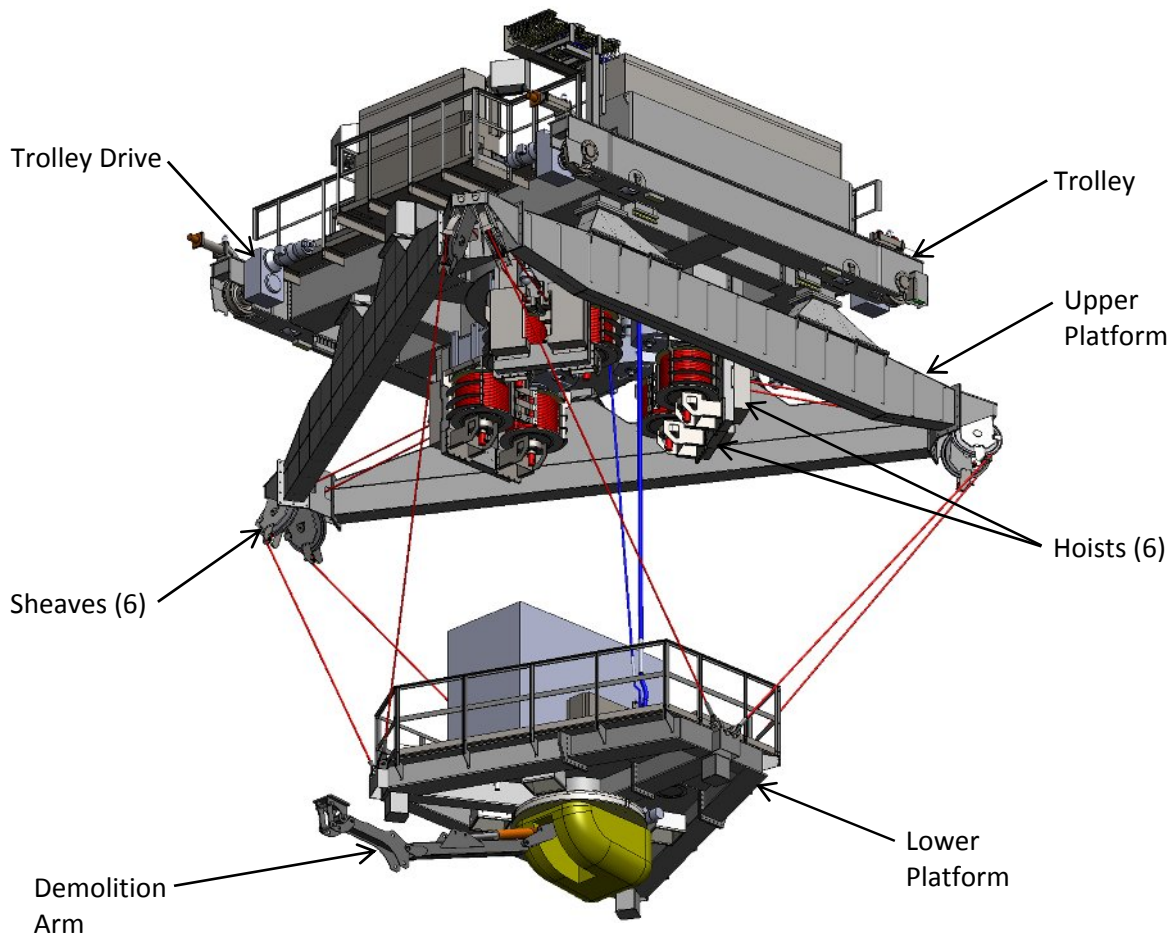

Fig. 2: Chernobyl MTP with Demolition Arm

## MTP Control System

The MTP control system consists of three major subsystems: a safety PLC system, a wireless communications system and the motor drive system. See Fig. 3 for a diagram of the MTP control system architecture.

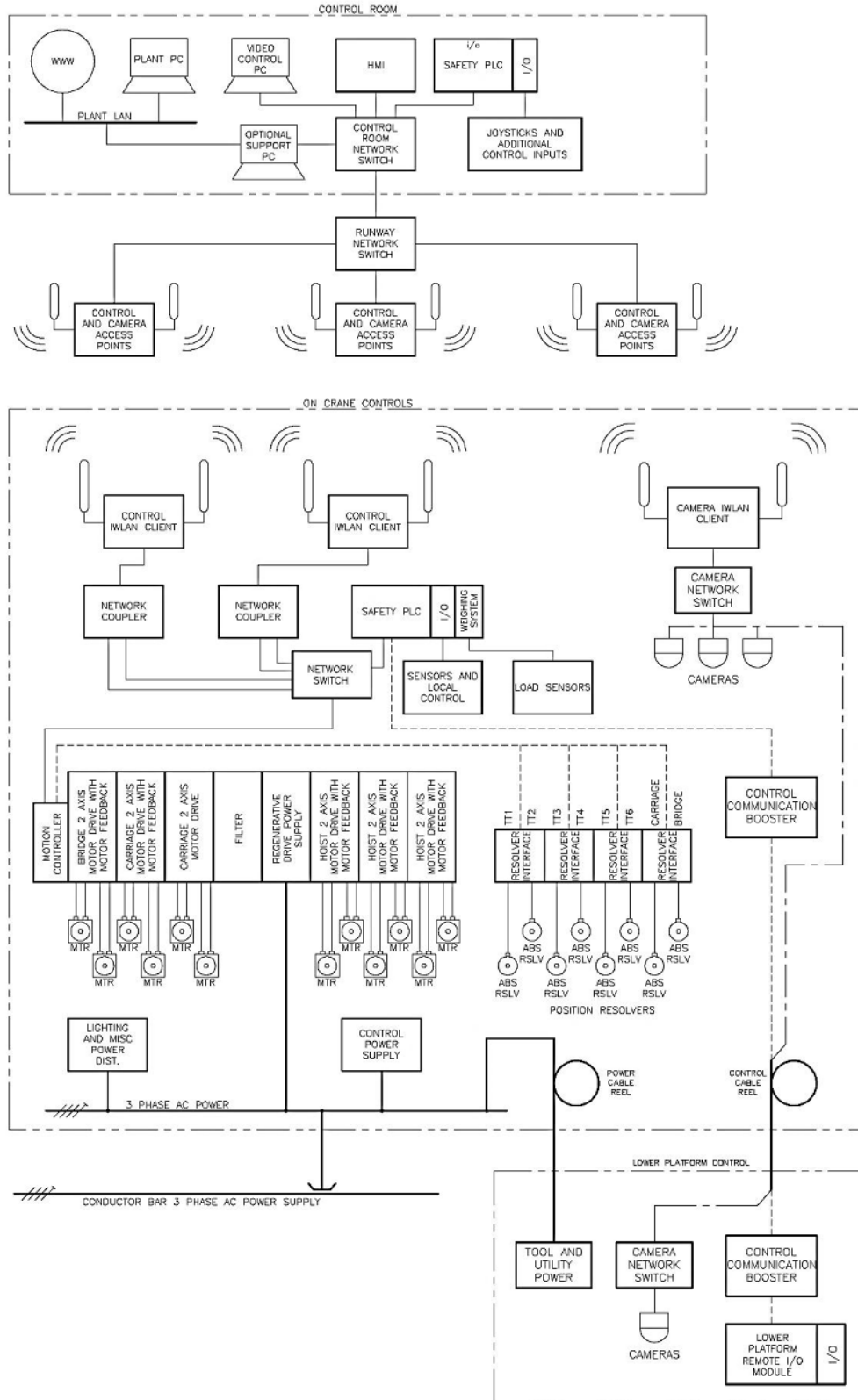

Fig. 3: MTP Control System Architecture

One safety PLC is stationary and another is located on-board the crane. The stationary PLC is used for the interface with the operator controls and Human-Machine Interface (HMI) display and sends the operator command signals to the on-board PLC. The on-board PLC receives the operator commands via the wireless communications system and executes the commands, monitors sensors and feedback devices, performs interlock and safety functions and provides motion commands to the motor drives. On-board cameras are also used and the video signals are sent back to the operator control station via the wireless system.

The wireless communication system is based on the IEEE 802.11 global wireless standard. The industrial wireless LAN (IWLAN) operates on the IEEE 802.11 “a” frequency range at 5 GHz. The network provides redundancy and availability in highly challenging environments by using multiple stationary access points. As the signal strength varies between access points and the client with increased distance or interference with obstacles the client modules automatically switch to a stronger connection from available access points. This switching takes place within milliseconds, so normal operation is not affected. In addition to the multiple access points, each piece of mobile equipment uses redundant client modules to maintain availability and recoverability in the event of a hardware failure. Point Coordination Function (PCF) technology permits cyclic data traffic over several wirelessly linked access points and clients simultaneously, ensuring reliability of data communication. Control and video signals are transmitted over the same wireless network.

The motor drive system operates the MTP motors using vector drive technology for the hoist motors. Hoist, cross travel and long travel motions all have absolute position feedback devices to ensure the position of the MTP is known at all times and to prevent skewing on cross and long travel motions. This position data allows for the option of semi-automated operation of the MTP.

Each of the MTP hoisting mechanisms has a load cell device in the reeving system, which measured the load on each wire rope. These load cell signals are processed by the remotely mounted PLC and are used in conjunction with the hoist motor torque information in protecting for hoist overload. The signals are also used by the PLC to determine external forces applied to the lower platform; vertical and horizontal as well as moment loading. The load cell information is also sent back to the stationary PLC and is displayed at the operator station.

Control signals to the lower platform are communicated through hard wired connections from a cable reel mounted on the upper platform. These signals support the rotate axis on the lower platform and the wide variety of tools and vacuum system deployed by the MTP. Power is also provided via a second cable reel with capacities reaching 150kw for the high demand hydraulic and vacuum systems.

### **MTP Scale Model**

Because the Chernobyl MTP system is so large, it cannot be erected in PaR’s factory. A one-quarter scale model with a fully functional control system has been constructed in PaR’s factory

and is currently being used for controls and software development and testing. The scale factor chosen was the maximum size that would fit in the available space. The model is being used to prove out predictive software and development of the control system for the six hoist arrangement. The model, shown in Fig. 4 below, was kept as architecturally close to the full size MTP as possible in order to apply the results of the development activities to the full size MTP. The system contains all of the features of the full scale system and will be retained at PaR Systems after testing for continued development and general use in the factory.



Fig. 4: MTP Scale Model at PaR Factory

## CONCLUSION

For suspended, rigid deployment of D&D tools with very long vertical reaches, the Tensile Truss can be a better alternative than a telescoping mast. Masts have length limitations that can

make them impractical or unworkable as lengths increase. The Tensile Truss also has the added benefits of increased safety, ease of decontamination, superior stiffness and ability to withstand excessive side loading. A Tensile Truss system is currently being considered for D&D operations and spent fuel recovery at the Fukushima Daiichi Nuclear Power Plant in Japan. This system will deploy interchangeable tools such as underwater hydraulic manipulators, hydraulic shears and crushers, grippers and fuel grapples.

## REFERENCES

1. R. Bostelman, A. Jacoff, N. Dagalakis, J. Albus, "RCS-Based Robo-Crane Integration ," *Intelligent Systems Division National Institute of Standards and Technology*
2. R. Owen, M. Guterman, G. Doebler, "Report; Chernobyl Tensile Truss Mobile Tool Platform", *Chernobyl New Safe Confinement*, October 17, 2008