

## **THORIUM FUEL OPTIONS FOR SUSTAINED TRANSURANIC BURNING IN PRESSURIZED WATER REACTORS - 12381**

Fariz Abdul Rahman\*, Fausto Franceschini\*\*, Michael Wenner\*\*, John C. Lee\*

\*University of Michigan, Ann Arbor, MI, USA

\*\*Westinghouse Electric Company LLC, Cranberry Township, PA, USA

### **ABSTRACT**

As described in companion papers, Westinghouse is proposing the adoption of a thorium-based fuel cycle to burn the transuranics (TRU) contained in the current Used Nuclear Fuel (UNF) and transition towards a less radiotoxic high level waste. A combination of both light water reactors (LWR) and fast reactors (FR) is envisaged for the task, with the emphasis initially posed on their TRU burning capability and eventually to their self-sufficiency. Given the many technical challenges and development times related to the deployment of TRU burners fast reactors, an interim solution making best use of the current resources to initiate burning the legacy TRU inventory while developing and testing some technologies of later use is desirable. In this perspective, a portion of the LWR fleet can be used to start burning the legacy TRUs using Th-based fuels compatible with the current plants and operational features. This analysis focuses on a typical 4-loop PWR, with 17x17 fuel assembly design and TRUs (or Pu) admixed with Th (similar to U-MOX fuel, but with Th instead of U). Global calculations of the core were represented with unit assembly simulations using the Linear Reactivity Model (LRM). Several assembly configurations have been developed to offer two options that can be attractive during the TRU transmutation campaign: maximization of the TRU transmutation rate and capability for TRU multi-recycling, to extend the option of TRU recycling in LWR until the FR is available. Homogeneous as well as heterogeneous assembly configurations have been developed with various recycling schemes (Pu recycle, TRU recycle, TRU and in-bred U recycle etc.). Oxide as well as nitride fuels have been examined. This enabled an assessment of the potential for burning and multi-recycling TRU in a Th-based fuel PWR to compare against other more typical alternatives (U-MOX and variations thereof). Results will be shown indicating that Th-based PWR fuel is a promising option to multi-recycle and burn TRU in a thermal spectrum, while satisfying top-level operational and safety constraints.

### **INTRODUCTION**

In our approach to selecting an effective fuel cycle solution driven by waste management [1], we had proposed the Th fuel cycle given the potential for a low-actinide waste radiotoxicity and the capability to burn the high-radiotoxicity legacy TRU stock. Due to the advantages of a hard spectrum on the TRU transmutation, fast reactors provide the most effective environment for burning TRU. A Th-based FR has the potential for indefinite recycle until complete TRU burning, while offering a flexible breeding ratio to sustain a long term closed Th cycle with minimal TRU content, as described in companion papers [2]. However, due to the long time anticipated for the deployment of a fast reactor fleet, an interim solution that initiates the burning of the legacy TRU making use of the current LWR is proposed in this paper.

We have focused our efforts on a typical 4-loop PWR with 17x17 fuel assemblies, with fuel pellets containing TRUs (or Pu) as the seed fissile component and Th as the fertile material. Homogeneous and heterogeneous assembly configurations have been developed to cope with varying objectives and required capabilities which could occur during a TRU transmutation campaign. For instance, homogeneous configurations of Th-Pu (or Th-TRU) pins can achieve a high TRU transmutation rate with relatively simple intra-assembly loading pattern. Except for using Th instead of U as the Pu carrier, this option has similar performance, and constraints, of regular MOX fuel. Due to the degradation of the Pu fissile quality, this option is not suitable for multi-recycle of the Pu (or TRU) as it quickly leads to excessive TRU loading in the recycled fuel, with issues on safety, reactor control, fuel handling etc. On the other hand, heterogeneous assembly configurations, with Th-TRU and Th-U233 pins, especially with higher-density N-15-enriched nitride fuel, provide the framework for TRU multi-recycling: the U233 internal breeding can be enhanced thereby reducing the TRU loading and degradation, and slowing its increase in the multi-recycled fuel. In addition to the higher breeding potential, nitride fuel has better thermal properties, which allows increasing the rod size with further benefits to the breeding performance. An additional benefit of a heterogeneous assembly configuration is that it can reduce interface effects between core assemblies at the cost of more complicated manufacturing and higher production costs.

## METHODOLOGY

Simulations were performed using the lattice physics code, CASMO [8], for a typical 4-loop Westinghouse PWR with the following characteristics:

- 3,411 MWt
- 1.5-year cycle
- 90% capacity factor
- 193 assembly core
- 17×17 assembly lattice
- Three-batch fuel management
- 5-year cooling before recycle
- $k=1.03$  at end-of-reactivity-life to account for leakage

The simulations have been performed in 2D single-assembly geometry, using the LRM [3] to infer the behavior of a batch of fuel for the 4-loop PWR under consideration, assuming a 3,411 MWt reactor power. Accordingly, the mass flows and actinide contents presented in this paper are tabulated as kg per batch per GWt-yr, where each batch is assumed to be composed of 64 fuel assemblies and each cycle consists of 4.5 effective full power years (EFPY) of irradiation time and a total 5 years of decay to account for cooling, separation, recycle and manufacturing before the next irradiation cycle starts. The actinide balances in the plots are given as kg per batch as a function of the number of recycles, i.e. they differ from the amounts in the tables by a normalization factor (the energy generated by the batch per cycle, i.e. ~5.1 GWt-yr).

The flowchart in Figure 1 describes the general recycling strategy employed in our simulations. At the end of each cycle, the end-of-cycle (EOC) inventories from the Th-based PWR are reprocessed after a 5-year cooling period and recycled as desired. More fissile isotopes are added to sustain the cycle length. The Pu or TRU feed is obtained from a typical PWR Used Nuclear Fuel (UNF) with 50 MWd/kgHM burnup after 10 years of cooling time. All fission products (FP) are sent to the repository and it is assumed that 99.9% of the heavy metals (HM) are recovered during reprocessing.

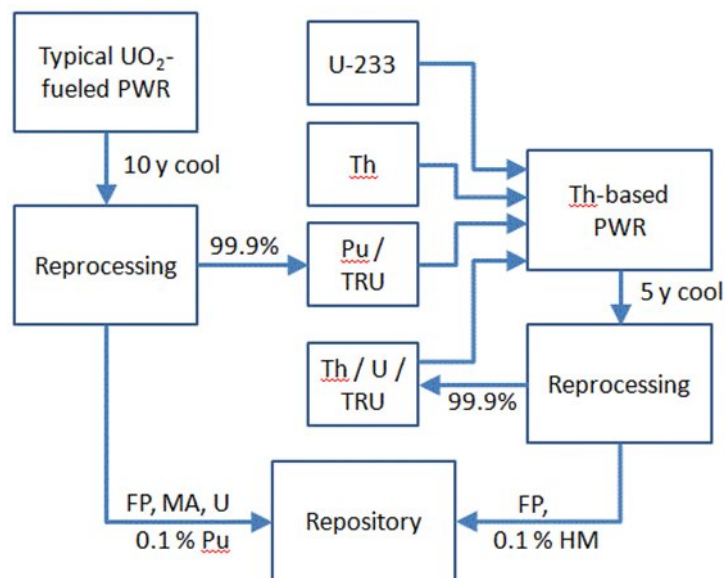

Figure 1. Recycling strategy

## RESULTS

### Homogeneous Th-TRU assembly design

The homogeneous Th-TRU assembly design has Th-TRU fuel in all 264 fuel pin locations. This design offers the simplest configuration and can achieve the highest TRU transmutation rate in a single recycle per batch of transmuting assemblies in a reload. Transmutation performance of homogeneous Th-based and homogeneous U-based assembly designs are compared in Table I. Note that results are given for both Pu and TRU feeds.

Table I shows an initial content of Pu in Th-MOX fuel of 514 kg/GWt-yr per batch, or ~10% of the HM content, vs. 372 kg/GWt-yr per batch in U-MOX, or < 7% of the HM inventory. For its initial load, a Th-MOX assembly would require the amount of Pu contained in ~7 UOX PWR UNF assemblies. The larger initial Pu content is required to offset the larger absorption crosssection of Th-232 vs. U-238. As a result, the spectrum in Th-MOX fuel will be harder than in U-MOX, thereby further reducing the neutron absorber worth, an effect that could impact reactivity control and shutdown margin and that deserves further studies.

In terms of transmutation, the Th-based assembly burns more Pu or TRUs than the corresponding U-based designs. This is predominantly due to the absence in Th-based fuel of the pathway for Pu-239 generation provided by U-238. After batch discharge and a 5-year cooling period, Th-MOX and Th-TRU assemblies transmuted 49% and 39% respectively of the initial TRU loading, compared with 23% and 21% for U-MOX and U-TRU assemblies, respectively. Hence, percent-wise, the TRU burning in Th-based fuels is almost twice as efficient as in U-based fuels. On a per-energy basis, Th-based fuels require a larger initial TRU loading, especially for the Th-Pu case, and burn between 2-3 times more TRU than the U-based counterpart. However, the relative amounts burned for a core depends on how many assemblies of either U-MOX or Th-MOX can be supported as the viability of 100% MOX cores, especially for the current plants, is questionable. From this respect, a larger fraction of U-MOX assemblies than Th-MOX assemblies could be supported due to the harder spectrum of the latter.

Table I. TRU transmutation for homogeneous U-based vs. Th-based fuel designs

(kg/GWt-yr per batch)	U-MOX			U-TRU			Th-MOX			Th-TRU		
	BOC	Delta	Delta %	BOC	Delta	Delta %	BOC	Delta	Delta %	BOC	Delta	Delta %
Thorium	0.0	0.0		0.0	0.0		5279.6	-161.2	-3%	5014.0	-155.4	-3%
Uranium	5423.3	-222.6	-4%	5100.1	-207.0	-4%	0.0	102.9		0.0	106.0	
<sup>233</sup> U	0.0	0.0		0.0	0.0		0.0	90.9		0.0	93.5	
<sup>235</sup> U	37.9	-22.5	-59%	35.7	-16.8	-47%	0.0	1.7		0.0	1.6	
Neptunium	0.0	5.6		0.0	5.7		0.0	0.1		41.7	-21.5	-52%
Plutonium	371.5	-119.2	-32%	690.8	-196.0	-28%	513.8	-284.3	-55%	735.1	-327.8	-45%
<sup>239</sup> Pu	200.4	-110.3	-55%	372.5	-175.7	-47%	277.2	-237.0	-85%	418.1	-303.4	-73%
Americium	4.0	21.0	523%	7.5	36.2	479%	5.6	24.9	447%	8.5	35.1	414%
Curium	0.0	6.5		0.0	7.7		0.0	7.3		0.0	8.3	
TRU	375.5	-86.1	-23%	698.4	-146.4	-21%	519.4	-252.0	-49%	785.2	-306.0	-39%

\*Note: Delta value represents the difference between BOC and EOC+Cooling mass flows in one recycle.

### Multi-recycling homogeneous Th-TRU design

Multi-recycling was performed assuming full recovery and recycle of actinides during reprocessing, disposition of the fission products, and using external TRU and Th feeds to provide the required fissile and fertile materials to preserve the cycle length. In such a multi-recycling scenario with homogeneous assembly design (i.e. Th-TRU-U pins of same composition throughout the assembly, where U is the in-bred U from Th), an increasingly larger TRU inventory at the beginning of each batch irradiation is observed. This increase is the result of the degradation of the fissile quality of the recycled fuel which leads to increasingly larger amounts of TRU inventory to preserve the batch reactivity. The growing TRU inventory and increasing fraction of higher actinides lead to a number of issues, such as increasingly radioactive fuel to be handled and manufactured. In addition, the homogeneous Th-TRU design allows performing only a limited number of recycles since, after those, the void reactivity coefficient turns positive as a result of the progressively increasing proportion of isotopes with threshold fission.

Figure 2 contains a collection of charts that shows, for a representative batch (i.e. 64 fuel assemblies), the evolution of relevant parameters over the number of recycles simulated. Note that each recycle accounts for batch loading, 4.5 EFPY irradiation with batch discharge, 5-year cooling, reprocessing, actinide recovery and recycle into a new batch, together with the required fissile and fertile feed materials, according to the strategy described previously. The charts show the content of Np, Pu, Am, Cm and U in the recycled fuel at beginning and end of irradiation vs. cycle, together with the external feed (positive) and amount transmuted during irradiation (note that a positive amount indicates that the nuclide is burned, while a negative indicates that the nuclide is built up during irradiation). It can be observed that while Np and Pu show a net burning as a result of irradiation, Am is built up during the first recycles and then burned. These isotopes (Np, Pu and Am) are also added as an external feed to compensate for the reactivity loss during irradiation. Notably, the feed supplied decreases with the number of cycles, but for Np and Pu so does the amount burned. In particular, the amount of Pu burned is always below the one fed, so that the overall amount of Pu in the fuel keeps increasing

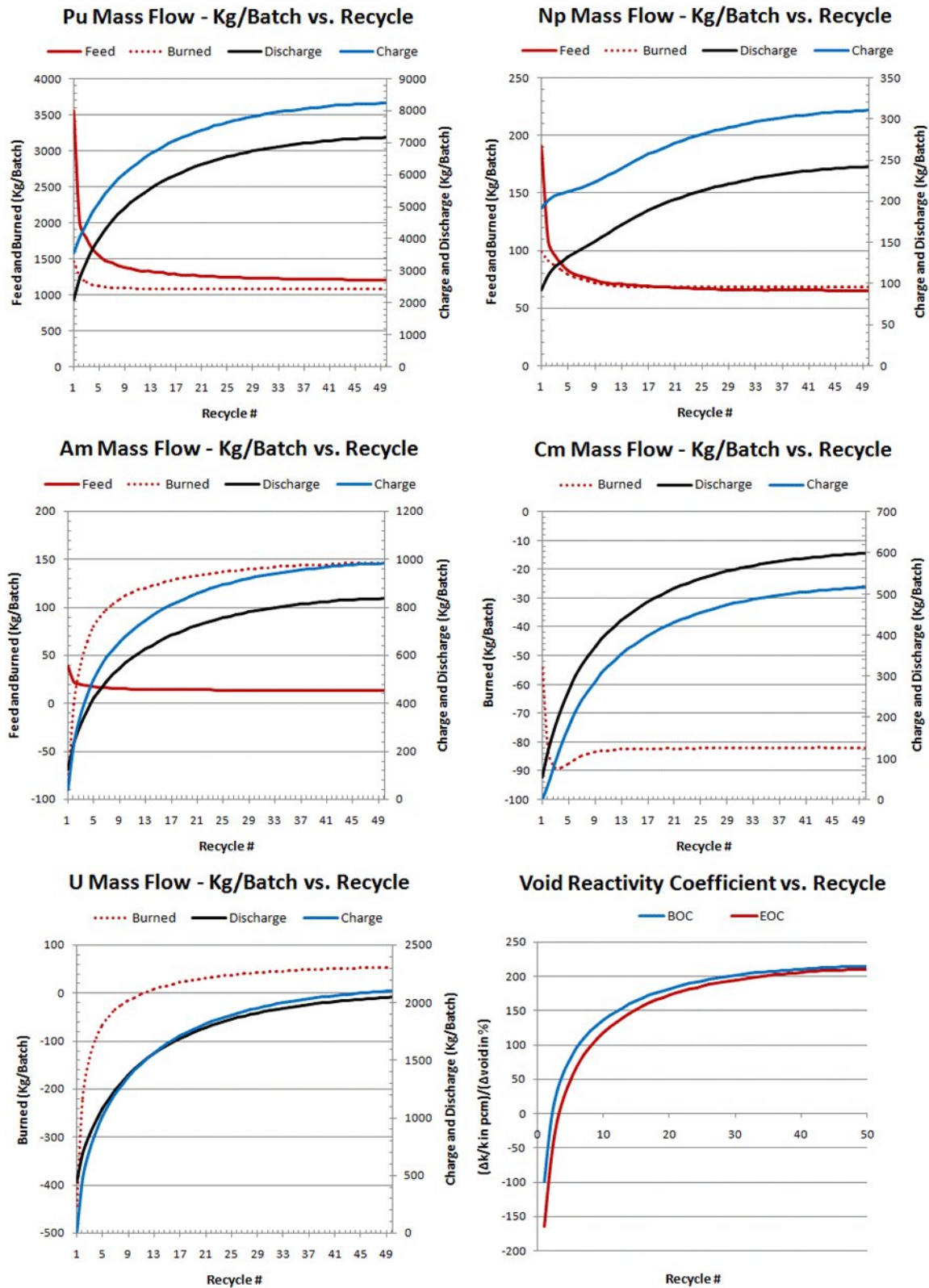

Figure 2. Multi-recycling charts for homogeneous Th-TRU assembly design  
 (Note that 1 recycle = 4.5 EFPY with 5-year cooling period)

throughout the simulation. The amount of Np also keeps increasing due to the increasing contribution of the in-bred component from the recycled U (from neutron capture in U-237 and beta decay to Np-237). The amount of Am burned exceeds that fed after the initial cycles, but the overall amount of Am at charge shows still an increasing trend as a result of increasingly larger amounts of Am-241 produced from the decay of Pu-241 during the 5-year cooling. Cm is not present in the external feed supply but quickly builds up due to the overall net generation during irradiation. After an initial transition, the amount of in-bred Cm during irradiation reaches a constant value, only partially counter-balanced by the Cm-242 and Cm-244 decay during the 5-year cooling. The amount of Cf, not shown, will also build up following the increasing Cm content.

The overall result of these trends is a rapid increase during the first few recycles of the amount of TRU in the recycled fuel, which quickly leads to a positive void reactivity coefficient in the fourth recycle, which is evident in the bottom-right chart that shows the void reactivity coefficient at the beginning (BOC) and end (EOC) of each cycle. Another major concern is that the fuel will become increasingly radioactive and difficult to handle and manufacture, with increasing rate of neutron emission (from Cm and then Cf) and hard gammas from U-232 and Th-228 decay's daughters. The in-bred U content in the recycled fuel is shown in the bottom-left chart. U is first bred during irradiation, at a decreasing rate with increasing recycles, and eventually burned. The U-232 and Th-228 amount increases following the increase in the U. The U-232 quickly reaches a peak of ~ 5,000 ppm of U and stabilizes at ~3,000 ppm of U. Hence the void reactivity coefficient is expected to limit the number of recycles that can be performed with the homogeneous assembly design, with additional challenges from the increasingly radioactive recycled fuel.

### **Multi-recycling heterogeneous Th-U design (modified CORAIL, nitride)**

Multi-recycling heterogeneous assembly designs with Th-based fuel for PWRs have been already studied in the past [4-5]. The assembly design developed by Sorensen and Lee [4] was based on a modified version of the CORAIL assembly [6]. In their multi-recycling approach, only Pu was recycled and the rest of HMs and FPs were sent to the repository. The external feeds used were U-233 and Pu waste discharged from PWRs and cooled for 10 years. The design demonstrated TRU burning and satisfied safety limits but required a feed of external fissile materials (U-233 in addition to Pu). The studies developed here aimed instead at having a fully closed thermal cycle, recycling all the TRUs (and not only Pu), while avoiding a U-233 external feed from recycled fuel.

With these objectives in mind, assembly designs were developed using thorium nitride instead of thorium oxide, to take advantage of the higher heavy metal density,  $11.2 \text{ g/cm}^3$  for ThN [9] vs.  $8.8 \text{ g/cm}^3$  for ThO<sub>2</sub> [10], and remarkable thermal properties, i.e. 4-20 times larger thermal conductivity over the 100-1200°C temperature range [9-10]. The higher density of the nitride promotes a better internal breeding. For the same fuel pin outer diameter (OD) and linear power, the larger thermal conductivity results in lower fuel temperatures and thus increased thermal margin. Alternatively, as proposed in this study, the enhanced thermal margin allowed by nitride can be reduced to still acceptable values by increasing the fuel pin OD, as to further enhance the U breeding from Th. It should be noted that natural N has been assumed for this study, which leads to relatively large parasitic absorptions from (n,p) reactions with N-14, thereby decreasing neutron economy and generating radioactive C-14, which is a health hazard. Future studies will include the analysis with N-15 enriched N.

The quarter assembly layout for the base nitride fuel assembly design is shown in Figure 3. The blue pins indicate (Th,Pu/TRU)N pins while the yellow ones indicate (Th,U-233)N pins. Note that no burnable absorbers have been used for this preliminary round of calculations in the nitride fuel assembly. The potential use of a resonant absorber, such as  $\text{Er}_2\text{O}_3$  or  $\text{Gd}_2\text{O}_3$ , may further contribute to improve the void reactivity coefficient and reduce the power peaks, at the cost of a residual reactivity penalty.

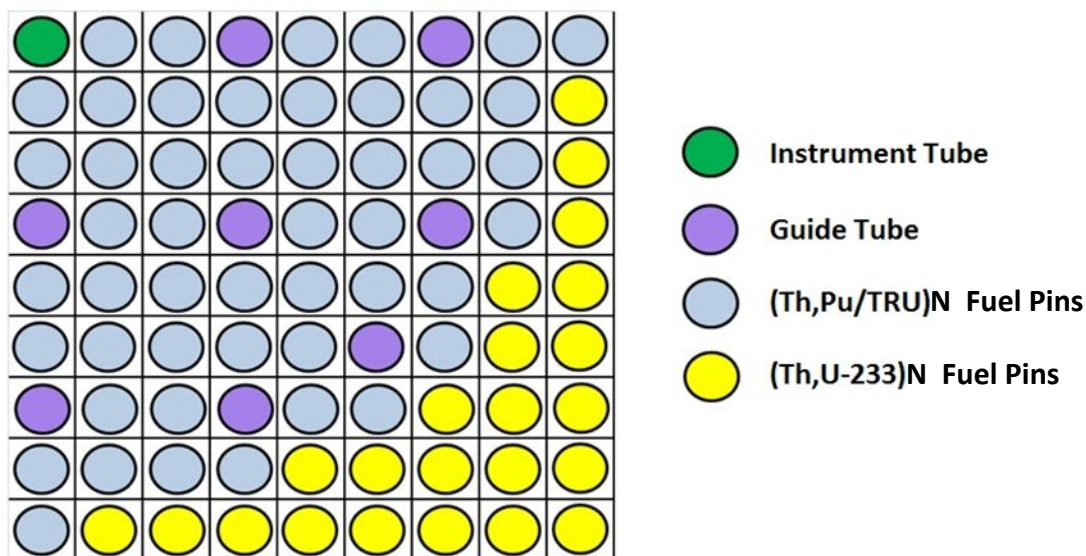

Figure 3. CORAIL quarter assembly layouts modified for thorium nitride fuel

For the multi-recycling analysis, four nitride fuel assembly designs were evaluated, differing for the type of fissile feed (Pu or TRU) and the fuel pin size (“standard” = 0.82 cm diameter pellets; “large” = 1.10 cm diameter pellets<sup>1</sup>). In each design, all the fuel pins have the same size. The four cases are as follows:

- Case 1. Pu feed; standard fuel pin OD
- Case 2. Pu feed; large fuel pin OD
- Case 3. TRU feed; standard fuel pin OD
- Case 4. TRU feed; large fuel pin OD

For all cases, each discharge batch is cooled for 5 years before the fuel is reprocessed and all HM recycled into a new batch for the following cycle, together with the required top-up fissile and fertile materials from the Pu or TRU feed. Only the FPs are separated and sent to the repository.

Figure 4 and Figure 5 depict the performance of cases 1 and 2, i.e. Pu feed with standard and larger fuel pin OD respectively. Note that the batch average values are given, so the isotopics from all pins of the average assembly, Th-Pu and Th-U, are added up and multiplied for all the assemblies in a batch (e.g. 64 in our case).

<sup>1</sup> The choice of 1.10 cm diameter pellets for the “large” pin cases was based on a previous study on multi-recycling Th-U233 in a Seed Blanket Unit design [7]. The 1.10 cm pellets case is an upper bound for the 17x17 lattice with 1.26 cm fuel rod pitch and has been chosen here only to illustrate potential neutronic advantages of a reduction in the moderator to coolant ratio.

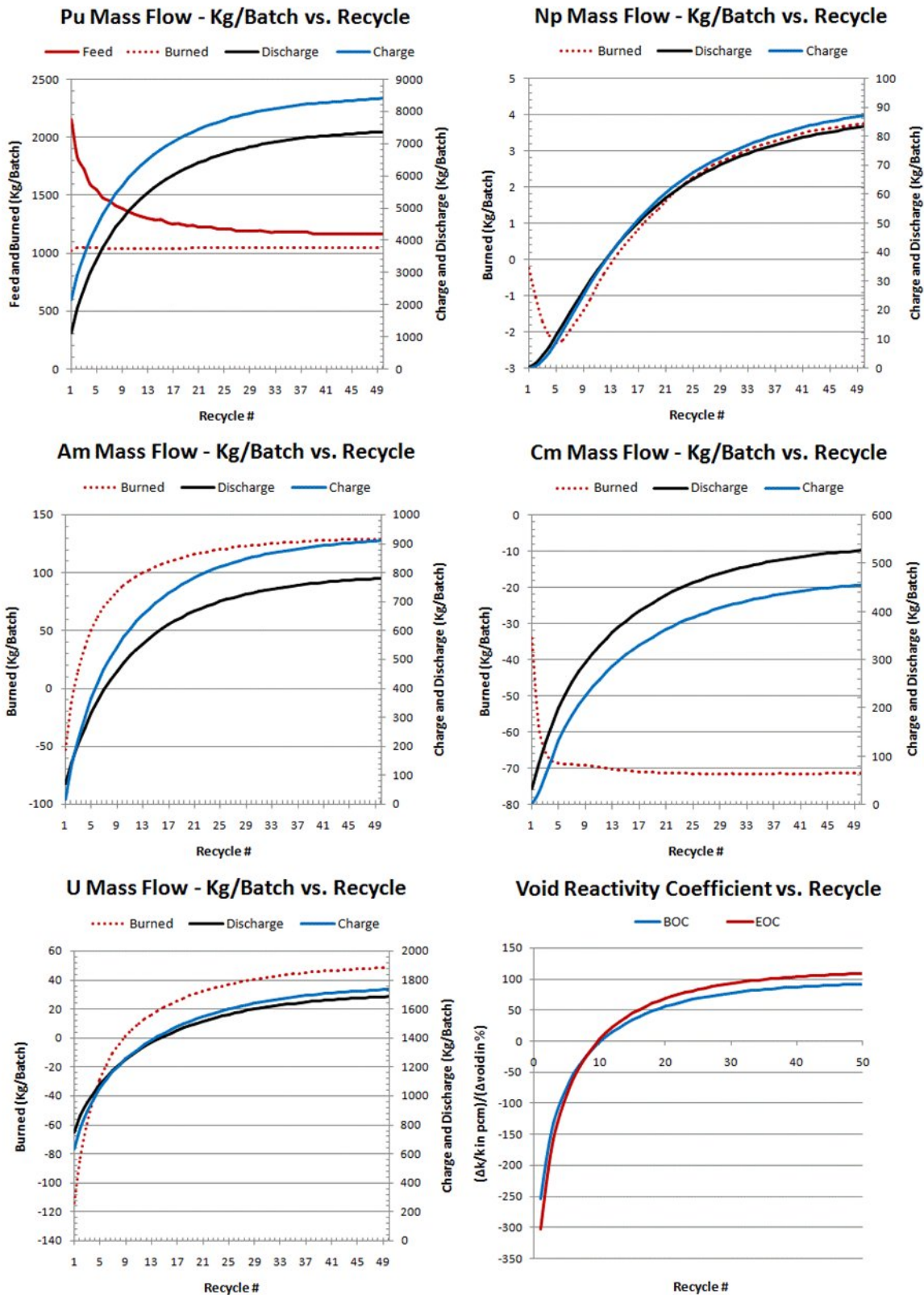

Figure 4. Multi-recycling performance of nitride fuel Case 1 (Pu feed, standard pin size)



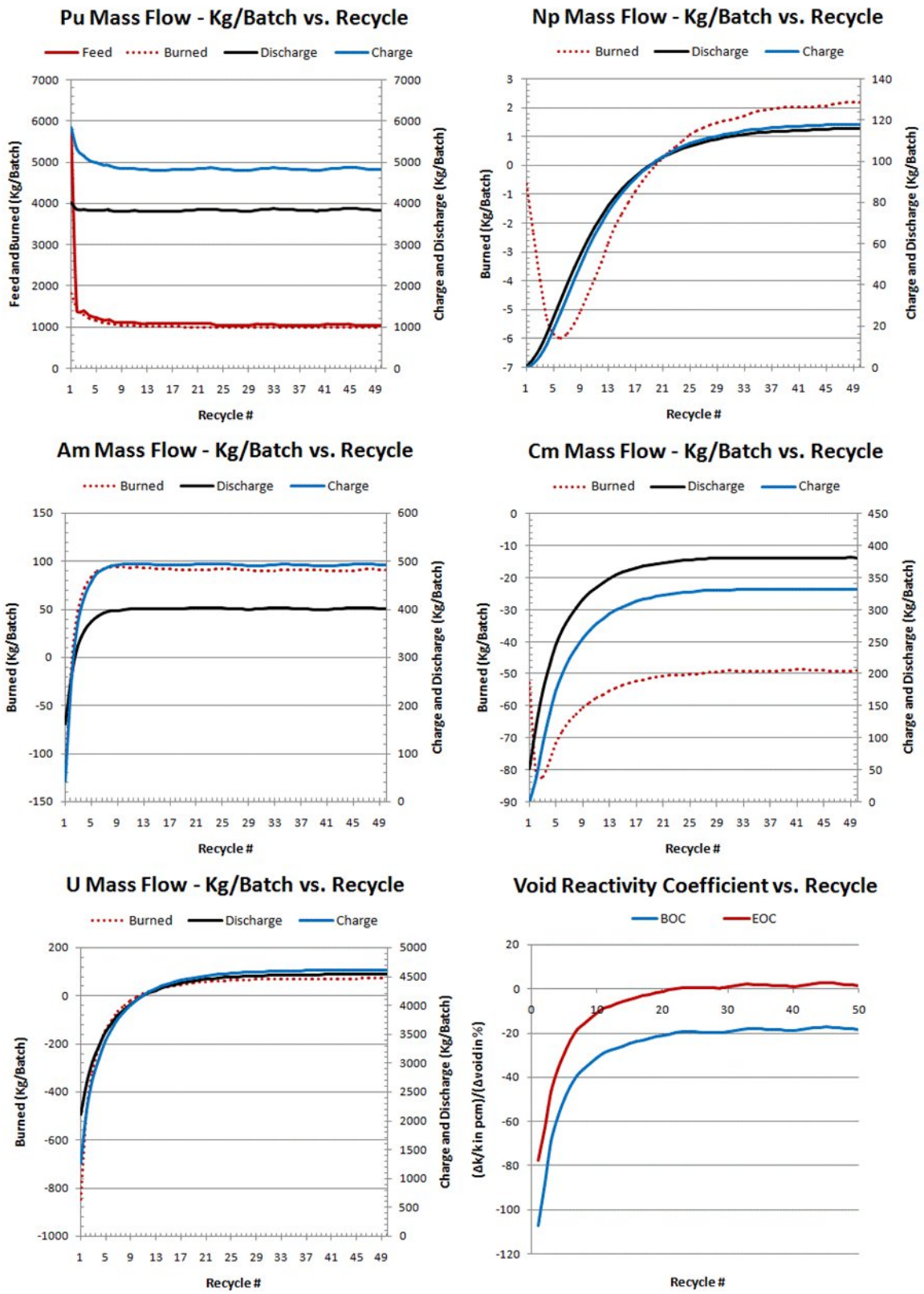

Figure 5. Multi-recycling performance of nitride fuel Case 2 (Pu feed, large pin size)

The amount of in-bred U is more than doubled in the larger vs. the standard fuel design (bottom-left chart). The larger internal breeding offsets the increase in the fissile required from the external Pu supply. In this way the amount of Pu and other TRUs quickly reaches a steady level, resulting in an increased number of recycles that can be sustained before the void reactivity coefficient turns positive. In the case of the larger pin OD assembly in Figure 5, the void reactivity coefficient just barely turns positive at recycle #22. This is likely not to be an issue, as it can be resolved by design improvement and/or by performing more accurate (3D) calculations crediting the increased leakages in the presence of voiding and their beneficial effect on the void coefficient.

Table II summarizes the comparison between cases 1 and 2 at equilibrium. Notice that there is much more thorium and U-233 in the larger pin OD assembly and a slightly better TRU transmutation. In both cases, we achieve a net TRU transmutation by closing the cycle only needing a steady state of UNF from PWR to feed Pu. This is made possible by maintaining the U-233 inventory through the cycles with virtually no delta change between BOC and EOC+cooling as evident in Table II. Hence there is enough U-233 at the batch reprocessing to reconstitute the Th-U pins, maintaining the same number and approximate same reactivity through the recycles for both fuel dimensions.

Table II. Comparison of nitride fuel cases 1 and 2

(kg/GWt-yr per batch)	NITRIDE, PU FEED, STANDARD OD			NITRIDE, PU FEED, LARGER OD		
	BOC	Delta	Delta %	BOC	Delta	Delta %
Thorium	5020.9	-124.7	-2%	11411.7	-446.3	-4%
Uranium	374	0.4	0%	994	0.0	0%
<sup>233</sup> U	144	-0.1	0%	585	-0.1	0%
<sup>235</sup> U	38	0.0	0%	92	0.0	0%
Neptunium	18.8	0.1	0%	25.4	0.0	0%
Plutonium	1814.5	-248.2	-14%	1038.0	-226.2	-22%
<sup>239</sup> Pu	411.9	-141.1	-34%	271.8	-126.9	-47%
Americium	196.1	1.0	1%	106.0	-0.3	0%
Curium	98	0.2	0%	72	0.0	0%
TRU	2127.6	-246.8	-12%	1241.0	-226.4	-18%

\*Note: Delta value represents the mass difference between BOC in recycle 1 and EOC+Cooling in recycle 50.

Figure 6 and Figure 7 depict the performance of cases 3 and 4, i.e. TRU feed with standard and larger pin OD respectively. The trends observed are similar to those of their counterpart with Pu feed, case 1 (Figure 4) and case 2 (Figure 5) respectively for the standard and larger OD. The differences are determined by the lower fissile quality of the TRU feed compared to the Pu feed, which leads to an increase in TRU feed and TRU content for cases 3 (Figure 6) and 4 (Figure 7). Following the increase in the TRU content, the number of recycles that can be performed without incurring a positive void reactivity coefficient is reduced.

Table III summarizes the comparison between cases 3 and 4 at equilibrium. Again, we see the same trend as in case 1 and case 2 in Table II previously where there is much more thorium and U-233 in the larger pin OD assembly and a slightly better TRU transmutation. Although we again achieve a net TRU transmutation by closing the cycle, there is still the issue of burning the cumulated core inventory at equilibrium, which can only be done by further increasing the U breeding in the core or moving the TRU to a fast reactor.

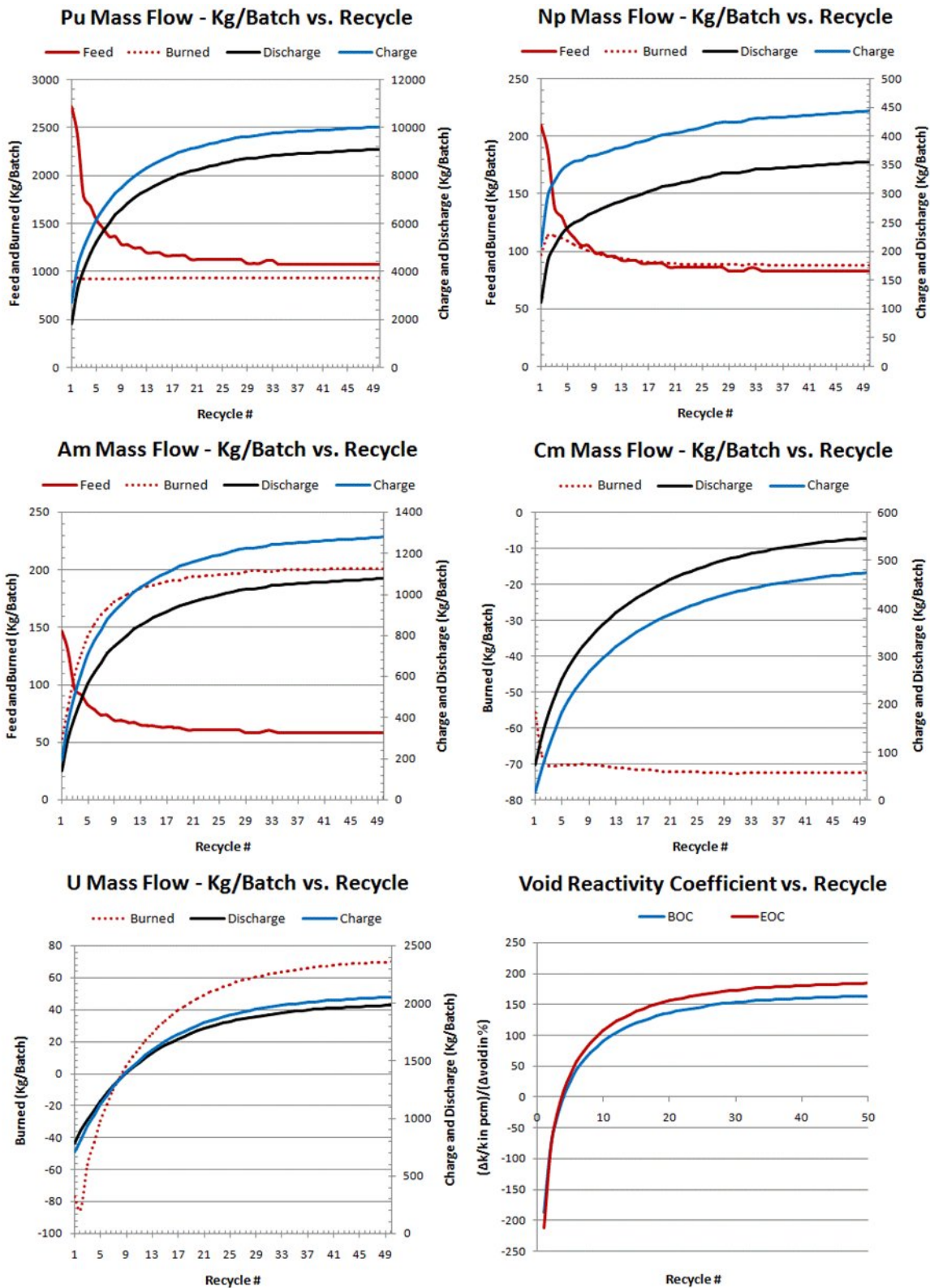

Figure 6. Multi-recycling performance of nitride fuel Case 3 (TRU feed, standard pin size)

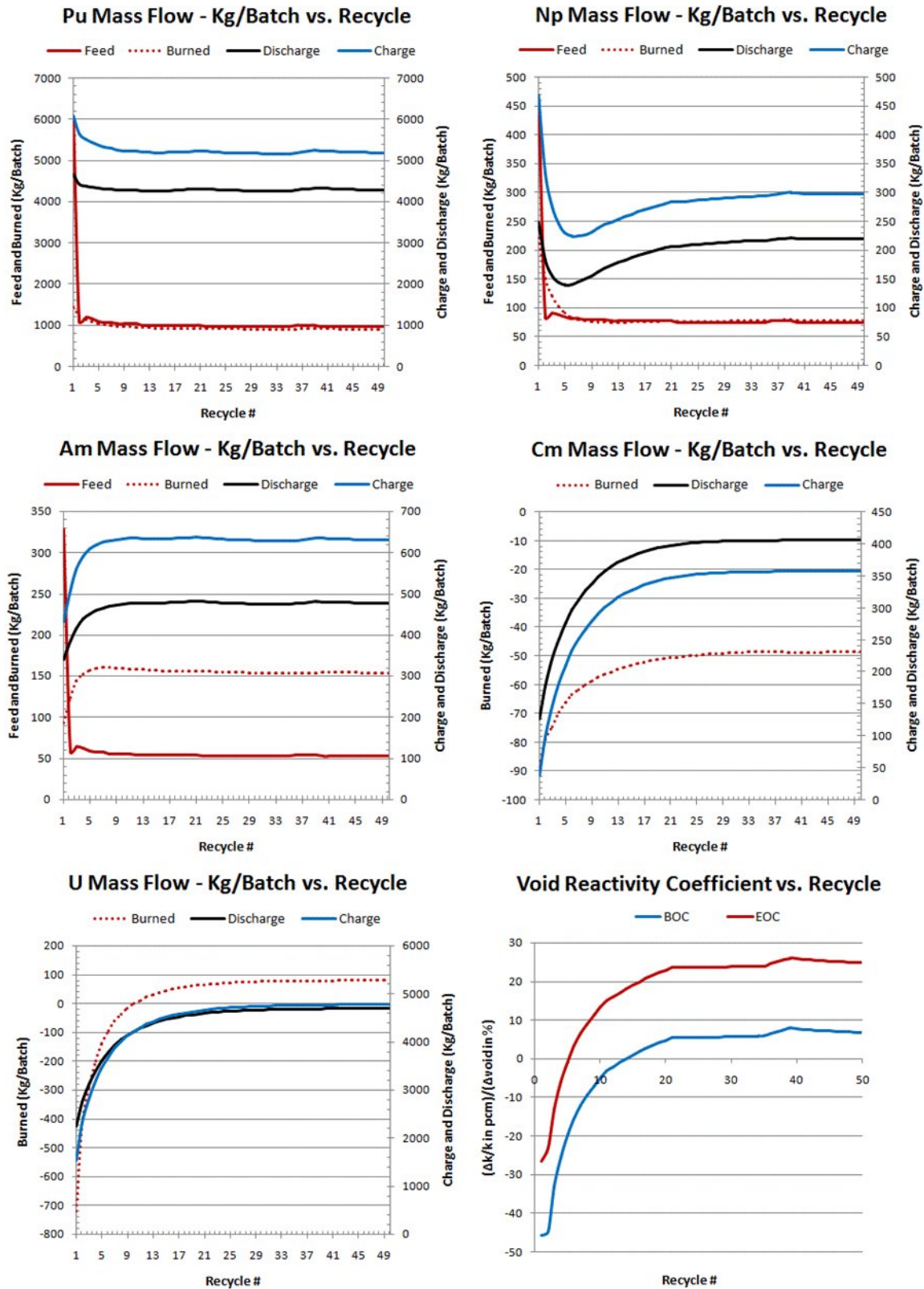

Figure 7. Multi-recycling performance of nitride fuel Case 4 (TRU feed, large pin size)

Table III. Comparison of nitride fuel cases 3 and 4

(kg/GWt-yr per batch)	NITRIDE, TRU FEED, STANDARD OD			NITRIDE, TRU FEED, LARGER OD		
	BOC	Delta	Delta %	BOC	Delta	Delta %
Thorium	4457.7	-111.6	-3%	11218.0	-432.0	-4%
Uranium	442	0.4	0%	1029	0.1	0%
<sup>233</sup> U	143	-0.1	0%	590	0.0	0%
<sup>235</sup> U	57	0.0	0%	97	0.0	0%
Neptunium	95.5	-17.7	-19%	63.9	-16.1	-25%
Plutonium	2161.1	-229.1	-11%	1117.3	-210.2	-19%
<sup>239</sup> Pu	491.4	-130.3	-27%	286.9	-118.2	-41%
Americium	275.5	-13.3	-5%	135.8	-13.4	-10%
Curium	102	-1.2	-1%	77	-1.3	-2%
TRU	2634.4	-261.4	-10%	1394.0	-241.1	-17%

\*Note: Delta value represents the mass difference between BOC in recycle 1 and EOC+Cooling in recycle 50.

## CONCLUSIONS

Various assembly designs have been proposed to assess the TRU burning potential of Th-based fuel in PWRs. In addition to typical homogeneous loading patterns, heterogeneous configurations exploiting the breeding potential of thorium to enable multiple cycles of TRU irradiation and burning have been devised.

The homogeneous assembly design, with all pins featuring TRU in Th, has the benefit of a simple loading pattern and the highest rate of TRU transmutation, but it can be used only for a few cycles due to the rapid rise in the TRU content of the recycled fuel, which challenges reactivity control, safety coefficients and fuel handling. Due to its simple loading pattern, such assembly design can be used as the first step of Th implementation, achieving up to 3 times larger TRU transmutation rate than conventional U-MOX, assuming same fraction of MOX assemblies in the core.

As the next step in thorium implementation, heterogeneous assemblies featuring a mixed array of Th-U and Th-U-TRU pins, where the U is in-bred from Th, have been proposed. These designs have the potential to enable burning an external supply of TRU through multiple cycles of irradiation, recovery (via reprocessing) and recycling of the residual actinides at the end of each irradiation cycle. This is achieved thanks to a larger breeding of U from Th in the heterogeneous assemblies, which reduces the TRU supply and thus mitigates the increase in the TRU core inventory for the multi-recycled fuel. While on an individual cycle basis the amount of TRU burned in the heterogeneous assembly is reduced with respect to the homogeneous design, TRU burning rates higher than single-pass U-MOX fuel can still be achieved, with the additional benefits of a multi-cycle transmutation campaign recycling all TRU isotopes. Nitride fuel, due its higher density and U breeding potential, together with its better thermal properties, ideally suits the objectives and constraints of the heterogeneous assemblies. However, significant technological advancements must be made before nitride fuels can be employed in an LWR: its water resistance needs to be improved and a viable technology to enrich N in N-15 must be devised. Moreover, for the nitride heterogeneous configurations examined in this study, the enhancement in TRU burning performance is achieved not only by replacing oxide with nitride fuel, but also by increasing the fuel rod size. This latter modification, allowed by the high thermal conductivity of nitride fuel, leads however to a very tight lattice,

which may challenge reactor coolant pumps and assembly hold-down mechanisms, the former through an increase in core pressure drop and the latter through an increase in assembly lift-off forces. To alleviate these issues, while still achieving the large fuel-to-moderator ratios resulting from using tight lattices, wire wraps could be used in place of grid spacers. For tight lattices, typical grid spacers are hard to manufacture and their replacement with wire wraps is known to allow for a pressure drop reduction by at least 2 times [11].

The studies, while certainly very preliminary, provide a starting point to devise an optimum strategy for TRU transmutation in Th-based PWR fuel. The viability of the scheme proposed depends on the timely phasing in of the associated technologies, with proper lead time and to solve the many challenges. These challenges are certainly substantial, and make the current once-through U-based scheme pursued in the US by far a more practical (and cheaper) option. However, when compared to other transmutation schemes, the proposed one has arguably similar challenges and unknowns with potentially bigger rewards.

## REFERENCES

- [1] M. Carelli, F. Franceschini, E. Lahoda, B. Petrovic, "A novel fuel/reactor cycle to implement the 300 years nuclear waste policy approach," Waste Management Conference (2012).
- [2] F. Franceschini, A. Sartori, M. Wenner, P. Ferroni, M. Ricotti, "Transuranic waste burning potential of thorium fuel in a fast reactor," Waste Management Conference (2012).
- [3] M.J. Driscoll, T.J. Downar, E.E. Pilat, "The Linear Reactivity Model for Nuclear Fuel Management", ISBN 0-89448-035-9 American Nuclear Society (1990).
- [4] R. Sorensen, J. Davis, J. Lee, "Thorium-based Fuels for Enhancing Plutonium Transmutation in Light Water Reactors", *Trans. Am. Nucl. Soc.*, **94**, 87 (2006).
- [5] J. Davis, R. Sorensen, J. Lee, R. Fleming, "Transmutation Characteristics of Thorium-based Fuel in a Multiple-Tier Fuel Cycle", *Trans. Am. Nucl. Soc.*, **92**, 651 (2005).
- [6] G. Youinou, et al, "Heterogeneous Assembly for Plutonium Multi-recycling in PWRs: The CORAIL Concept", GLOBAL 2001, Paris, France.
- [7] D. Yun, T.K. Kim, T.A. Taiwo, "Th/U-233 Multi-recycle in PWRs," ANL-FCRD-309, August 11, 2010.
- [8] M. Edenius et al., CASMO-4: A Fuel Assembly Burnup Program, User's Manual, STUDEVIK/SOA-95/1.
- [9] Thorium ceramics data manual, Volume 2: Nitrides. Oak Ridge National Laboratory, ORNL-4503, 1973.
- [10] Properties of Thorium, its alloys, and its compounds. Oak Ridge National Laboratory, ORNL-TM-1144, 1965.
- [11] Figure 9.30 in: N.E. Todreas, M. Kazimi, Nuclear Systems, Volume 1 – Thermal Hydraulic Fundamentals. Second Edition. CRC Press, Taylor & Francis Group, 2011.