

## **Remote System for Characterizing, Monitoring and Inspecting the Inside of Contaminated Nuclear Stacks - 11567**

Mario Vargas (DOE Fellow)\*, William Mendez (DOE Fellow)\*, Dr. Leonel Lagos\*,  
Randall Lind\*\*, Peter Lloyd\*\*, John Rowe\*\*, Mark W. Noakes\*\* and François Pin

\*Florida International University, Applied Research Center, Miami, Florida 33016

\*\*Oak Ridge National Laboratory, Oak Ridge, Tennessee 37831

### **ABSTRACT**

The Stack Characterization System (SCS) is a collaborative project with the Robotics and Energetic Systems Group (RESG) at Oak Ridge National Laboratory (ORNL) and the Applied Research Center (ARC) at Florida International University (FIU). The SCS is a robotic system that will be deployed into off-gas stacks located around the central campus at ORNL. The system will consist of surveying equipment capable of taking surface contamination samples, radiation readings, core samples and transmit live video to its operators. Trade studies were conducted on varying concrete materials to determine the best way of retrieving loose contamination from the surface. The studies were performed at the ARC facility by FIU students, where traditional cloth wipes were compared to adhesive material. The adhesive material was tested on the RESG's smear sampler to record how much loose surface material could be retrieved. The FIU students completed a summer internship during which conceptual designs were created for a deployable radiation detector and core drill capable of retrieving multiple core samples.

### **INTRODUCTION**

The objective of the project is to provide an approach to characterize contaminated off-gas stacks; some of which can be highly contaminated and/or possibly structurally deteriorated. The SCS removes workers from potential harm and reduces the probability of spreading contaminants to the areas nearby. The Central Campus Closure Project at ORNL focuses on demolishing a large number of facilities, which also includes the off-gas stacks. The stacks located on the ORNL central campus have inside wall diameters that range from 1.8 to 6.7 meters (6 to 22 ft) with heights ranging from 53 to 76 m (175 to 250 ft). Some of the stacks are made of steel reinforced concrete and brick liners while others are made of unreinforced radial brick masonry with varying brick sizes and an acid-proof lining. The stacks are located in a densely populated area of ORNL, next to currently active operating facilities. Before removing the stacks, waste segregation requirements dictate that the stack must be characterized. However, it is hazardous to place humans in close proximity to or inside stacks with unknown structural integrity. In addition, full personal protective equipment restricts the available operation time as well as limits the human range of motion and dexterity, impacting the quality and efficiency of task completion. Typical alternatives are to sample just around the top of the stack and at access points near the bottom of the stack. Characterization coverage is limited to available areas and not necessarily the areas most likely to be contaminated. A remote characterization system that characterizes the quantitative and qualitative level of contamination inside of off-gas stacks prior to demolition would address these concerns.

## REQUIREMENTS

Before design work began meetings were held with health physics, (HP), structural engineering and waste management staff at ORNL to establish lists of requirements that the SCS needs to meet. The health physics staff focuses on worker safety and site contamination issues, the structural engineering staff is concerned with structural and mechanical integrity of the stack and how that may impact characterization and demolition operations. Waste management is concerned with data collection for waste disposal requirements. A campaign will involve the descent of the system into the stack while it collects video and records the position and orientation of the surveying instruments so that the samples taken can be identified with a specific location in the stack. Live video of the campaign will be taken from within the stack with real time feed from cameras that will be mounted at different locations on the SCS. The real time camera feeds will allow the operators to see as they maneuver the SCS in and out of the stack and as they take the samples needed for the campaign. Any video taken can be used for future reference. Direct radiation measurements can include alpha/beta/gamma surveying and can be surveyed at pre-determined intervals in the stack or can be selected from evaluating the live video data. Smear sampling will be done with the aid of the video feeds as well as being taken at pre-determined intervals throughout the stack. The samples taken will be packaged, stored and cataloged according to their respective locations within the stack. The radiation detectors will be implemented for radiological survey data that will be available to the operator to identify possible hot spot regions or regions that require further examination. From estimates gathered by the ORNL HP staff a single stack survey could take up to two weeks to complete. The intent of the SCS is to complete the survey more quickly and without any risk of personnel exposure to the potentially hazardous environment. The three areas of concern (HP, Structural, Waste Acceptance) may require separate sampling runs. Alternately, it may be possible to complete the structural and radiological surveys simultaneously. Waste disposition needs a preliminary evaluation of the radiological data to determine whether or not coring of the stack walls must be done, how many samples will be required, and where those samples should be taken.

Staff from the three areas of concern have different requirements for the SCS:

### *HP Data*

- Live and recorded video to identify areas of interest inside the stack.
- Beta/gamma and alpha surveys to detect radiation levels (live for immediate decision making and recorded for post analysis).
- Smear samples to determine the presence of loose contamination.

### *Structural Engineering*

- Live and recorded video to identify areas of interest inside the stack and for structural inspection (cracks, etc.). Video must be continuous and cover the entire internal surface of the stack.

### *Waste Acceptance Criteria*

- Live and recorded video to identify areas of interest inside the stack.
- Core samples to determine detailed makeup for waste disposal in structural materials, including concrete and brick. Core samples are not automatically required; determination of need is based on radiological survey results.

The SCS needs to be able to accommodate deployment into stacks of various heights with inside diameters of less than 1.8 to 3.4 meters (6 ft to 11.25 ft) at the top and 2.1 to 6.7 meters (7 ft to 22 ft) at the bottom. It must also be possible to extract the SCS from the stack under all circumstances in the event of partial or complete failure of the system without damaging the stack. The SCS is not required to accommodate any reinforcing cross braces that may obstruct the inside of the stack. The SCS needs to record the sampling positions within the stack to within  $\pm 15.24$  cm ( $\pm 6$  inches) vertically and circumferentially along the inside surface of the stack. It needs to provide for incremental movement and sampling of hot spot samples. It does not need to provide continuous surface scanning from any of the sensors although continuous video operation will be provided. It needs to operate on available ORNL plant power with no major modifications required. A local operator station will provide real-time remote control of the SCS for the duration of the survey. The operator station will provide remote viewing to the operator, the ability to control all functions of the SCS, and the ability to communicate with the site operations and contractors to coordinate SCS stack insertion, location in the stack, and the survey process. The operator station shall provide a means of recording the sampling process or sensor data (e.g., real-time beta/gamma) or cataloging samples that need post-processing to positions and video in the stack. All the data taken must be correlated to position and location in the stack by the survey process. The operator station will accommodate local remote viewing and communication with a team of health physicists, structural engineers, and waste management staff in order to guide the survey if unknown conditions or unexpected areas of interest are encountered during the process. Because there are multiple stacks that need characterization, the SCS needs to be reusable. It is not intended to be used once and then disposed of. In the event that the SCS does find moderate contamination levels within the stacks, it needs to be able to be decontaminated. The SCS does not need to provide its own decontamination system because decontamination would be an operations function.

## **DESIGN**

The design of the SCS consists of the following subsystems: (1) the SCS stabilization and sensor deployment structure (the main SCS system), (2) the radiation detector deployment system, (3) the smear sampler, and (4) the core drill system. The SCS containment system will be designed and implemented in simplified form as part of cold testing. Stack top containment will begin with the minimum necessary to initiate cold testing and expand as testing is conducted. Deployment specific containment will be part of the follow up hot deployment. FIU is currently working on a scale model of the SCS containment system. The model will be scaled down to about 36.5 cm (1.2 ft) and will have a base with three adjustable legs that will sit on top of the stack. The plastic sheeting that will make up most of the containment system will be added to the top of the base and its final scaled diameter will be 20.32 cm (8 inches). Once the model is complete, it will be tested in a low air speed wind tunnel and the plastic sheeting will be lowered to mimic the SCS as it is lowered into the stack. The effects of the wind will be documented to ensure that the containment system will not be toppled from the top of the stack while the SCS is already lowered into the stack.

The overhead crane that is leased to deploy the SCS into the stack is also used to control the vertical motion of the SCS while it is lowered inside the stack. The main SCS system (Fig. 1) consists of a rotatable tripod stabilization mechanism mounted on top of a bipod sensor and

sampler deployment mechanism. The mechanism collapses to permit insertion into the stack. In operation, the upper tripod first extends so that its arms make contact and stabilize against the inner stack wall. Once the tripod has been stabilized, rotation will orient the bipod mechanism within the stack to the target area of interest. Once the bipod is positioned, it is extended until the outer surfaces of the bipod contact the stack. The outer surface of the bipod consist of two instrument bays: the first instrument bay contains a radiological detector and an automated multi-sample “smear” removable contamination sampler and the other bay contains a multi-sample core drill. Besides actuation, the main SCS contains camera systems with pan-tilt-zoom capability, lighting, controls and communications (hardwired on board the SCS and wireless to the overhead crane and base station), and battery power.

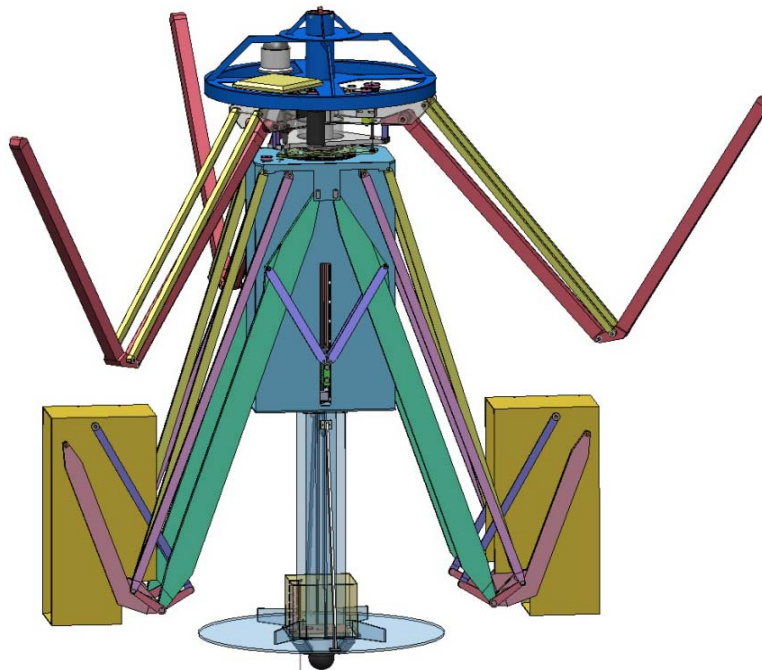

Fig. 1. SCS main structure.

## **RADIATION DETECTOR SYSTEM**

FIU performed work on the conceptual design for the radiation detector deployment mechanism. The radiation detector head must be deployed from the instrument bay to the stack wall at a distance of 6.35 mm (¼ inch) with a tolerance of  $\pm 3.17$  mm ( $\pm 1/8$  inch). However, it must be retracted and protected during movement of the SCS. The detector positioning assembly is shown in Fig. 2. A small linear actuator is used to move the detector in and out. A limit switch manages the standoff distance from the wall.

The Rad Sensor Bay deploys both of the radiation detectors. The dedicated Rad Sensor Bay PLC controls deployment of the radiation detectors to the stack wall after the SCS bipod has deployed. Limit switches act as feelers to control the detector standoff distance during measurement. The detector is powered during the entire stack entry. One of two detectors can be deployed: a RadEye SX head with a Ludlum 43-1-1 detector to discriminate alpha from

beta-gamma or a RadEye GX head with a Ludlum 44-88 detector for alpha-beta-gamma. Procurement of the detectors has been coordinated with ORNL Health Physics. Data is acquired through the Ethernet network using an USB to Ethernet converter tied to the detector head.

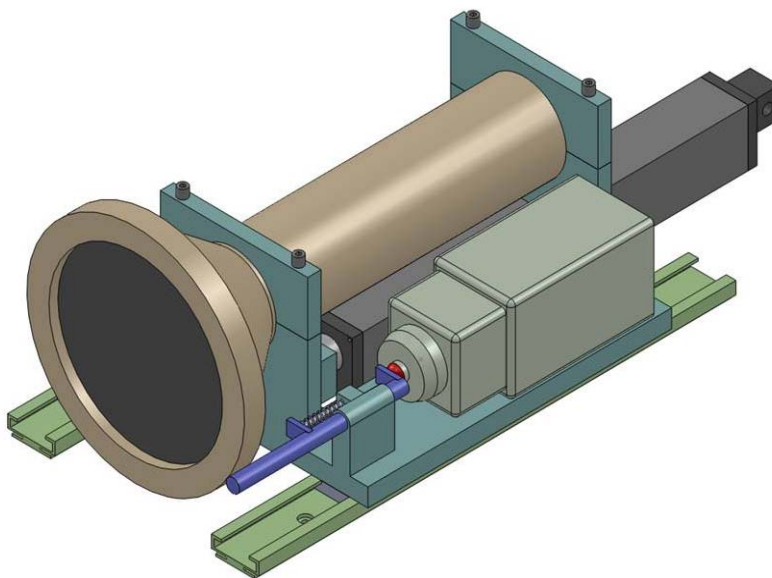

Fig. 2. Detector positioning system, assembly view.

## **SMEAR PAD SELECTION AND TRADE STUDIES**

In order to take loose contamination samples from within the stack, a “smear sampling” technique will be implemented. Traditional smear sampling uses a circular cloth swipe to take samples on a surface. Rather than using a cloth swipe that may tear and rip on concrete surfaces, double-sided adhesive foam tape will be used. FIU performed trade studies on the adhesive tape to evaluate its performance. The purpose of the study was to empirically evaluate the collecting capacity of contamination of two different wipes. The nature of the study was qualitative; the objective was to evaluate the amount of dust removed by two different types of wipe available on the market. Two main elements of the experiment were carefully prepared in order to simulate the environment of the inside of a nuclear stack: first, the surfaces, and second, the contaminant on the surface.

Three types of surfaces were created on concrete material: rough, semi-rough and smooth. The concrete surfaces were created by pouring the concrete into three 30.48 cm × 30.48 cm (1 ft × 1 ft) wooden grids. The grids were constructed using four 30.48 cm (1 ft) long slabs of wood held together with wood screws. The concrete was poured into the grid and on top of the Plexiglas, which made up the bottom cover of the grid. Three grids were used for the testing of the three different surfaces: smooth, rough and semi-rough. The concrete was poured into the three grids in the same way; the only difference being the surface finish. The smooth surface was created by the contact between the Plexiglas and the concrete. The rougher surfaces were hand shaped.

To simulate contaminants on the surface, solutions were prepared by mixing powder and ethanol. One mixture was created using 30 mL of ethanol and 400 mg of black fluorescent powder. These ingredients were mixed together in a 50 mL plastic vial. A second mixture using white powder was created using the same amounts of ethanol and powder. The powder was first poured into a plastic weighing dish. The weight of the plastic dish was subtracted from the overall combined weight of the dish and the powder to determine the weight of the powder. The powder was then poured into the 50 mL vial that already contained 30 mL of ethanol. The powder mixtures were sprayed evenly onto the surfaces with the use of a spray bottle. An overview of the experimental procedure is as follows:

1. Preparation of the surface (concrete, grid template).
2. Preparation of the mixture to simulate the contamination.
3. Application of the mixture on surface.
4. Wiping the surface.
5. Taking pictures of the surface after the wipe has been done.
6. Comparison between the two wipes.

Two different wipes were tested, one sticky and one non-sticky. The non-sticky wipes have a 25.4 mm (1 in) diameter and the sticky wipes are 50.8 mm × 50.8 mm (2 in × 2 in). Each one of the three surfaces was tested with both sets of wipes. Two of the surfaces, the smooth and the rough, had the white powder applied to it and the semi-rough surface had the fluorescent black powder applied to it.

The results from the experiment indicated that sticky wipes were able to collect more transferrable material than the regular wipes. As expected, there was not a pattern to the amount of mass collected for each experiment, this was due to the irregular distribution of the contamination on the surfaces as well as non-uniform wipe surfaces and porosity. Additional experiments were needed to reduce the analytical variability and provide more data for analysis. The next experiment used test samples of equal weight. This helped to reduce analytical errors and to make it more feasible to directly compare the results.

The average weight of every subgroup shows the inconsistency in the data from the non-adhesive wipes. For the following experiments, the wipes will be cut in the manufacturing lab to ensure that the surface area is the same and the weight is as close as possible. Table I shows the amount of material collected by each trial experiment with both wipes. After concluding that sticky wipes collected more material than the non-sticky wipes, the proper combination of foam and adhesive material needed to be developed. Foam was included in the experimentation so that the material selected can contour to the shape of potential extrusions encountered on the surface. A second study was performed to find the right combination of materials. This study took place at ORNL.

**Table I. Mass Gain by Each Wipe Type**

Weight Gain Average (g) Adhesive		Weight Gain Average (g) Non-Adhesive	
Trail 1:	2.378	Trial 1:	0.665
Trial 2:	2.405	Trial 2:	0.662
Trial 3:	2.452	Trial 3:	0.665
Trial 4:	2.467	Trial 4:	0.663
Average	2.425	Average	0.664

Foam padding was the material selected for this application as it has excellent absorption properties. Foam materials of different configurations and thickness were chosen to be tested. Foams with adhesive properties were also included in order to enhance the collecting properties of the material. The selection of test surfaces was done in such a way that the selected areas for the experiment would represent the inside environment of a nuclear stack. When applying and removing the pad to and from the surface, the tension and compression forces were manually applied and measured with a spring scale. After every trial, the tension force required to retrieve the adhesive pad was recorded. This will allow for the selection of the electrical linear actuator. The compression force was kept constant at 13.34 N (3 lb). Some of the pad configurations were immediately discarded after the experiment due to the amount of force required to separate them from the surface. Normally, it is expected that a layer of dust could be on any given contaminated surface. However, hypothetically, the worst case scenario for which the highest amount of force is required to retrieve the pad is from a clean surface (dust-free environment). The recommendation was to create a breaking mechanism for the pad’s holder that would break and leave the pad on the wall if the linear actuator reaches its maximum force. Table II provides the data collected from the first experiment. From these results, it can be concluded that the linear actuator of 15.13 N (3.4 lbf) capacity used for the SCS’s smear sampler is adequate as long as a breaking mechanism is implemented on the pad holder. The break-away mechanism on the pad holder will prevent damage to the smear sampler in cases where the tension force to retrieve the pad exceeds the limit force of the actuator. The thick sticky pad configuration represented the best configuration for the smearing process; therefore, its use for the SCS’s smear sampler was recommended.

**Table II. Data Collected from Experimental Study at ORNL**

	Pad Type	Applied Force (Compression) N (lbf)	Applied Force (Tension) N (lbf)	Observation
Dirty Rough	R-Fa-R	13.34 (3)	9.34 (2.1)	Dirt Collected **
	TSP	13.34 (3)	7.56 (1.7)	Dirt Collected **
	$T_{sp}$	13.34 (3)	4 (0.9)	Dirt Collected **
Clean Smooth	R-Fa-R	13.34 (3)	15.12(3.4)	***
	TSP	13.34 (3)	44.48 (10)	***
	$T_{sp}$	13.34 (3)	45.82 (10.3)	***
Dirty Smooth	R-Fa-R	13.34 (3)	6.67 (1.5)	**
	TSP	13.34 (3)	11.12 (2.5)	***
	$T_{sp}$	13.34 (3)	23.13 (5.2)	***

R	Ribbon
TSP	Thin Sticky Pad
$T_{sp}$	Thick Sticky Pad
**	Removed Under 15.12 N (3.4 lbf)
***	Removed Over 15.12 N (3.4 lbf)
Fa	Foam

## SMEAR SAMPLING SYSTEM

The “smear” sampler is an automated mechanism capable of deploying 20 individual sample pads to check for removable contamination at a target location. The sampler uses an adhesive pad approach validated by FIU to be at least as effective as smear wipes at collecting removable contamination. The size and form factor of the pads is the same as currently used so that it will fit in the same Health Physics analytical equipment. The sample pads are arranged radially around the outer edge of a carousel and actuated in a manner such that only two actuators are required: one to rotate the drum and one to actuate the plunger. The design limits the pressure of the sample pad to the target to 3 lbs. There are detents in the plungers to permit the sample pad to sacrificially break away if it becomes accidentally attached to the wall. The same mechanism will be used to remove the samples from the plungers for analysis. The tray of 20 will be removed for analysis after the SCS is retrieved from the stack. The cover and shutter window protect the samples and minimize cross contamination concerns. The controls are external to the sampler itself but are contained in the bipod bay for the radiation instrumentation. Figure 3 shows the automated smear sampler mechanism with its cover and shutter window installed and also shows the shutter window opened and the sample plunger deployed to take a sample. The detail design phase for the automated samples has been completed. The prototype has been tested and final fabrication is in progress.

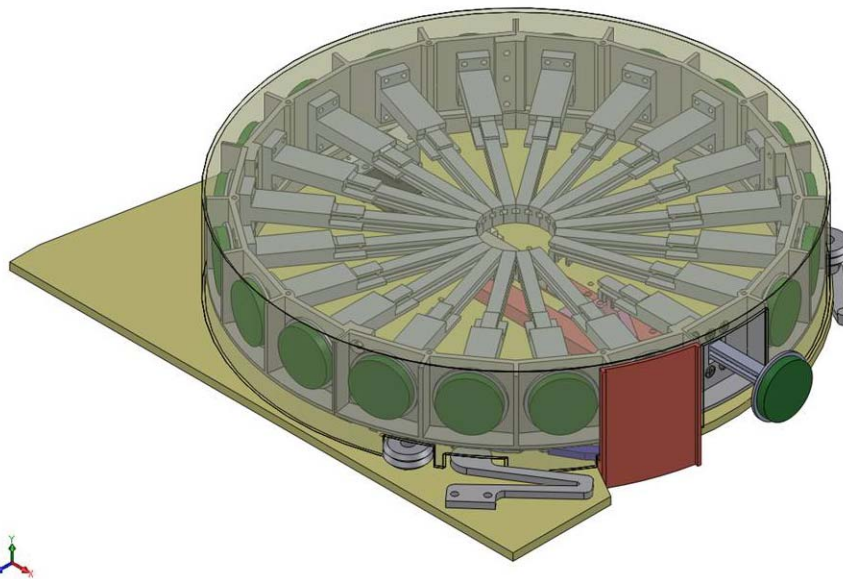

**Fig. 3. Smear sampling system.**

FIU interns (FIU students) performed tests at ORNL with the smear sampler. The first physical smear sampler was prototyped by the Robotics and Energetic Systems Group, Upgrades were made to the original prototype by FIU under the supervision of ORNL staff. Instead of using a rotational geared motor to rotate the carousel, another linear actuator was added. The actuator is located below the base. A detent was added at the base of the carousel as shown in the lower end of Figure 3. A detent is a mechanical component that prevents rotation. The detent was added to keep the carousel from rotating in the opposite direction and allow it to rotate forward only when the bottom actuator is energized. Testing of the prototype took place after the collection medium



was added to it. The collection medium, the double-sided adhesive foam tape, was added to the end of the push rods. For the preliminary testing, the adhesive sides of the pads were kept covered until it would be used for collection. The sampler and its base were mounted on a cart along with its voltage supply and the controller hardware (OPTO 22 PAC Controller), for preliminary testing of the design on outdoor surfaces. The original smear sampler prototype was tested on the same outdoor surfaces that the collection medium materials were tested on. Large grain particles were collected during the testing. One of the main objectives of the outdoor testing with the sampler was to observe if the actuator that extends the push rods with the pads would stall. The concrete block had enough surface particles to be collected by the sampler. As expected, the sampler did not stall when taking samples from the concrete block. The limit switch was tested during preliminary lab testing but was also tested again with the concrete block. Instead of allowing the push rod to extend out fully, an obstruction was set in front of it and the limit switch tripped the actuator to retract the rod as soon as it touched the obstruction. A semi-rough outside concrete wall was tested next; the outside wall did not have large particles but had much finer dust particles on it. The semi-rough surfaces also had enough particles to be collected by the sampler. Afterwards, the sampler was tested on a smoother concrete wall, the same results were yielded. The qualitative results yielded from the sampler testing proved that if there are any loose particles on the surface selected for sampling that:

- The adhesive pads would be able to collect it.
- The linear actuator would not stall.
- That the limit switch would retract the push rod if the full stroke of the actuator could not be accomplished.

The carousel on the sampler is meant to be transportable and meant to be an independent component of the sampler. With that stated, the carousel is meant to be removed from the base when the campaign is over and a new one is meant to be added for the next campaign. The sample pads will be removed from the carousel and analyzed for characterization. Because the carousel will be transported around, all the push rod stems need to be in their retracted position before it can be added to the base. The original carousel design was not able to keep the rods in without them sliding out when the carousel was being transported. Also, the rods have a circular cross section that allows the rods to rotate, making it harder for the linear actuator to extend the rod out. It was also noticed that the carousel itself did not have a location for the technician to pick up the carousel. The carousel design was the main objective to be completed during the summer internship as set by FIU and the Robotics and Energetic Systems Group. The first change made to the carousel was the cross section of the push rods. The circular rods were prone to rotating in place while the carousel was being moved. The new rods used a rectangular cross section. A support was also added to guide the rod and the rod has a slot on each side so that the support can act as rail for the rod. The rod also has a groove on the top surface; the support has an extruded circular section on it, the detent that fits into the groove on the rod. The detent prevents the rod from sliding out when the carousel is being moved. The support has a flexible cantilever end that is able to flex up and down as the groove on the support passed by it. If the detent is in the groove, the rod is not able to slide out until it is pushed forward by the actuator. The detent allows the rods to stay in their retracted position at all times until they are pushed forward by the actuator. The detent facilitates the transportation of the carousel. At the end of the stem, there is a cut out rectangular section. That cut out section allows the actuator to engage the stem when the stem is rotated in front of it and it also allows the actuator to push and pull on

the stem. On the opposite end of the stem, there is a disk that the adhesive pad sticks to. The adhesive pad is protected from cross contamination by the arced sections that make up the circle of the carousel.

Changes were also made to the disk pads but these changes were minor. The original rod design had a circular cross section; the new design uses a square cross section that reduces any rotation of the pad while a sample is taken. Because there is a change to the rod design, the disk pad design also needed to change. The new design has a detent built into it. The detents main purpose is to replace the pin that is currently being used to hold the disk to the rod. Previous testing of the adhesive pads with varying concrete surfaces showed that if a smooth clean surface is used, the adhesive pad could not be removed. The current design of the carousel does not prevent the sample pad from remaining adhered to a surface. In other words, the linear actuator provides 3.4 lb of pushing and pulling force and the pads are so adhesive that they will remain adhered to a dust-free surface, requiring more than 13.34 N (3 lb) of force to detach. The new rod and disk design does not require a connecting pin and will snap off if more than 11.12 N (2.5 lb) of force are required to detach the pad from the surface.

## **CORE DRILL SYSTEM**

The Robotics and Energetic Systems Group tested a commercially available core drill and designed their own with the data collected. The core drill for the SCS is a custom design with the capacity to do six cores in a single stack insertion. The cores are mounted on a revolving drum with a single drill motor and a linear actuator to extend the coring bits one at a time. Drill controls are local to the instrument bay dedicated to the core drill on the bipod. Initial core drill investigation and experimental work was done with a Shibuya Blu-Drill. Commercial drills used AC universal motors to power the drill. While these motors can be run on DC voltage, such as would be supplied by a battery pack, universal motors are not energy efficient and would be a problem in a battery-based system. The commercial designs were also not amenable to multiple cores. A custom design using energy efficient servomotors was selected. Required motor size was established through experimental testing.

The core drill assembly is shown in Fig. 4 and consists of a drill motor, a linear extend actuator, and a drum revolver actuator. The core drill bits are rotated on the drum to a single drill motor and drill extend/retract linear actuator. The drum rotates the desired core drill bit into position so that the drill motor and extend linear actuator engage the core drill drive interface. The linear extend actuator is force-based; a spring is used to engage the core break wedge when the preset force level is exceeded.

To prevent the spread of contamination, avoid cross-contamination of the core samples, and retain the core once the sample has been broken from the stack wall, a commercial HEPA vacuum system is used. The Blue Lake Products Omega Supreme Plus portable vacuum is packaged with the core drill in the drill instrument bipod bay as part of the system assembly. The vacuum motor is a universal motor. It runs on the DC battery pack and draws 3.2 amps maximum when running. The core drill bits are commercially available and will be procured on an as-needed basis. Several varieties will be tested during cold testing to optimize cutting ability.

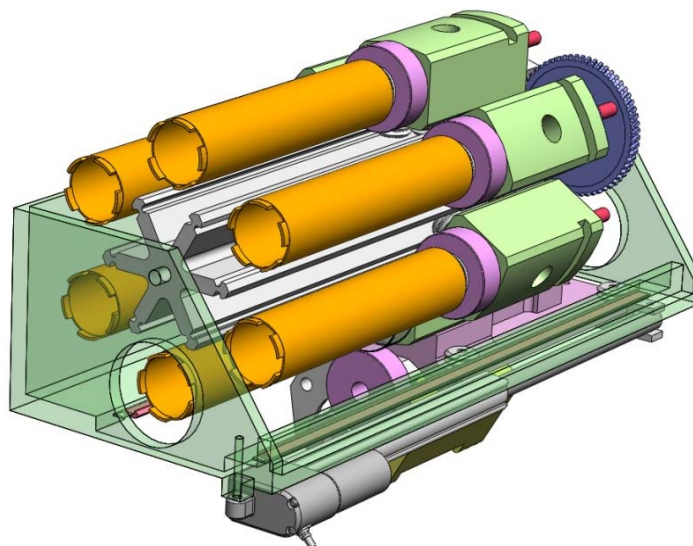

**Fig. 4. Core drill system.**

## **CONTAINMENT PACKAGE**

The SCS containment concept consists of a flexible collapsible bag in the shape of a cylinder with a base and top cover. The base is designed so that it centers on the top of the stack. The bottom of the SCS includes a disk that fits into the base of the bottom of the SCS containment to provide a bottom seal. The top of the SCS containment structure will be made of fiberglass to permit wireless communications through the structure. While the crane cable penetrates the fiberglass top, the opening is kept to a minimum to minimize the possibility of contamination outside of the containment package. As part of cold testing, ORNL will work with LANCS Industries to adapt the material used in their containment tents to the SCS containment task based on actual hardware. The focus and order of priorities will be on functional containment, durability, and minimum cost. Hot deployment of the SCS will require a trailer for transport and storage before and after each stack campaign. The trailer can also double as the operator station if it were divided into two sections.

There are no specific requirements that dictate the trailer design. The ORNL Work Plan system and ORNL Radiological Work Permit system will drive final design criteria. Consultation with ORNL personnel indicate that the primary concern is the ability to access the SCS while it is in its trailer for survey, decontamination, and sample recovery. A request was made that the interior surfaces of the trailer consist of smooth metal for decontamination ability. Constraints such as maintenance, equipment checkout, and post survey access to sampling equipment dictate that the SCS be stored and transported in a vertical position. The SCS is approximately 3.66 m (12 ft) high in its folded position. This places unusual constraints on the transportation trailer. Addressing the need to minimize permitting concerns for movement on site and/or public roads, the ORNL Transportation Management Organization recommended that the SCS trailer be no more than 2.6 m (8.5 ft) wide and less than 4.57 m (15 ft) high. Anything over 4.11 m (13.5 ft) tall will still require a special permit. To maintain these dimensions, a custom “low boy” trailer with a high ceiling in one section may be suitable. The top will have to open to lower the SCS in from the crane. The operator station portion of the trailer would be at normal height. If

additional metal needs to be added to aid decontamination ability, it may increase the trailer weight substantially.

## **CONCLUSION**

The design phase for the system is complete and construction of the system is planned to be completed by spring 2011. The overall design of the SCS was completed by the Robotics and Energetic System's group at ORNL and initial sub-assembly design for the radiation detector system was completed. After the ORNL group rapid prototyped the smear sampler, experiments were conducted with it to determine the effectiveness of the adhesive pads selected. After the experiments were conducted, minor modifications to the sampler were done to ensure that it would work properly during future cold testing. The ORNL group also completed a core drill design capable of retrieving six individual core samples in the event coring is needed on the stack. Future work for the system involves the containment package. FIU will design and construct a scale version of the containment system that will be tested to observe how it behaves on top of the stack when subjected to wind. In addition to the containment system, FIU will also work on designs for the trailer that will transport and house the SCS before and after each campaign.