

Sludge Retrieval from Hanford K-West Basin Settler Tanks - 11449

Eric G. Erpenbeck, CH2M HILL Plateau Remediation Company

Gregory A. Leshikar, AREVA Federal Services

Gary Hofferber, Vista Engineering

ABSTRACT

In 2010, an innovative, remotely operated retrieval system was deployed to successfully retrieve over 99.7% of the radioactive sludge from ten submerged tanks in Hanford's K-West Basin. As part of K-West Basin cleanup, the accumulated sludge needed to be removed from the 0.5 meter diameter by 5 meter long settler tanks and transferred approximately 45 meters to an underwater container for sampling and waste treatment. The abrasive, dense, non-homogeneous sludge was the product of the washing process of corroded nuclear fuel. It consists of small (less than 600 micron) particles of uranium metal, uranium oxide, and various other constituents, potentially agglomerated or cohesive after 10 years of storage. The Settler Tank Retrieval System (STRS) was developed to access, mobilize and pump out the sludge from each tank using a standardized process of retrieval head insertion, periodic high pressure water spray, retraction, and continuous pumping of the sludge. Blind operations were guided by monitoring flow rate, radiation levels in the sludge stream, and solids concentration. The technology developed and employed in the STRS can potentially be adapted to similar problematic waste tanks or pipes that must be remotely accessed to achieve mobilization and retrieval of the sludge within.

INTRODUCTION

Until 2004, the Hanford K Basins held the largest collection of spent nuclear fuel in the United States Department of Energy (DOE) complex. Between 2000 and 2004, 2,100 metric tons of spent fuel were cleaned, packaged, removed from storage in the K Basins, dried at the Cold Vacuum Drying Facility, and placed in interim storage at the Canister Storage Building.

A significant fraction of the K Basin fuel had degraded during its lengthy underwater storage period due to damage to the Zircaloy cladding sustained during reactor discharge and subsequent corrosion of the metallic uranium. The solids removed from the fuel elements during washing and cleaning discharged to an Integrated Water Treatment System (IWTS). The IWTS system included knock-out pots, fine strainers, settler tanks, and finally an array of garnet filters. Fuel washing products < 600 micron (sludge) in size were directed to ten large horizontal settler tanks. Inside the settler tanks, the tremendous increase in flow area causes a corresponding reduction in flow velocity allowing solids to drop out of suspension and deposit while traversing the settler tanks. Ultimately a total of approximately 3.5 m³ of sludge was deposited inside the tanks.

The IWTS Settler Tanks are shown in Figure 1. The array of tanks, oriented 5 high by 2 across, is 4 m tall by 1.2 m wide, and submerged in 5 m of water in the K-West Basin Weasel Pit. Each tank is 0.5 m (20 inches) in diameter and 5 m (16 feet) long. Each tank has an inlet port, an outlet port, and two 50 mm (2 inch) cleanout port pipe sweeps located near the bottom of each elliptical end cap. The cleanout port entries are oriented vertically and are located at three different heights. As can be seen in Figure 1, the narrow confines of the Weasel Pit significantly limited the placement and size of equipment designed to access the cleanout ports.

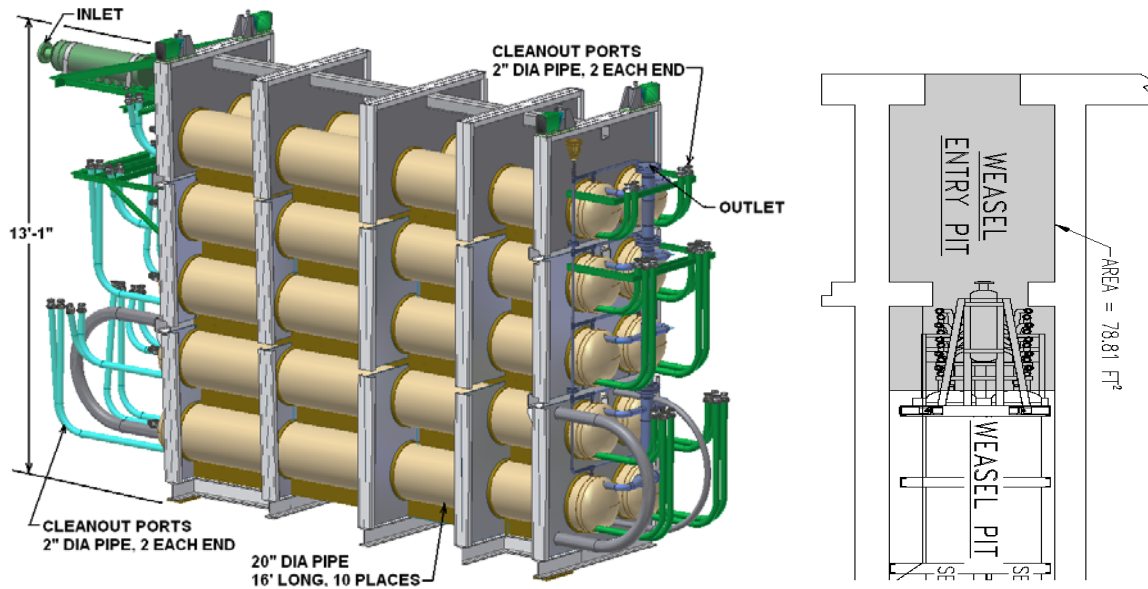

Figure 1. IWTS Settler Tanks

Process knowledge allowed for estimation of the settler sludge make-up. Obtaining sufficient samples directly from the settler tanks was determined to be prohibitive. Best estimate properties of the settler tank sludge were defined and a suitable sludge simulant was developed to allow for design analyses and testing to proceed. Table I shows typical sludge properties.

Table I. Estimated Properties of Settler Tank Sludge

Property	Value	Unit
Average Particle Density	6.0	g/cm ³
Settled Density	2.7	g/cm ³
Volume Fraction Water	67	%
Shear Strength	3650-6920	Pascal

Constituent	Weight % Dry	Particle Density, g/cm ³	Particle Size Distribution, micron
U-Metal	6	19	250-600
Large U-oxide	14	7.8	100-600
Fine U-oxide	68	7.1	Up to 250
Iron Phases	1	3	Up to 5
Aluminum Oxide & Blow Sand	11	2.2 to 2.5	Up to 250

RETRIEVAL CHALLENGES (CONSTRAINTS)

The retrieval of the settler tank sludge and the cleaning of the tanks for disposal proved to be a highly constrained problem. Evaluation of commercially available tank and pipe cleanout equipment was performed. This did not identify existing remotely-operated systems that could satisfy the unique combination of sludge mobilization and retrieval necessary along the full length of the settler tank, while addressing all the constraints.

Challenges to the retrieval mission included:

- Access restrictions to tanks.
 - Tank design and location. Physical access to the interior of the tanks was restricted to 50 mm (2 inch) ports submerged 1.5 to 4.5 meters underwater in a radioactively contaminated pool. The 90° elbow sweeps on the cleanout pipes restrict inserting a rigid tool into the tanks.
 - Congested area. The narrow Weasel pit, with hoses running through its doorway, is congested both above and below the grating, limiting the size of the retrieval equipment that can be staged inside it or above it. Per Figure 1, access to the east side tank cleanout ports is severely hindered by the back wall of the pit, while access to the west side ports is hindered by the pit walls and doorway.
- Maintain tank integrity. Due to the potential for future use of the settler tanks to support final processing of other K Basin waste streams, the tanks could not be damaged or significantly modified. Thus cutting the tanks or drilling holes to open up larger and more convenient access was not an option.
- Blind retrieval. Insertion and manipulation of the suction head and mobilization sprays inside of a settler tank must be performed without benefit of visual observation. Instrumentation is required to monitor progress.
- Personnel protective equipment (PPE) requirements. PPE including contamination clothing and powered air-purifying respirators are required during operations, hindering communication and limiting operator work times. In addition, industrial background noise greatly hinders verbal communication.
- Radiological Safety. Sludge filled hoses must remain at least 1 meter below water surface at all times when pumping.
- Minimal knowledge of sludge properties. The settled sludge had been in-place for 10 years and experience with other K Basin sludges indicated a real possibility that the sludge could be agglomerated/solidified or cohesively packed.
- Retrieval and transfer challenges with dense sludge. The uranium metal (spG = 19) and uranium oxide (spG = 7) constituents of the K Basin settler sludge require high transport velocities to be pumped successfully. This material is too heavy to “self-transport” out of the tanks simply by attaching a hose to a cleanout port and attempting to suck it out of the tank at a high flow rate. The retrieval system needs to entrain the sludge locally and keep it in suspension to its destination.
- Radioactive and highly abrasive transuranic sludge. Experience has shown that the K Basin sludge is extremely abrasive. Abrasion-resistant pumps and hose/piping is necessary.
- Retention of fines in destination container. K West Basin earlier completed final pass vacuuming and containerization of floor and pit sludges. Minimizing carry-over of solids out of the

underwater container during filling was a priority to avoid re-depositing the material on the basin floor forcing the need to re-vacuum the floors.

PROTOTYPE DEVELOPMENT AND SYSTEM DESCRIPTION

In 2008, prototype development and testing of retrieval equipment commenced at the project's test facility. A full-scale mockup of one settler tank was constructed, sludge simulants were formulated, and testing was performed to develop and optimize equipment for retrieving the sludge simulant. The retrieval system developed is shown schematically in Figure 2.

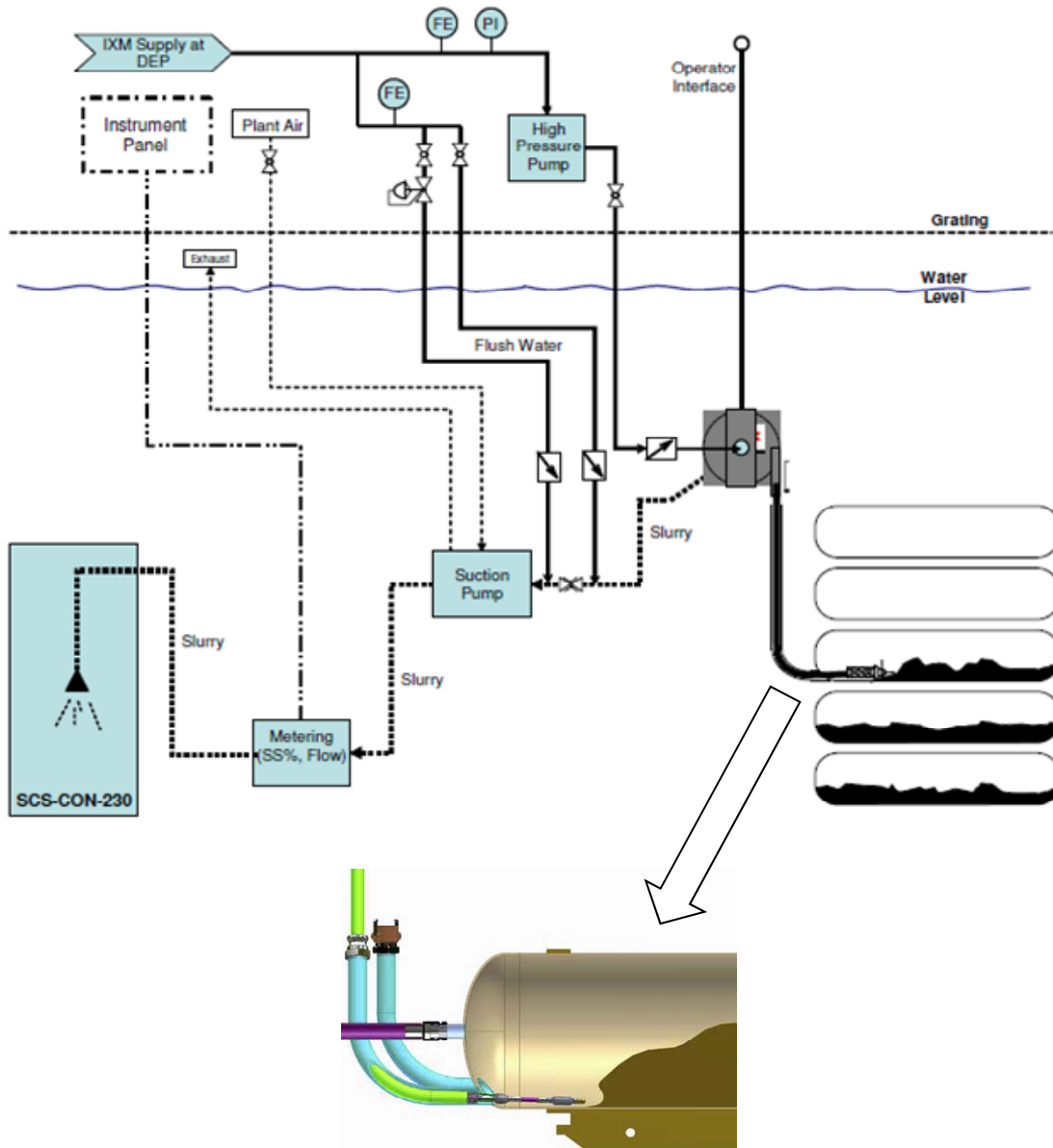

Figure 2. STRS Schematic and General Arrangement

System Description

A flexible Retrieval Head is manually inserted into a tank cleanout port and pushed through the 90° elbow using long pole tools. The Retrieval Head, with an orificed spray nozzle at its tip and a suction screen at its other end, is at the end of a 9 meter (30 foot) long coaxial hose consisting of a high pressure inner hose and outer suction hose. This hose is managed by a submerged Hose Reel to keep the slurry line beneath the water surface. Operators on the grating above extend or retract the coaxial hose using a handwheel connected to gearing on the reel. High pressure spray through the nozzle pulls the hose as the operator plays the hose out of the reel.

The cleaning process utilizes a high pressure pump to provide the pressurized water through the Hose Reel inner hose to the spray nozzle to agitate the settled sludge into suspension and provide the advancing thrust. Backward facing orifices “throw” the solids to the suction screen. A suction pump operates continuously to vacuum sludge into the suction screen and through the annular area between the inner and outer hoses. The suction pump conveys the slurry at 56 – 75 liters per minute (15-20 gallons per minute). An Instrument Skid containing magnetic flow meter, percent solids meter, and radiation probe are in-line to monitor the process.

A filtration scheme designed to maintain a negative flow into the destination container was developed and operated during the retrieval and discharge of sludge into the container. This system minimizes carry-over of fines into the basin water.

Key components of the Settler Tank Retrieval System (STRS) that resulted from the development effort are listed below and are described in more detail:

- Retrieval Head (suction and spray head assembly)
- Hose Reel with coaxial (hose-in-hose)
- Specially Configured Air Operated Double Diaphragm (AODD) Pump
- High Pressure Pump Cart
- Control System
- Destination Container Filtration System

Retrieval Head (Suction and High Pressure Spray Head Assembly)

Spray nozzles used for clearing plugged pipes are used commercially in the sewer/pipeline cleanout industries. Nozzles are readily available that are effective in mobilizing sludges and providing burrowing thrust to move a hose down the pipe. Typically, dislodged solids can be removed from a pipe simply by inserting a hose into the top of the pipe and pumping out at a high flow rate. However, because the combination of very dense sludge and large “pipe” diameter this approach cannot overcome the sludge settling velocity. As a result, a suction that is co-located with the sludge mobilization spray is needed.

Development focused on a Retrieval Head design that carried both the spray nozzle and the suction in one assembly. An iterative development and testing process with attention to all design constraints was undertaken to obtain a flexible Retrieval Head assembly. The resulting configuration is shown in Figure 3.

3. Key features of the Retrieval Head are:

- 1) Flexibility. The Retrieval Head must be able to pass through the 50 mm cleanout pipe 90° sweep. This is accomplished by design as segments of rigid parts linked by flexible parts as seen in Figure 3.
- 2) Spray Nozzle. Nozzles with various orifice sizes, angles, and numbers of orifices were tested to optimize both sludge mobilization and thrust to self-propel the head to the end of the tank. The selected commercial spray nozzle contains (13) 0.69 mm (0.027 inch) orifices [(4) facing backward at 45° angle, (8) facing backward at 25° angle to horizontal, and (1) facing forward]. The orifices are sized to operate at 200 bar (~3000 psi) to achieve maximum cleaning effectiveness. The high pressure water being ejected through the backward facing nozzles provides thrust to advance the Retrieval Head down the tank.
- 3) Stabilization Mass. This added mass prevents the head from veering off course, such that the Retrieval Head goes down the tank and doesn't curl upon itself when spraying.
- 4) Dilution Manifold. A small percentage of the high pressure water is bled off and directed into the suction screen as dilution water to reduce the potential for hose plugging.
- 5) Suction Screen. A stainless steel perforated screen with 0.64 cm (¼ inch) diameter holes is located approximately 40 cm (16 inches) behind the spray nozzle and connected to the outer coaxial hose. The inner high pressure water hose passes through a hole on the end of the screen. Development testing with sludge simulants showed that the backward facing orifices would “throw” the high density solids back to this location. Therefore the screen was located for optimal efficiency. Although there was not supposed to be any solids in the settler tanks greater than 0.64 cm in size, the potential existed for agglomerations that could plug the system if allowed to enter.

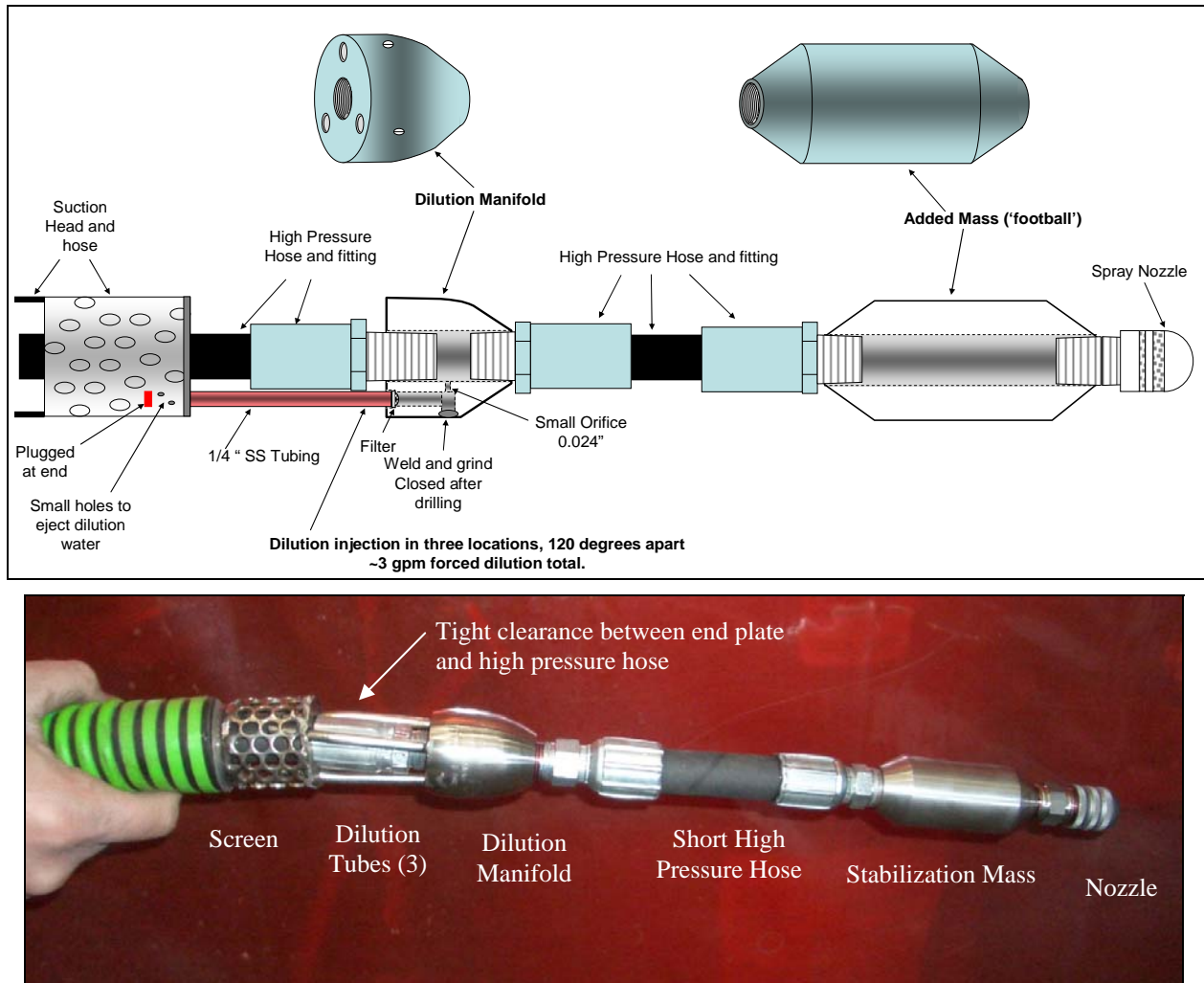

Figure 3. STRS Retrieval Head Design

Hose Reel with Coaxial Hoses

A custom, stainless steel Hose Reel was constructed to manage the coaxial suction/pressure hose underwater, and position the Retrieval Head inside the settler tank. An operator at grating level turns a handwheel to extend or retract the 9 meter (30 foot) coaxial hose with assistance from long pole tools as needed. As seen in Figure 4, the handwheel is connected to the Hose Reel by a mechanical flex-shaft. At the end of the flex-shaft is a worm that turns an 80 tooth, 20 cm (8 inch) pitch worm gear on the Hose Reel hub (80:1 speed reduction ratio). The hose reel has a 3.6 meter (12 foot) pipe welded to its enclosure top allowing it to be rigged and supported above the water while the slurry suction hose remains submerged. The reel was moved between settler tank cleanout ports using chain hoists above the grating.



Figure 4. Hose Reel and Handwheel

Other unique requirements for the Hose Reel design that were resolved during development testing were:

- 1) Combining a high pressure water supply line (fed from the basin grating) with the suction hose into the single coaxial hose within the hose reel hub.
- 2) A thin profile to maximize the ability to locate the Retrieval Head and hose directly over the settler tank cleanout ports in the crowded Weasel pit. Maintaining a small clearance between the reel plates and hose helps align the hose on the reel.
- 3) Providing a gear ratio that limits the ability to rapidly extend or retract the hose, thereby minimizing the potential for uncontrolled movement of the hose which could result in suction hose plugging.
- 4) Selection of outer hose to fit inside of the 50 mm (2 inch) cleanout pipe and flexible enough to turn the 90° sweep without binding. The hose also needed to be stiff enough not to “noodle” inside the settler tank. The exterior surface of the outer hose needed to have low resistance to friction.
- 5) Markings on the hose every foot to keep track of the Retrieval Head position within the settler tank.

Specially Configured Air Operated Double Diaphragm (AODD) Pump

Development testing with simulants validated the performance of a specially configured AODD pump with 1 inch inlet/outlet connections to transport dense solids from the settler tanks. Other pump types were considered, however the following important features led to the selection of an AODD pump:

- Ability to move fluids with high solids concentrations
- Non-clogging design utilizing check valves that function in the presence of solids. Top-down flow and porting that prevents heavy solids accumulation inside the diaphragm chambers.
- Low Net Positive Suction Head Required (NPSHR), necessary to accommodate the high frictional head losses within the annular area of the coaxial suction hose without overly cavitating the pump (AODD pumps are very resistant to cavitation damage).

- Low internal fluid velocities (compared to a centrifugal pump), minimizing wear from the highly abrasive K Basin sludge
- Simple variable flow control via compressed air supply pressure and air flow rate
- Submersibility of the pump with supply and discharge air hoses routed above grating
- No mechanical seals or electric motor

Testing showed the long coaxial suction line to cause large frictional losses which limited the flow rate to about 75 lpm (20 gpm). This essentially established the design flow rate for sludge retrieval and for the filtration system on the destination container.

Difficulties during testing revealed that several AODD pump models were unsuitable for the STRS application. Pump internal configuration was critical so that the high specific gravity particles will stay mobilized as they move through the pump chambers.

The AODD pump is shown in Figure 5. The selected pump, like many AODD pumps, is designed with the fluid inlet at the bottom and the fluid outlet at the top, such that the fluid must flow up through the pump. The trihedral style check valves permitted the pump to be oriented upside-down so the fluid moves down through the pump to help clear heavy particles from the pump chambers. Air operated valves and water flush connections accommodated directed water flushing forward through the pump and back through the Hose Reel to sweep away any solids deposited in the transfer line. Exhaust air from the pump was routed to a location a distance away to minimize consequences of a spray release of sludge in the event of a pump diaphragm rupture.

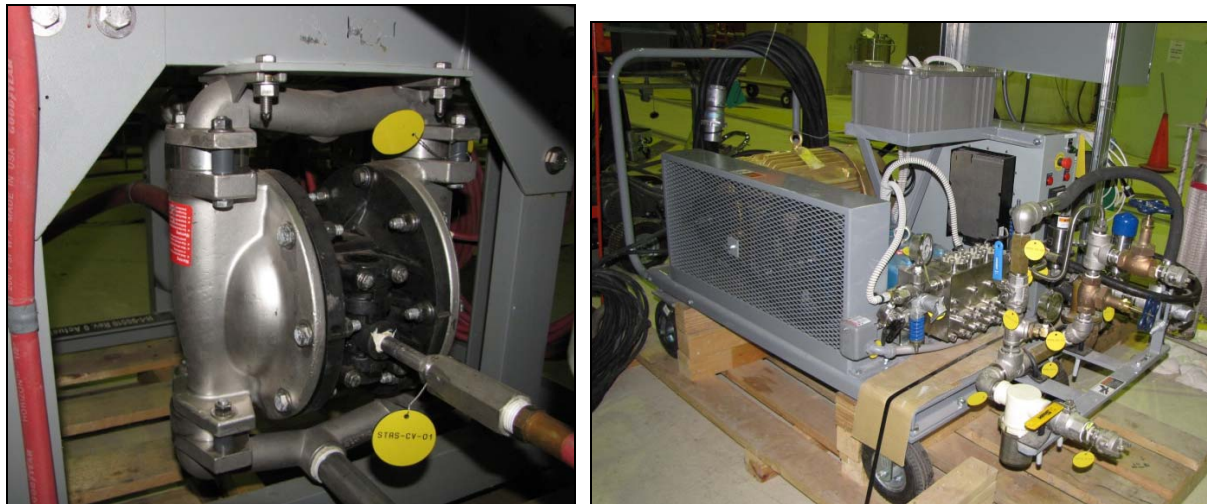

Figure 5. AODD Pump Mounted on Skid and High Pressure Pump Cart

High Pressure Pump Cart

A customized 30 HP high pressure pump cart containing a triplex plunger pump was procured to provide 200 bar (3000 psi) water at 50 lpm (14 gpm) to the Retrieval Head spray nozzle. The K-Basin de-ionized water system was used to supply clean water to the pump. A solenoid valve on the discharge of the pump could be controlled via the systems operator control panel to provide brief jets of water spray for solids mobilization. The cart contained a variable frequency drive that enabled two-speed operation depending on whether lower pressure “sparge” water (40 bar) or higher pressure “thrust” or “scrubbing” (200 bar) was desired.

Destination Container Filtration System

Figure 6 is a schematic of the innovative filtration system installed on receiving sludge container SCS-CON-230 to help prevent the escape of fine particulate onto the basin floor.

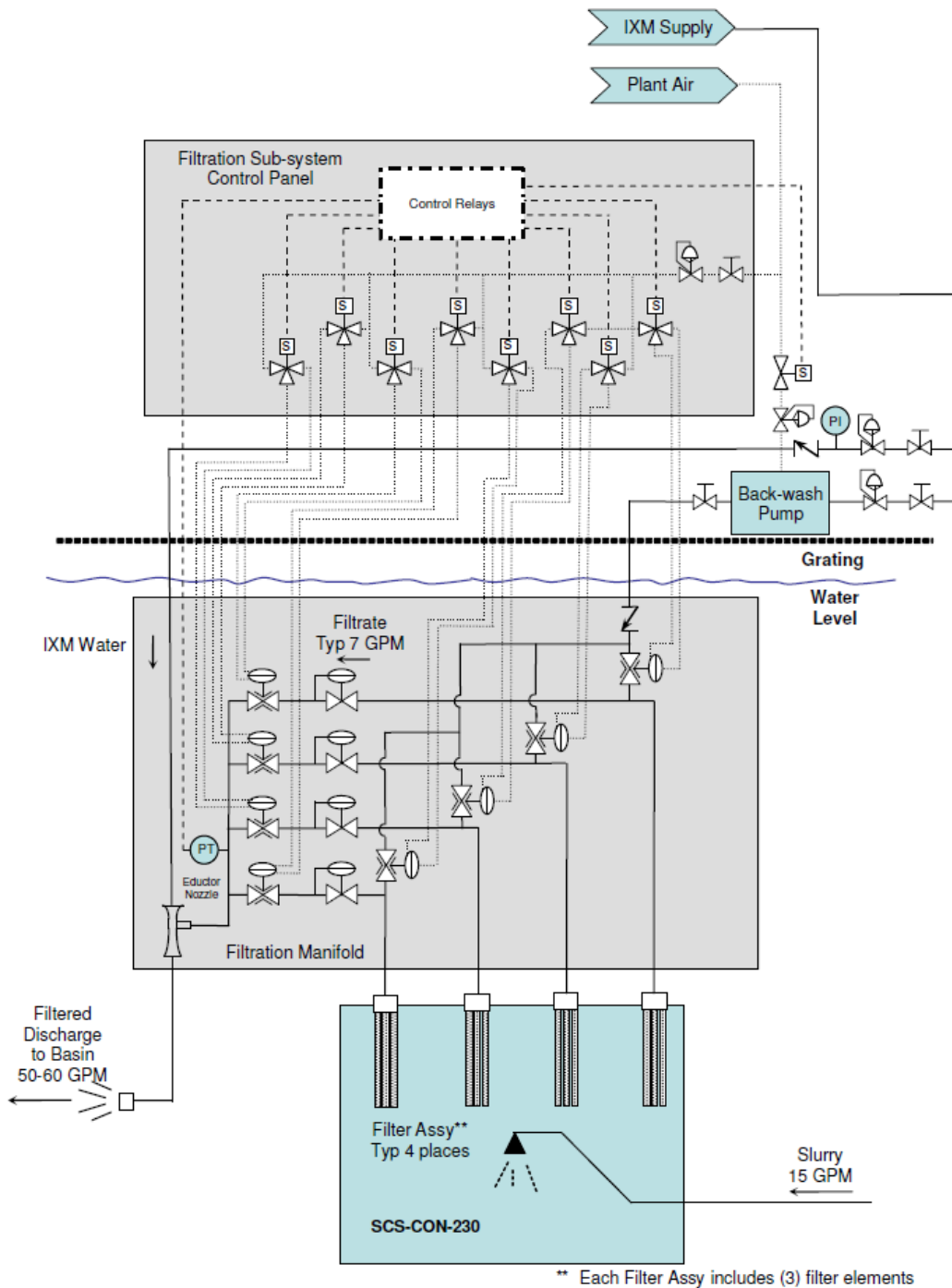

Figure 6. STRS Container Filtration System Schematic

As the container is being filled with retrieved sludge, water inside the container is filtered and discharged at a flow rate higher than that of the incoming sludge stream. By design, 106 lpm (28 gpm) of filtered water was discharged versus the 56-75 lpm (15-20 gpm) incoming sludge stream, with the makeup water coming from the basin pool into the container.

Each of the four filters inserted into the top of the container contained three 5 cm x 0.75 m long filter elements made of pleated stainless steel fabric and sized for particulates down to 5 microns. Suction through the filters was achieved an eductor installed outside the container, discharging the filtered water directly into the basin. When the eductor suction pressure fell below a preset value (indicating blinding of the filter elements), a short backwashing sequence (10 minutes in total) was automatically initiated to dislodge the filter cake.

The backwash utilized a modified AODD pump (pulsing from only one diaphragm) mounted on the grating supplied with clean water. The sequencing of the backwashing of each filter was achieved via a controlled operation of valves such that each filter assembly was individually pulsed for 30 seconds, followed by a 2 minute break to allow the released filter cake to disperse away from the filter. While one filter assembly was cleaned, the other three remained online.

Figure 7 shows the four filters installed on top of the destination container and hose connections to the air valve manifold vertically mounted on the side of the container under radioactive basin water.

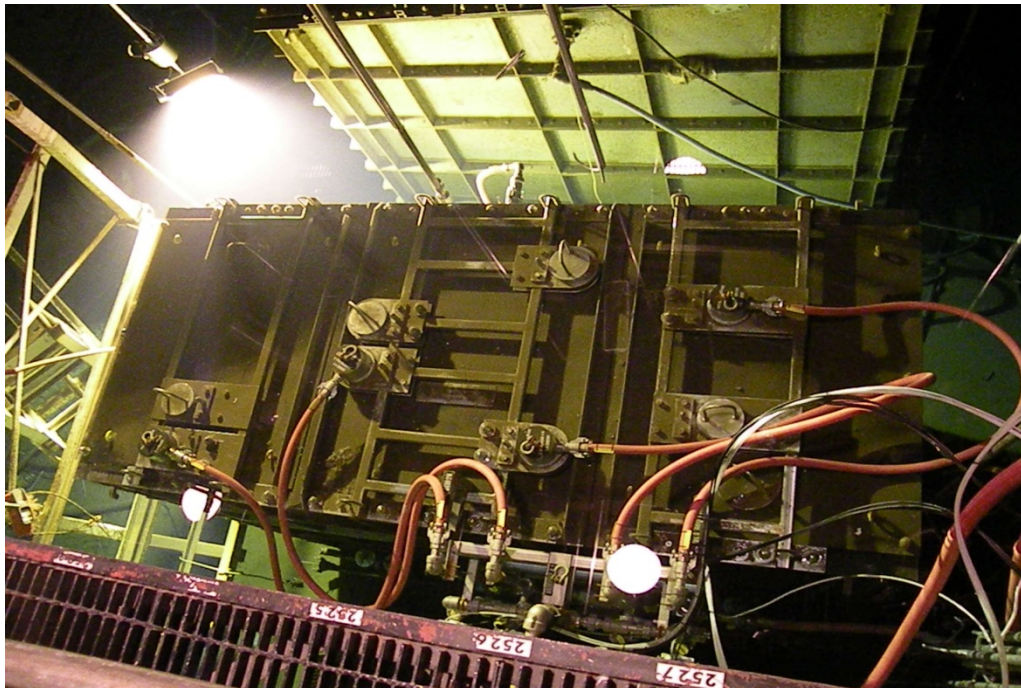

Figure 7 Destination Container with Filtration System Installed

OPERATING PROCESS AND PROCEDURE DEVELOPMENT

During prototype testing, a standard retrieval process and procedure was developed to methodically and efficiently remove sludge from a settler tank while operating “blind”. Without being able to actually see retrieval occurring inside the tank, the system operator had to rely upon a disciplined operation procedure and instrumentation for guidance, principally flow rate (via magnetic flow meter) and solids concentration (via % solids meter).

Figure 8 depicts the retrieval processes used during the operations phase of the project. First, bulk retrieval begins by manually inserting the Retrieval Head through the cleanout port and into the tank as the AODD pump is operated to clean out material encountered in the pipe. Once the Retrieval Head enters the settler tank it is pushed 0.3 meters (1 foot) forward, then slowly retracted 0.3 m (1 foot) back to vacuum the sludge near port opening. Once the monitoring shows that solids concentration has dropped, indicating that no more material is being motivated to the suction screen, the head is pushed 0.6 m (2 feet) forward and retracted back to the entrance, and so on until the Retrieval Head reaches the 1.2 m (4 foot) mark using manual methods for moving the hose. Note that high pressure water bursts are not initiated until this point because simulant tests identified that the jets would push material into the cleanout pipe and bind the coaxial hose.

At the 4 foot mark, a process referred to as the “5 x 1 Retrieval” is started as depicted in Figure 8. This process was designed to take a “bite” from the leading edge of the sludge bank and have the backward-facing nozzles on the Retrieval Head “toss” the mobilized sludge back to the suction screen. The head is slowly retracted after the “bite” to vacuum up the sludge between the pile and the cleanout pipe. This sequential process using the “5 x 1 Retrieval”, “Pole Tool”, and “Reel Back” techniques are methodically performed on a foot by foot basis to remove the bulk of the sludge from the settler tank.

When large amounts of heavy solids built up in the pump, the frequency of the pump beat (audible by operators near the exhaust housing) would slow and the pump would lug under the load. This could occur if the dilution water addition was insufficient to keep up with high retrieval rates, such as when material would ‘calve’ off and swamp the suction head. Generally a corresponding decrease in retrieval flow rate could be seen on the flow meter display. When this occurred, the operator would pause the retrieval and execute forward and reverse flush operations to clear the lines and the pump before continuing with the retrieval steps.

Continual monitoring of the percent solid readings allows the operator to know if the retrieval head was picking up significant amounts of sludge or not. If readings were very low (less than 2%) the operator would know to retract the suction head a few inches as part of the “5 x 1 Retrieval”.

Following the bulk retrieval (which removes around 95% of the solids from the tank), a series of additional passes were performed to sweep up as much of the remaining solids as practical. Two processes were established to do this. First, a “Scrub Run” that uses relatively long bursts of high pressure water to try to remove any stubborn material sticking to the tank walls. Second, a “Final Pass” that relies upon very slow retraction of the Retrieval Head, minimal water bursts, and extended pumping at the tank entry to remove suspended fines and clarify the tank.

Upon completing Bulk Retrieval, Scrub Runs and Final Passes, the tank is declared completed and the Hose Reel is relocated to the next cleanout port to clean the next tank. Typically it would take approximately 3 days to complete all runs in one settler tank, once the equipment was in position and ready for operation.

The destination tank filtration system was operated continually while the retrieval system was in operation to keep the fine sludge from carrying over into the basin proper. That system did not require continuous operator monitoring.

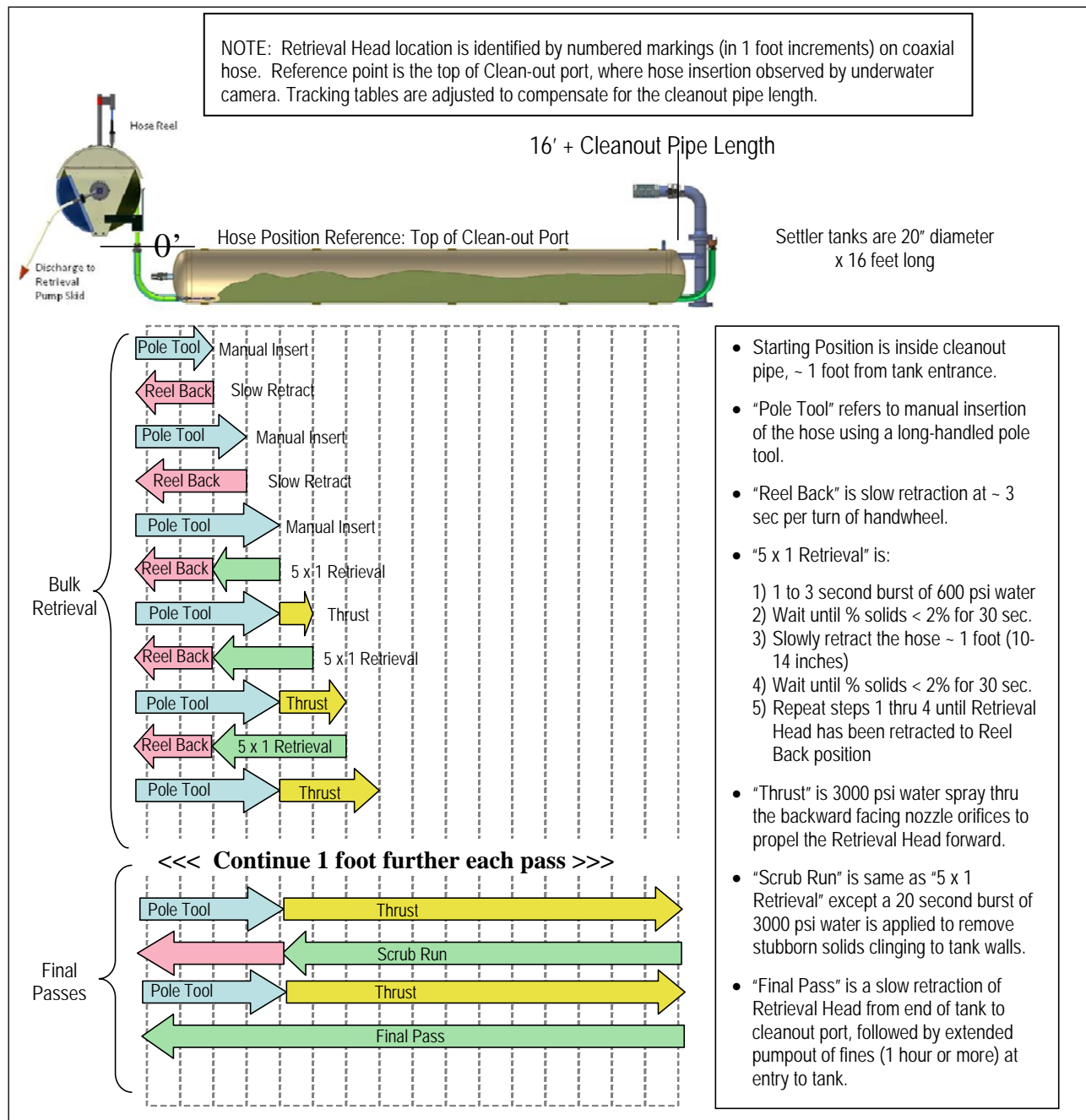

Figure 8. Bulk and Final Retrieval Processes

OPERATIONAL PERFORMANCE

Following full-scale qualification testing of the STRS equipment and operator training in the test facility, the system was installed in 105-KW Basin in late 2009 and operated through June 2010 to accomplish retrieval of the sludge from all ten settler tanks. The system performed very well, and without significant safety issues, cleaning one settler tank every 2 weeks on average taking into account the restrictions of working in a tightly controlled radioactively contaminated environment. The following are some field observations:

- Insertion and retraction of the Retrieval Head through the 90° cleanout pipe elbow with long pole tools was often difficult, especially during the first entry, but became easier as the operators improved their technique. The cleanout pipes were filled with granular solids up to the elbow (based on borescope inspections of some of the pipes prior to retrieval) which would hinder pushing the head around the corner. Fortunately, the material deposited inside the cleanout pipes was not hard-packed and the continuous pumping out through the suction hose would eventually clear the pipe and make insertion easier.
- The vast majority of the heavy material (uranium and uranium oxide) was located not far from the inlet to the tank (as expected). The initial high pressure water bursts would result in off-scale % solids concentrations and high radiation readings (3 R/hr outside the discharge pipe wall underwater), usually accompanied by audible lugging of the AODD pump and sharp decrease in slurry flow rate. Several times the flow rate did not recover, indicating a blockage in the line. Stopping the pump and performing water flushes successfully cleared the lines in each instance.
- Bulk retrieval of the back half of each tank (containing the lighter material) generally went without incident.
- Scrub runs and final pass retrieval processes did a very good job of removing residual fines from the tanks. Borescopic inspections showed most areas of the tanks to have only a light dusting of particles visible on the bare metal bottom of the tanks.
- Some overflow of sludge particulate from the cleanout port would occur during extraction as material caught within the corrugations on the outside of the suction hose would fall off. For future campaigns, this could be easily remedied by a wiper on top of the port.
- The destination container filtration system worked extremely well to minimize particulate outflow to the basin floor. Setpoint adjustments during the retrieval campaign successfully enabled the four filter assemblies to last through all ten tanks.
- The AODD pump was the only equipment to experience significant problems. The pump manufacturer's internal sealing design was inadequate to prevent compressed air from leaking into the process stream. The entrained air produced bubbles that gave false indications of solids on the % solids meter, and caused an intolerable amount of particulate overflow from the destination container as the bubbles "sparged" the suspended solids inside the container. The pump skid had to be replaced multiple times despite attempts to fix the pump design flaw.

Final borescopic inspections of the settler tank interiors revealed nearly all the sludge was removed, a total of only 6 to 9 liters of sludge was estimated to remain inside the ten settler tanks. Inspection of the receiving sludge container showed that approximately 3.5 m³ of sludge (99.7%) had been transferred.

FUTURE APPLICATIONS

Throughout the DOE complex similar cases have arisen where solids and/or radioactive wastes are trapped within difficult-to-access tanks, vessels, or pipes (submerged or not) that require removal. The Settler Tank Retrieval System is a simple-to-operate system that could be a preferred tool to effectively retrieve such material for these types of configurations and conditions. The remote operability of the custom Hose Reel in conjunction with the Retrieval Head is inherently desirable for underwater or radioactive conditions. The system can be fabricated and assembled from commercially available components and, if necessary, scaled up or down to other applications with additional design and testing.

More broadly, the STRS could be adapted to other applications as well. For example, an underground storage vessel or pipe filled with heavy or cohesive sludges. The retrieval system could be located on grade while the Retrieval Head is deployed down the access pipe to mobilize and suck out the sludge. Or the case of an above grade tank containing stubborn solids and limited by small access ports that restrict cleanout equipment insertion. The flexible Retrieval Head could gain entry to mobilize and remove the solids.

CONCLUSIONS

In summary, the STRS system successfully removed the difficult Settler Tank sludge in Hanford's K-Basin allowing the project to proceed with removal and treatment of all sludge streams and ultimately to demolish the facility. The technology employed in the STRS could be deployed as designed or potentially adapted to similar problematic waste tanks, vessels, or pipes that must be remotely accessed to achieve mobilization and retrieval of the sludge within. The advantages of the system can be summarized as follows:

1. The system can remotely enter and exit small access openings to tanks or vessels, and a wide range of pipe sizes. The Retrieval Head has flexibility to maneuver through sweeping corners.
2. The system can break up solidified sludges using high pressure water, then capture and transport highly abrasive solids having a wide variety of particle size distributions and very high densities.
3. The system can self-propel ("thrust") itself down a tank or pipe via ejection of high pressure water from backward facing orifices on the cleaning nozzle.
4. The system can be installed in relatively small and congested areas
5. The system can be operated underwater and/or in radioactive environments.
6. The system can be operated "blindly" (without visual observation of sludge retrieval progress) by relying on disciplined operation procedure and instrumentation for guidance, principally flow rate and solids concentration.
7. The system can be fabricated and assembled largely from commercially available components.
8. The system can minimize carry-over of solids from underwater destination containers via the innovative filtration system developed for that purpose.