

Shipment of Spent Nuclear Fuel from the Nuclear Research Institute Rez plc, Czech Republic to the Russian Federation for Reprocessing - 9422

J. Podlaha
Nuclear Research Institute Rez plc
Husinec-Rez 130, CZ 250 68
Czech Republic

ABSTRACT

After 50 years of operation of the research reactor operated by the Nuclear Research Institute Rez plc (NRI), a large amount of spent nuclear fuel (SNF) of Russian origin has been accumulated.

In 2005, NRI joined the Russian Research Reactor Fuel Return (RRFR) program under the US-Russian Global Threat Reduction Initiative (GTRI) and started the process of SNF shipment from the LVR-15 research reactor back to the Russian Federation (RF). SNF shipment from NRI to the Russian Federation represents a very complex and complicated scope of work, technically, legally and contractually.

The SNF shipment has been realized under several specific conditions:

1. High capacity ŠKODA VPVR/M casks were used for transportation for the first time, which enabled the shipment of both high and low enriched SNF (about 550 fuel assemblies) in one shipment, resulting in substantially reduced risk.
2. For the first time, high enriched uranium SNF from a research reactor has been sent to the RF from a European Union country under the appropriate intergovernmental agreements, legal regulations and conditions.
3. Combined road (ADR) and railway (RID) transport of the dangerous material was used, with several re-loadings of goods.

The following topics are described in the paper:

- The types of SNF from the LVR-15 reactor and the quantity of particular types.
- Experience gained during preparatory work for the SNF shipment.
- Experience gained during preparation and fulfillment of the frame contract between the US DOE and NRI, the contract between IAEA, ŠKODA JS and NRI to supply a transport and packaging system, and negotiations and contracts between NRI and respective subcontracting organizations in the Czech Republic, Russian Federation and transit countries Slovakia and Ukraine, to ensure the goal and schedule of the project were met.
- Experience gained during the legislative and legal process to obtain all licenses, permissions and agreements in the Czech Republic, transit countries Slovakia and Ukraine, and the Russian Federation, including the technical and financial support of the US DOE and IAEA.
- The transportation of SNF from NRI to the RF that took place in December 2007.
- The legislative and methodological aspects of the return of vitrified waste back to the Czech Republic.

Present and future NRI activities in support of SNF shipments from other countries are also discussed, from the point of view of the owner of the 16 high capacity ŠKODA VPVR/M casks, and from a supplier of some specific services.

INTRODUCTION

The Nuclear Research Institute Rez (NRI) is a leading institution in all areas of nuclear R&D in the Czech Republic. The NRI has had a dominant position in the nuclear field since it was established in 1955 as a

state-owned research organization, and subsequently developed to its current status. In December 1992 the NRI was transformed into a joint-stock company.

The VVR-S reactor started operation in 1957. The original EK-10 fuel was made up of rods of a 10 % enriched uranium dioxide-magnesium alloy in aluminium cladding. The fuel assembly (FA) consisted of 16 rods in an aluminium casing. The reactor was operated at 2 MWth maximum output until 1969 when the power was increased to 4 MWth. In 1974, IRT-2M fuel with 80 % enrichment was introduced. This consisted of 4 or 3 concentric square tubes of uranium/aluminium alloy fuel/metal clad on either side with aluminium. The power output of the reactor was increased to 10 MWth. In the years 1988 – 1989 the reactor was reconstructed into the LVR-15 reactor. This was essentially a complete rebuild of the reactor vessel and internals, primary circuit, control room and ventilation system. In 1996, IRT-2M fuel with 36 % enrichment using uranium dioxide was introduced. The maximum output of the LVR-15 research reactor is 10 MWth.

SNF is removed from the reactor core to the at-reactor (AR) pool. The spent FA is loaded into a cask standing on the top of the reactor and then a basket with FA is slipped on a slide into the AR pool. The SNF can then be transferred to the away-from-reactor (AFR) pool with the cask. After two years of cooling, SNF can be transported to an AFR pool located in the High Level Waste Storage Facility (HLWSF).

HISTORY OF SPENT FUEL MANAGEMENT

In the years 1969 – 1975, EK-10 SNF was transferred from the reactor site to temporary storage. SNF was held in dry storage drums (see Fig. 1). The SNF was then transferred to HLWSF between the years 1996-7. According to the storage period length, the character of the drum construction materials (carbon steel drum filled with concrete, carbon steel liner) and their possible interaction with aluminium cladding, as well as corrosion of the cladding had to be taken into consideration. It was decided to repack all EK-10 SNF into canisters.



Fig. 1. View inside one EK-10 storage drum after plug removal.

A new hot cell was built in HLWSF, and EK-10 SNF was repacked between the years 2006 and 2007 into stainless steel canisters, hermetically welded, put into a cask basket and then stored in a storage facility located close to the hot cell. Additionally, some leaked IRT-2M FAs were also repacked. Most of the IRT-2M SNF was moved out of the initial AFR pool in the reactor building into the HLWSF pool between the years 1996 – 2003. A ŠKODA 1xIRTM transport cask was used for each FA.

THE CZECH REPUBLIC'S PARTICIPATION WITHIN THE GTRI PROGRAM

The Czech Republic was included in the GTRI program in 2004. In 2005, the contract between the US DOE and the NRI was signed. Fig. 2 shows the structure of the GTRI program and the participation of the Czech Republic.

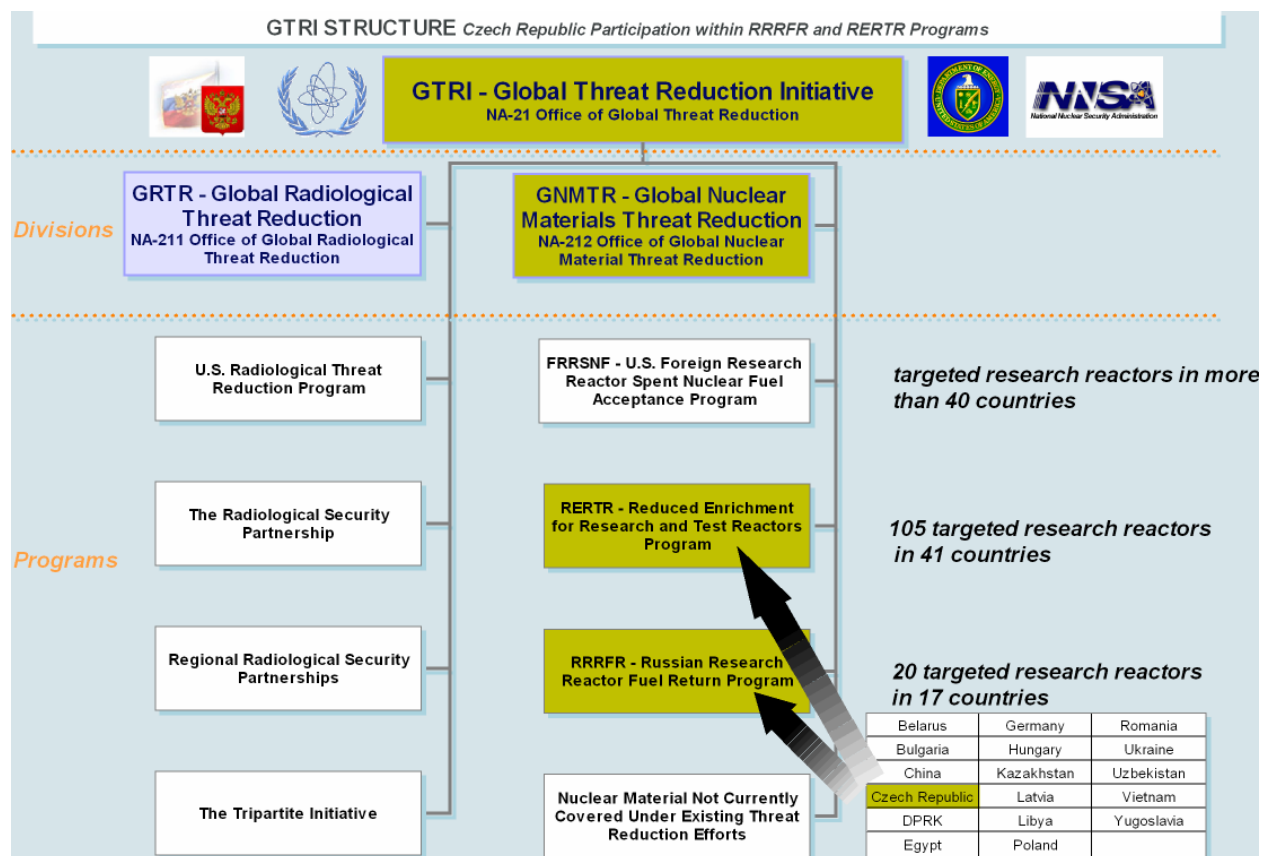

Fig. 2. GTRI structure and participation of the Czech Republic.

PREPARATION FOR THE SHIPMENT

The Czech Republic was included in the GTRI program in 2004. In 2005, the contract between the US DOE and the NRI was signed. Preparing and implementing the shipment of HEU SNF represent very demanding and highly professional problems requiring the cooperation of a number of organizations. With significant technical and financial aid from the US Administration and the US DOE (total of approximately CZK 450 mil.), the Czech Republic shall become a pilot country, which will carry out this shipment from the NRI to the RF by means of specially developed casks, which are compatible with the technology of research reactors of Russian design as well as the technology of the reprocessing plant in the RF.

Tender for such casks took place under the auspices of IAEA. Six well-known manufacturers from the USA, RF, Germany, France and the Czech Republic participated therein. The ŠKODA JS a.s. company was chosen as a supplier. Six ŠKODA VPVR/M casks were purchased by the NRI for shipment of low enriched (LEU) SNF; ten casks for shipment of high enriched (HEU) SNF were purchased by the US Administration (approximately USD 4 mil.) as a gift to the NRI, provided that the NRI make these as well as its own casks available for the RRRFR program. Once the shipment of SNF from the NRI has been carried out, all 16 casks will be further used for return shipments of SNF from other countries to the RF, by an agreement between the NRI and the US DOE, taking into account the NRI's experience preparing and implementing the transport from the Czech Republic to the RF.

In Table I. you will find a list of all contracts, agreements and licenses necessary for SNF transport and reprocessing.

Table I. List of activities (documentation, contracts, licenses)

	US DOE	Czech Rep.	RF	Slovakia	Ukraine	ESA
USA - RF GTRI Agreement	27-May-04		27-May-04			
NRI-DOE(NNSA) Contract	7-Mar-05	7-Mar-05				
CR-USA DipNote exchange	27-Apr-07	27-Apr-07				
CR-USA Min-to-Min Agreement	17-Sep-07	17-Sep-07				
Gov-to-Gov Agreement		04-Dec-94	04-Dec-94			
Gov-to-Gov Transport Agreement		14-Mar-98	14-Mar-98	14-Mar-98	14-Mar-98	
NRI – MAYAK Unified Project Contract		13-Jun-06	13-Jun-06			
Technical Conditions (Min Trans, Reg Body)		14-Sep-07	12-Oct-07	17-Sep-07	26-Oct-07	
NRI-TENEX Foreign Trade Contract		08-Aug-07	08-Aug-07			27-Aug-07
Package Design License		16-Feb-07	22-Dec-05	02-May-07	07-Aug-07	
Transport Permission		28-Jun-07	03-Aug-07	10-Aug-07	29-Oct-07	
CR-SK border physical protection exchange		27-Jan-04		27-Jan-04		
SK-UA border physical protection exchange				05-Oct-07	26-Oct-07	
UA-RF border physical protection exchange			12-Apr-96		12-Apr-96	
Agreement with Carrier		24-May-07	08-Aug-07	24-May-07	14-Aug-07	
Insurance for Nuclear Damage		28-Jun-07	08-Aug-07	28-Jun-07	28-Jun-07	
Czech Export License		28-Aug-07				
Russian Import License			30-Aug-07			
RF Governmental Decree			23-Nov-07			
Czech guarantee letter (RW return)		28-Aug-07				
Russian guarantee letter (nonproliferation)			21-Aug-07			
Transport technical documentation completed		17-Sep-07 NRI+DM S	17-Sep-07 NRI+MAYA K	17-Sep-07 NRI+DMS	17-Sep-07 NRI+IZOTO P	

Shipment	30 days before the scheduled shipping date MAYAK is informed about the shipment
-----------------	---

ŠKODA VPVR/M TRANSPORT AND STORAGE CASK

The ŠKODA VPVR/M cask (see Fig. 3) is a type B(U) and S cask system designed and licensed for the transport and storage of SNF from research reactors of Russian origin.

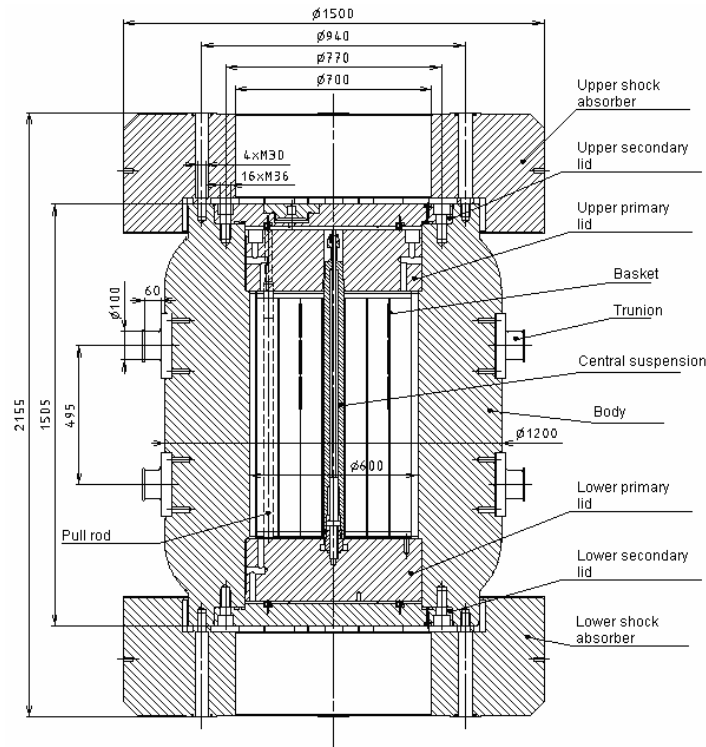

Fig. 3. Scheme of the VPVR/M cask.

The VPVR/M cask loading procedure is divided into the following activities:

- Cask transport to the SNF loading site, dismantling the cask
- Transport of the cask to the SNF storage facility (pool, hot cell)
- Putting the basket inside the loading facility (pool, hot cell)
- Loading the SNF into the basket, basket retraction into the cask
- Cask flushing with hot air, desiccation of the cask, cask completion, helium leaking test
- Cask sealing by IAEA and EURATOM seals

A specially designed basket handling tool is used for lowering the basket from the cask into the storage pool. The basket is filled manually with the FAs by a special manipulation rod. The crane and lift fixtures are equipped with a digital dynamometer that is used to monitor the weight of the basket during reinstallation into the cask. It prevents the disruption of the central suspension/hanger.

DEMONSTRATION OF SNF LOADING

The VPVR/M cask underwent three demonstrations to verify that the design was acceptable technically, for handling and loading SNF at the research reactor facilities, and for receiving and unloading at the

Mayak facilities in the RF. Demonstrations were held at the ŠKODA, NRI and Mayak facilities. The following sections provide a summary of those demonstrations.

Demonstration of the VPVR/M cask at the ŠKODA Manufacturing Facilities

The first demonstration was required by the DOE technical team to verify that the VPVR/M cask design was technically acceptable for use by the RRRFR Program. The demonstration was conducted in Pilsen, the Czech Republic, at the ŠKODA JS company. The demonstration included a leak test, cask manipulation operation, simulation of unloading the fuel basket at MAYAK, loading the SNF, and a demonstration of the accidental failure of the central suspension/hanger, resulting in the drop of the full basket.

Wet Run in the NRI Rez plc

The purpose of the NRI “wet run” was to: demonstrate that the handling equipment worked properly at the reactor site and at the HLWSF; demonstrate the detailed operating procedures; provide training for the NRI technicians; dry and seal the cask and prepare the cask for transport and loading into the ISO container. The “wet run” was observed by representatives from the USA, Ukraine, Poland, Russian Federation, Bulgaria, Slovakia, and various organizations from the Czech Republic.

Mayak Dry Run

The third demonstration was performed at the Federal State Unitary Enterprise (FSUE) Mayak Production Association facilities, in Ozyorsk. The purpose was to demonstrate the set-up of the cask handling and auxiliary equipment at the Mayak facilities; demonstrate that the detailed operating procedures were complete and operational; train the Mayak technicians; and perform cask maintenance in preparation for loading the empty cask for transport, loading it into the ISO container, tying it down, and returning it to the originating facility. The dry run was attended by representatives from the Czech Republic (NRI and ŠKODA JS), DOE, FSUE “Mayak”, “Sosny” R&D Company, and Rosatom.

PREPARATION FOR SNF LOADING

Preparation before the first cask loading included:

- Preparation of calculation and assembly data files for each FA and transmission to Mayak for acceptance (252 + 91 IRT-2M FAs, 206 canisters with EK-10 FAs / fuel rods).
- Preparation of documentation for loading and storage of the VPVR/M casks in NRI.
- Negotiations with the State Office for Nuclear Safety, IAEA and EURATOM about verification by their inspectors of the loading of FAs and cask sealing.
- Preparation of fuel and cask handling equipment and facilities for operations.
- Sipping test and visual inspection of all FAs.
- Preparation for installation of ancillary equipment, cask manipulations training.

LOADING SNF INTO THE ŠKODA VPVR/M CASKS

The SNF loading was performed in 2007. A specially designed cask transport carriage, which moves by rail, was used for loading operations at the reactor site. It serves for transferring the cask from the reactor hall to the reactor annex with a pool for SNF storage. Also, shielding above the pool was used during loading of the SNF, to protect the workers from radiation when the loaded basket was lifted out of the water and before it was completely inside the cask. Three casks were loaded at the reactor site with 91 FAs IRT-2M (36 %) and 10 FAs IRT-2M (80 %). The casks were then transported to HLWSF.

Six casks were loaded with 206 canisters with EK-10 FAs/fuel rods from the HLWSF hot cell. Seven casks were loaded with 242 IRT-2M (80 %) (235 FAs from the HLWSF pool and 7 repacked FAs from the hot cell). The casks were positioned into the pool onto the special platform. Loading the IRT-2M FAs was performed using a manual manipulation rod.

TRANSPORT OF SNF

Before transport, the transportation documentation had to be prepared and assembled and all necessary transport licenses had to be acquired. The transport of SNF from the Czech Republic to the RF took place across the transit countries of Slovakia and Ukraine by combined rail and road transport. The transport was performed in December 2007. The VPVR/M casks were loaded from the HLWFS storage area into the ISO containers (see Fig. 4). The ISO containers were transported to the railroad station on trucks and were then transferred onto the railroad carriages. Physical protection and emergency preparedness were ensured during transport.



Fig. 4. ISO container with the VPVR/M cask.

LEGISLATIVE AND REGULATORY FRAMEWORK

The preparation for transporting SNF to the RF included assuring compliance with a number of legislative and regulatory requirements contained in the Law on Peaceful Utilization of Nuclear Energy and Ionizing Radiation No. 18/1987 Coll., (the Atomic Act), and its implementing regulations, in particular:

- Decree No. 307/2002 Coll., on radiation protection as amended by Decree No. 499/2005 Coll.
- Decree No. 317/2002 Coll., on Type Approval and Transport
- Decree No. 144/1997 Coll., on Physical Protection of Nuclear Materials and Nuclear Facilities and their Classification
- Decree No. 145/1997 Coll., on Accounting for and Control of Nuclear Materials and their Detailed Specification, amended in Decree No. 316/2002 Coll.

Each of these regulations specifies what type of approval/decision is needed and which documentation must be submitted to the regulatory body. Some of these approvals are quite obvious and the process of obtaining them is well known. One license – a license for re-import of vitrified waste back to the Czech Republic - represents a challenge for both the NRI, as an applicant, and the regulatory body, as it will be the first time when an application of this type will be dealt with. According to the Foreign Trade Contract (FTC) between the NRI and Tenex such a license will have to be issued in 2026. While there is enough time for planning such a return, setting down requirements for the composition, physical parameters and properties of this waste was urgent, as the vitrification of waste will be done rather soon - in 2009. Pursuant to this, it was necessary to address the return of waste in the FTC very carefully with an assumption of extrapolating existing “legislation” to the period around the year 2025.

The fact that vitrified waste will have to be returned to the Czech Republic had been one of the basic conditions of the project. It was fixed in several clauses of the FTC and backed up by an explicit requirement from the Russian side – a commitment/guarantee of re-acceptance of the waste, to be confirmed by the authorized governmental body prior to signature of the FTC. The commitment on the return of waste from the reprocessing of SNF in the RF is also included in the Amendment of the Russian-Czech Intergovernmental Agreement on Co-operation in Nuclear Energy of 15.4.1999 (Coll. No. 154/1999), referred to in the preamble of the FTC.

The Czech side insisted on the condition that the return of waste will have to comply with legislation in both countries, understanding that this means both the legislation valid at the time of signing the FTC and the legislation which will be in place at the time of the return of waste to the Czech Republic. From a legal point of view, such a requirement was rather challenging, as it undermined the return of waste by something which was not yet known. The fact that the FTC was signed proves that both sides had realized, in the end, that the only realistic approach was to commit themselves to the fact that the return of the waste in 2026 would have to comply with standard international practices and valid legislation of both countries, regardless of what they might be.

The following three types of licenses condition the return of waste, according to existing legislation of the Czech Republic:

- a) A license authorizing re-import of the radioactive material recovered from SNF, exported from the Czech Republic for reprocessing
- b) A license for transporting a package with RAW through the territory of transit countries and the Czech Republic in compliance with current international safety standards
- c) A license for the package system, ensuring that the RAW to be returned, package type and sealing will meet the conditions of storage and handling up to the time of scheduled removal into the deep geological repository in 2065.

In order to obtain these licenses, the applicant will have to submit a number of documents specifying the nomenclature, composition, physical form, amount, package type, etc., of waste to be returned.

For the sake of avoiding any future misunderstandings and difficulties regarding the return of waste to the Czech Republic, both sides made maximum efforts to define the conditions of this return as far as possible and fixed them in the FTC. The FTC and its Appendices include additional regulatory requirements for the re-import of this waste, such as QA programmes for the vitrification process, instructions on the safe handling of vitrified waste, etc., all aimed at a smooth licensing process for re-importing the waste.

NEXT ACTIVITIES

The second shipment of the residue of HEU SNF from NRI (133 FAs) after changeover of the reactor operation to LEU fuel will be implemented in 2015.

Meanwhile, NRI participates in shipments of SNF from other countries within the framework of the GTRI program. NRI's participation consists of cask leasing, training of personnel in cask use and SNF loading, desiccation of casks and performing helium leak tests. In 2008, NRI participated in shipments of SNF from Bulgaria (3 casks) and Hungary (16 casks). Shipments from Poland and Ukraine are planned in 2009 and shipment of SNF from Serbia is planned in 2010.

CONCLUSIONS

All SNF has already been shipped to the RF. The contract between the NRI and the US DOE for NRI participation in shipments from other countries (Custodian Agreement) will continue. The second shipment of the residue of HEU SNF from NRI (133 FAs) after changeover of the reactor operation to LEU fuel will be implemented in 2015.

ACKNOWLEDGEMENT

We would like to thank the staff of all organizations involved in the project:

- United States of America (DOE – NNSA)
- IAEA, EUROATOM
- Russian Federation (Rosatom, Mayak, Tenex, Sosny)
- Ukraine (Izotop)
- Czech Republic (Nuclear Research Institute Řež a.s., ŠKODA JS, DMS)

Similarly, we would like to thank the staff of the state administrative bodies, ministries, and regulators in the Czech Republic and Russian Federation as well as in the transit countries Slovakia and Ukraine, who rendered their assistance to us in accomplishing the objectives of the project.

References

1. F. SVITAK et al., "Present Experience of NRI Rez with Preparation of Spent Nuclear Fuel Shipment to Russian Federation", The RERTR-2007 International Meeting on Reduced Enrichment for Research and Test Reactor, September 23-27, 2007, Diplomat Hotel, Prague, Czech Republic.
2. J. PODLAHA et al., "Spent Fuel Management at LVR-15 Reactor", 12th Annual Topical Meeting on Research Reactor Fuel Management (RRFM), March 2-5, 2008, Hamburg, Germany.
3. J. PODLAHA, "On the Experience of Utilization of New Casks ŠKODA VPVR/M", Workshop on "Technical and Administrative Preparations for Shipment of Russian-Origin Research Reactor Spent Fuel to the Russian Federation", May 21-23, 2008, Rez, Czech Republic.