

**Salt Processing through Ion Exchange at the Savannah River Site
Selection of Exchange Media and Column Configuration - 9198**

Renee H. Spires, Timothy Punch
Washington Savannah River Company

Daniel McCabe
Savannah River National Laboratory

Paul Taylor
Oak Ridge National Laboratory

ABSTRACT

The Department of Energy (DOE) has developed, modeled, and tested several different ion exchange media and column designs for cesium removal. One elutable resin and one non-elutable media were considered for this salt processing application. Deployment of non-elutable Crystalline Silicotitanate and elutable spherical Resorcinol Formaldehyde in several different column configurations was assessed in a formal Systems Engineering Evaluation (SEE).

Salt solutions were selected that would allow a grouping of non-compliant tanks to be closed. Tests were run with the elutable resin to determine compatibility with the ion exchange column configuration required for an in-tank ion exchange system. Models were run to estimate the number of ion exchange cycles required with the two resins in several column configurations. Material balance calculations were performed to estimate the impact on the High Level Waste (HLW) system at the Savannah River Site (SRS). Conceptual process diagrams were used to support the hazard analysis. Data from the hazard analysis was used to determine the relative impact on safety. This report will discuss the technical inputs, SEE methods, results and path forward to complete the technical maturation of ion exchange.

INTRODUCTION

SRS stores waste in 49 HLW tanks. The non-compliant waste tanks, those without secondary containment, must be closed by 2022 per the Federal Facilities Agreement (FFA) and the waste dispositioned by 2028 to comply with the Site Treatment Plan. Tanks cannot be closed without processing salt because every tank grouping includes salt tanks.

Currently, the bulk of salt processing will not begin before the startup of the Salt Waste Processing Facility (SWPF) in 2013. DOE has been improving the technical maturity of several alternatives for processing salt waste. One of these alternatives is a modular in-tank ion exchange process that could provide additional salt processing capacity, reduce program risk and reduce program life cycle cost.

SRS currently stores approximately 136 million liters (36 million gallons) of liquid waste in two Tank Farms, H-Area Tank Farm (HTF) and F-Area Tank Farm (FTF). Liquid Waste Operations (LWO) is tasked with the development, maintenance and implementation of the Life-cycle Liquid Waste Disposition System Plan (LLWDSP) (Reference 1). This plan provides the long-term operating strategy of the Liquid Waste (LW) System at SRS to receive, store, process, stabilize and dispose of the existing inventory of liquid waste, any future generated waste, and to close the associated tanks and facilities. As a critical part of the LLWDSP, SWPF is planned to begin operations in 2013 to process salt from the existing inventory of liquid waste.

To achieve the goals above, the LLWDSP follows a processing strategy of providing the tank space required to support meeting programmatic objectives and risk reduction by implementing several initiatives identified in the PBS-SR-0014 Risk Management Plan (RMP) (Reference 2). Previous SEEs identified and recommended the current technology of solvent extraction to be used for SWPF. During these studies, ion exchange processes were also identified and investigated as potential candidates for salt processing. Ion exchange provides a different salt processing technology as risk mitigation for space management. This SEE investigated the possible column configurations and media that may be used and recommended a path forward.

DISCUSSION

The LLWDSP forecasts that salt processing will drive the program life cycle. Several factors have contributed to this condition. Waste generation will continue beyond the year 2019. The waste currently stored must be dissolved and adjusted for processing in SWPF, resulting in a projected feed volume of 340 million liters (90 million gallons). In addition, the Programmatic Risk Assessment identifies 19 risks associated with salt processing. Ion exchange provides significant program risk mitigation for salt processing.

The salt solution feed modeled for ion exchange was salt from Tanks 1, 2 and 3 from F Area and salt from Tanks 37 and 41 from H Area. Processing of this salt solution feed would create tank space which is needed for SWPF feed preparation, 3H evaporator operation (to support sludge batch washing) and closure of Tanks in F Area. A diagram of an in-riser ion exchange process is shown in Figure 1.

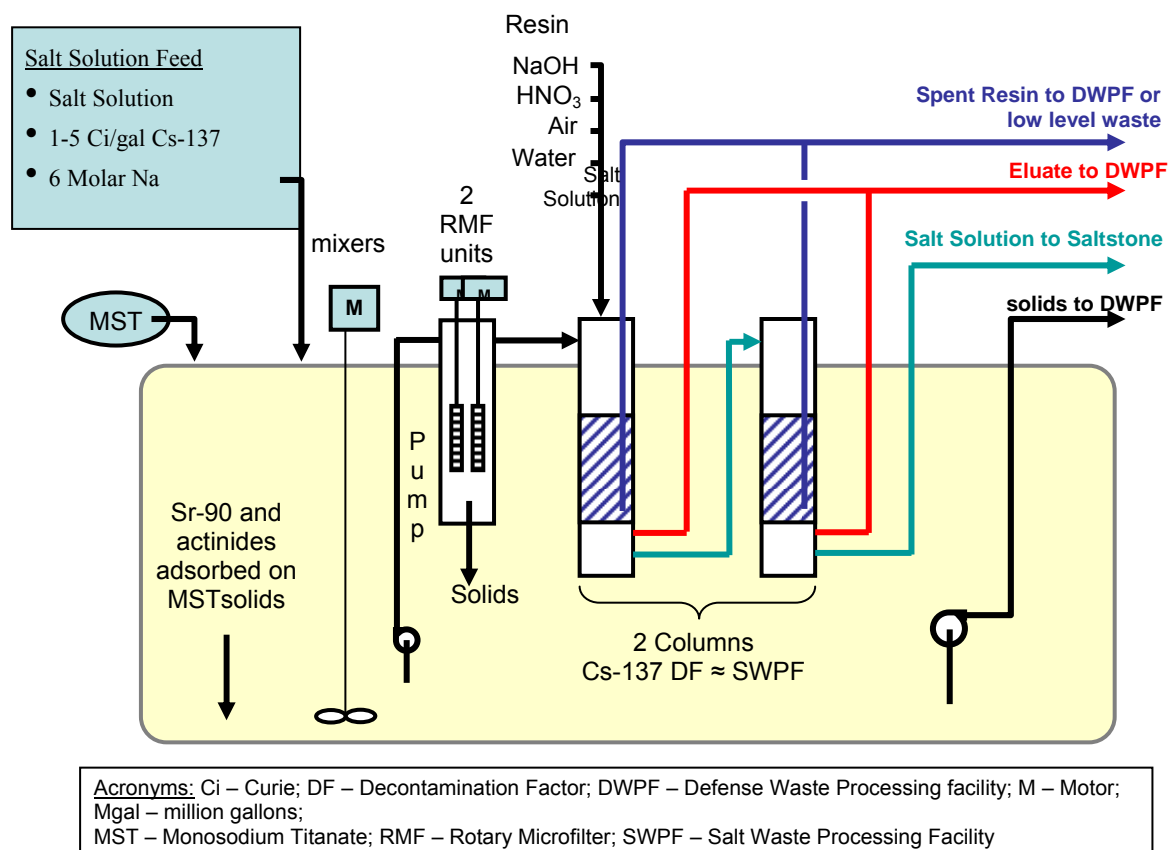

Fig. 1: Overview of in-tank ion exchange process

A team was assembled with the charter of recommending the most suitable ion exchange process, configuration and media. A Systems Engineering approach was taken in which options were first identified, screened for their ability to meet requirements and then evaluated to determine which option or options will be recommended for further development.

An SEE is a method used to select an alternative from two or more options which would be available to meet specific functions, selection criteria, and requirements. After identifying the functions, requirements and selection criteria, potential options are screened and then subjected to an appropriate evaluation process. The SEE process selected for this evaluation is the Analytical Hierarchy Process (AHP) methodology. This process uses “ratio values” in seeking a preferred alternative and is conducted using a software product, Expert Choice® Version 11, which is specifically designed for this application.

The SEE Plan shown in Figure 2 was developed and used to guide the process to completion:

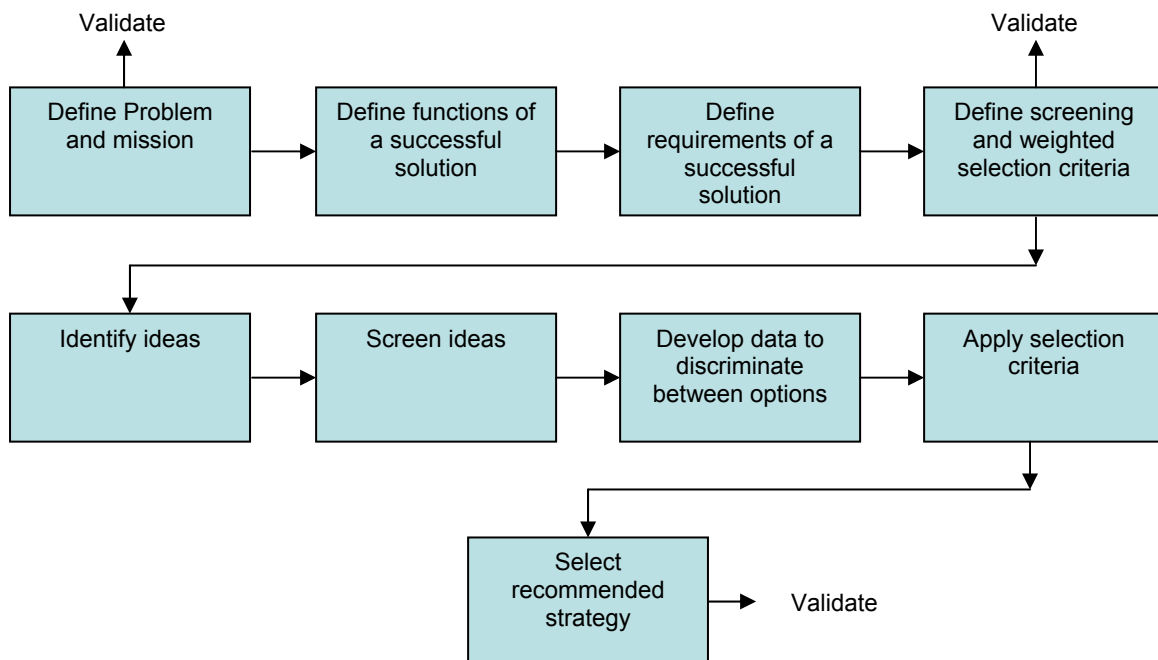

Fig. 2: SEE Plan

Mission

The first critical step in the SEE was defining the mission of the ion exchange process. The mission was defined by the Team and expressed as a series of goals as follows:

- Meet tank closure regulatory milestones in the FFA by providing tank space
- Minimize the quantity (curies) dispositioned in Saltstone Disposal Facility to be as low as practical

The charter of the Team was therefore to:

“Recommend the most suitable ion exchange (IX) process, configuration, and IX media for the mission.”

Functions

From the mission statement, the top-level function of “Process Salt Solution” was identified. The processing of salt solution using an ion exchange process allowed further definition of this function until the functional hierarchy (Figure 3) was developed. These functions were considered as the lowest level common to all potential IX options.

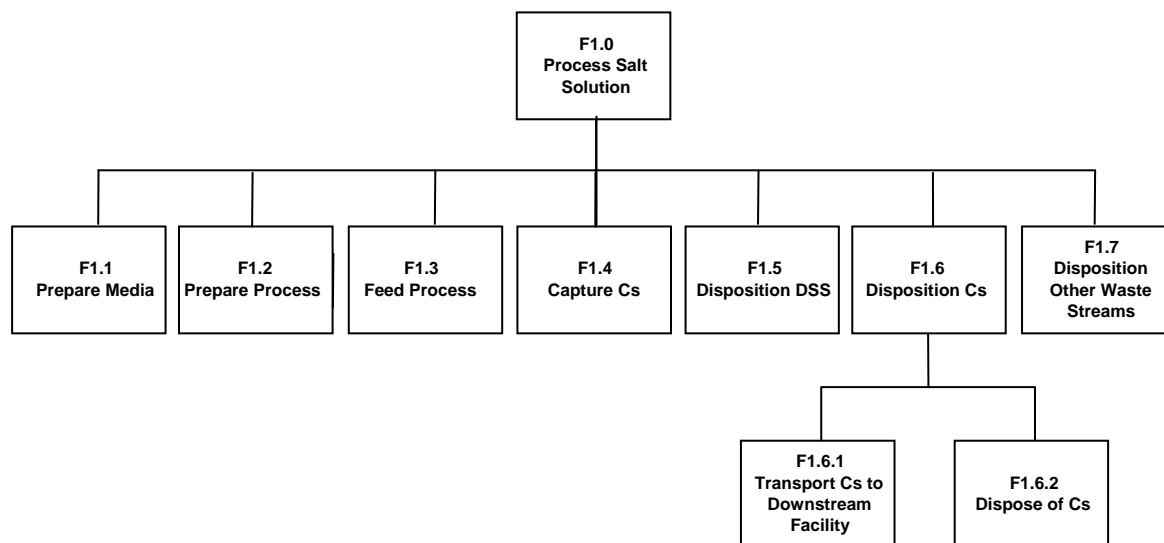

Fig. 3: Functional Hierarchy

Requirements

From the functions, performance requirements (PR) were outlined and where possible given definition:

F1.1 Prepare Media

- PR F1.1-1 Eliminate manufacturing and transportation residue
- PR F1.1-2 Prevent material degradation during handling
- PR F1.1-3 Disposition the residue

F1.2 Prepare Process

- PR F1.2-1 Ion exchange media must be chemically prepared (pH adjusted) without removing the column from the waste tank and without major maintenance activities (e.g., removal of column head, etc.)
- PR F1.2-2 New ion exchange media must be added (or replaced) to the column without removing the column from the waste tank and without major maintenance activities (e.g., removal of column head, etc.)
- PR F1.2-3 Media transport velocity must keep solids in suspension and not plug the piping.

F1.3 Feed Process and Capture Cs

- PR F1.3-1 Must process at an average rate of 9.1 million liters (2.4 Mgal/year)

F1.4 Capture Cs

- PR F1.4-1 Must support salt waste acceptance criteria requirement of 45 η Ci/g Cs-137

F1.5 Disposition Decontaminated Salt Solution

PR F1.5-1 When combined with the other material in Tank 50, the salt waste acceptance criteria must be met.

PR F1.5-2 Limit the discharge to <39 degrees C to Tank 50

PR F1.5-3 Combined with the other material in Tank 50, Safety Basis Requirements must be met.

F1.6 Disposition Cs and Spent Media

PR F1.6-1 Must support Downstream waste acceptance criteria.

PR F1.6-2 Media transport velocity must keep solids in suspension and not plug the piping (3-7 ft/sec for sludge).

PR F1.6-3 Particle size limit shall not exceed 177 microns (to meet DWPF sampler criterion).

F1.7 Disposition Other Waste Streams

PR F1.7-1 Spent caustic and flush water shall meet the requirements for disposal as industrial waste or be suitable for disposition during sludge washing to the evaporator system.

Identification and Screening

Initially, 26 options were identified. These options were screened using the performance criteria which resulted in some options being rejected and some options being combined to capitalize on their most favorable features. After screening, 12 options remained using two ion exchange media. These are the engineered form of Crystalline Silicotitanate (CST), and spherical resorcinol-formaldehyde resin (sRF). The CST was invented by Sandia National Laboratory and Texas A&M University. It is manufactured as an engineered material by UOP of Mount Laurel, New Jersey, with the trade name Ionsiv[®] IE-911. This material is not elutable. The other media, sRF, is manufactured by Microbeads AS of Skedsmokorset, Norway. This media is elutable with dilute acid.

The 12 options could then be placed into groups, those using crystalline silicotitanate (CST) media (Ionsiv IE-911[®]) and those using spherical resorcinol formaldehyde (sRF) media with the eluate either going directly to Defense Waste Processing Facility (DWPF) or to the 3H Evaporator system.

By grouping in this manner, pairwise comparisons could be performed during the evaluation for each group with the highest ranked options reviewed in a final evaluation. Grouping in this manner also assured the investigation and development of technical data could be done more efficiently. The options were grouped as shown in Table I.

Table I: Short List Options

Options	Title
	CST Ion Exchange Options
1	Single Column CST IX
2	Two Columns CST IX - Lead/Lag
3	Two Columns CST IX - Carousel
9	Two Columns CST IX - Series
	sRF Ion Exchange - Eluate to DWPF Options
5	Single Column sRF IX - Eluate to DWPF
6	Two Column sRF IX - Lead/Lag - Eluate to DWPF
7	Two Columns sRF IX - Carousel - Eluate to DWPF
10	Two Columns sRF IX - Series - Eluate to DWPF
	sRF Ion Exchange - Eluate to the 3H Evaporator
13	Single Column sRF IX - Eluate to the 3H Evaporator
14	Two Columns sRF IX - Lead/Lag - Eluate to the 3H Evaporator
15	Two Columns sRF IX - Carousel - Eluate to the 3H Evaporator
16	Two Columns sRF IX - Series - Eluate to the 3H Evaporator

Evaluation Criteria

The team developed evaluation criteria by consensus. Establishing evaluation criteria was based on the following desired criterion characteristics:

- Should differentiate among the alternatives
- Should relate to mission demands
- Should be reasonably measurable or comparable
- Should be reasonably independent of each other

A decision was made to develop evaluation criteria that met the above requirements and were important to the overall SRS mission and facility stakeholders. The Team acknowledged that both internal and external Stakeholders would be a major influence in decision-making; however, this approach evaluated options based largely on technical, quantifiable data which allowed Stakeholder preferences such as cost benefit to be evaluated after the pairwise comparison evaluations had been performed.

A second consideration by the team was that of schedule. Schedule was not used as a screening criterion. This ensured that all viable options would be identified and investigated without respect to schedule. This approach ensured potentially successful or even proven options were not screened out based on schedule concerns when they could be improved upon or be reasonably close to achieving mission goals. For this reason, schedule becomes a criterion for the evaluation phase.

Four Criteria were selected for the evaluation of options:

- Technical Maturity
- Compatibility to Downstream Processes
- Operational Complexity
- Schedule

During the investigation stage, data was developed on all of the options with respect to the evaluation criteria. To ensure that all the relevant information was obtained, a set of questions for each criterion were developed as shown in Table II. This set of questions was used to steer both the team and the subject matter experts enlisted to perform calculations and produce reports in support of the SEE.

Table II. Evaluation Criteria Guidelines

Evaluation Criteria	Definition
Technical Maturity	What additional R&D is required to deploy at SRS?
Compatibility to Downstream Processes	<p>Cs Stream How many canisters will be produced? What is the impact to DWPF throughput? What is the impact to sludge batch washing? What is the impact to sludge batch preparation? What is the impact to the tank farm? Are any legacy waste streams created?</p>
Operational Complexity	<p>Operations and Maintenance How many unit operations compose the process? What is the difficulty of operating the process? What are the interfaces with other facilities? Total quantity/type of cold chemicals? What is the difficulty in maintaining the process?</p> <p>Process Upset Recovery What are the possible process upsets and what are the consequences of these upsets?</p> <p>Safety Controls What are the safety controls for this process (# and complexity of interlocks and administrative controls)?</p>
Schedule	<p>Project Schedule What is the expected duration from the start of the project until the system is ready to operate?</p>
	<p>Processing Schedule What is the expected duration to process the material from Tanks 37, 41, and 1, 2 and 3?</p>

Each of the criteria was assigned a weight, agreed upon by team consensus. These are shown in Table III:

Table III. Evaluation Criteria Weights

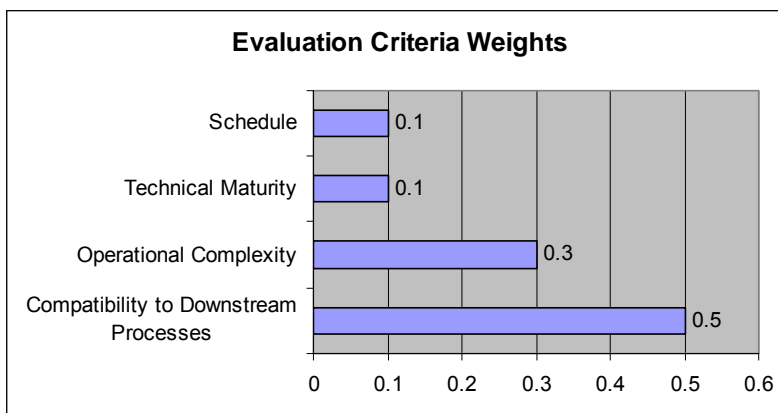

Compatibility to Downstream Processes

This criterion was considered the most important of all the evaluation criteria as the ion exchange process will have process interfaces with DWPF, Saltstone and HTF Storage and evaporation facilities. Any adverse impact to any of these facilities could seriously impact the ability of LWO to successfully execute the LLWDSP (Reference 1). Even relatively innocuous process flowsheet incompatibilities could slow downstream operations or require additional unit operations to rectify the problem. Creation of a secondary or tertiary waste with no clear disposition path would create the need for further handling or processing which could again impact the ability to execute the LLWDSP. Any throughput impacts would inevitably extend the lifecycle of the Liquid Waste Stabilization and Disposition Program. Any additional waste created for processing, e.g. additional saltstone volume, additional DWPF canisters etc., would also extend the completion of the Program. For these reasons this criterion was given a weight of 50%.

Operational Complexity

This second highest weight was assigned to operational complexity as the burden to operators can be a significant impact to overall operations when a process is complex and/or requires multiple unit operations or evolutions to be performed. Operating a process in a tank riser requires operator interaction and carries a potential for the operator to be exposed to chemical or radiological hazards. The simplest operations with a minimal amount of operator interaction are therefore more desirable.

Technical Maturity

A weight of 0.1 was assigned to technical maturity. The team considered that a high degree of technical maturity increases the confidence in a successful deployment. Technically immature processes when deployed prematurely have historically failed at great expense in the commercial industry as well as the government sector. Processes requiring research, development and piloting have also historically demanded more intensive efforts than originally anticipated to reach a deployable design state. As the technical maturity of the options being considered is relatively high, and their most important differences are primarily in downstream impacts, a weight of 0.1 was assigned, just below that of operational complexity.

Schedule

Although an important discriminator, this criterion was not considered by the team to be as important as the impact to downstream processes and operational complexity. However, it was considered as significant as technical maturity. The deployment of the project and processing the feed quickly will contribute directly to the ability to meet site treatment plan commitments. A short schedule to

deployment is therefore important to enable a benefit to be realized in the liquid waste disposition life-cycle.

These criteria and assigned weights were reviewed by the internal stakeholders and validated prior to completion of the evaluation process.

Investigation

Several studies and evaluations were completed to understand the capabilities and complexities of each option. The sRF and CST columns in lead lag were modeled with 45nCi/gram Cs-137 as an exit criterion. Material balances for both of these options were completed. This data was also used to understand the relative differences in column configuration .

Downstream impacts to sludge batch washing, DWPF Chemical Process Cell operation and DWPF Melter operation were considered carefully since this area constituted 50% of the score. Several options for managing the Cs stream were evaluated. For CST, the best option was to mix the CST in a sludge batch. For sRF, the best option was a direct transfer to DWPF. This still requires a new denitration evaporator for it to be considered a viable option. The nitrate from the 0.5M eluate causes the chemical process cell to become oxidizing and creates foaming problems in the Melter. Also, the nitrate largely returns to the Tank Farm in the form of condensate from the Acid Evaporator, requiring storage and eventual treatment in SWPF. Because of the complexity of the solution in DWPF, another option of sending the acidic eluate stream, after neutralization, to the 3H Evaporator system was also considered. However this option can only be implemented on a temporary basis to achieve much needed tank space. Although the salt solution is processed through Saltstone, the concentrated Cs stream is returned to the Tank Farm and must be re-processed to disposition the Cs. This also generates an appreciable amount of salt solution from the neutralized eluate stream.

Final Option Evaluation

During the evaluation of the options, engineering identified an optimization of the series configuration for sRF. This optimization resulted in a decrease in eluate that would make the series configuration as attractive as lead/lag. The Team decided to go forward in the final evaluation with the top CST option and the top two of each of the sRF options. This resulted in the following five options:

- Option 6-sRF Lead/Lag to DWPF
- Option 10-sRF Series to DWPF
- Option 14-sRF Lead/Lag to 3H Evaporator
- Option 16-sRF Series to 3H Evaporator
- Option 2-CST Lead/Lag

Results

The options were then reviewed in a pairwise comparison process using the evaluation criteria with the following results:

Compatibility to Downstream Processes

CST in the lead/lag configuration was considered the most compatible of all of the options with respect to the current HLW flowsheet. CST had minimal impact on the sludge batch qualification, very little or no known impact on DWPF Chemical Process Cell operation and very little impact on glass quality. sRF in series configuration to the 3H Evaporator had no impact to DWPF. However, this would only be a temporary solution to create tank space, since the Cs curies would require re-processing. The additional spent media generated also contributed to lowering the sRF score compared to CST. With the optimization to the elution of sRF in series, the elution volume was less than sRF in lead/lag, so sRF in

series scored slightly higher. The impact of sRF eluate on DWPF processing was significant. A transfer line and a de-nitration evaporator with ancillary systems are required to make this option viable.

Operational Complexity

Setting up the cold chemicals, performing the elution steps and loading out the spent media for all the sRF options were determined to be more operationally complex than CST Lead/Lag. Among the sRF options, changing the column positions for lead/lag was generally more complex than the series configuration. There was no operational difference in transferring the eluate to DWPF versus an evaporator. For these reasons, CST received the highest score.

Technical Maturity

The amount of R&D required for sRF to DWPF was more than sRF to the 3H Evaporator. For sRF to DWPF, a denitration flowsheet will have to be developed. CST Lead/Lag was significantly less than that required for all sRF options; therefore, CST scored high in technical maturity. The column configuration did not contribute to R&D requirements with any of the options; however, with the sRF options, final destination of the eluate stream favored 3H as the more technically mature.

Schedule

The project schedule for CST Lead/Lag was significantly shorter than the project schedule for any of the sRF options. This is due to the scope required to ensure compatibility with downstream processes e.g. denitration for DWPF options, transfer line and additional R&D for RF options. The minor differences in the processing time contributed to the minor differences in scores among the options.

Synthesized Scores

Table IV. Final Options - Synthesized Scores

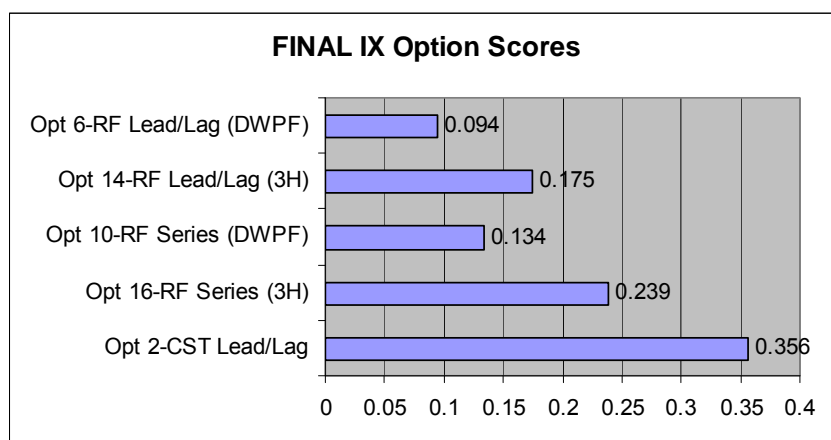

The CST in Lead/Lag dominated all the evaluation criteria scoring and therefore scores highest overall as shown in Table IV. The amount of information available for incorporating CST in the HLW flowsheet overwhelmed the amount of information available for sRF. This uncertainty was manifested in longer project schedules, lower technical maturity and increased scope to ensure compatibility with the flowsheet. sRF is more operationally complex because of the additional processing steps required to elute the media.

Cost Benefit Analysis

A cost benefit analysis was performed for all the final options. Data was assembled for all of the options

relative to project cost and operating (life cycle) costs. The cost of each of the final options was obtained and then each option expressed as a fraction of the total cost of all the final options added together. This essentially normalized the costs for each of the final options. These results are shown in Table V.

Table V. Normalized Costs

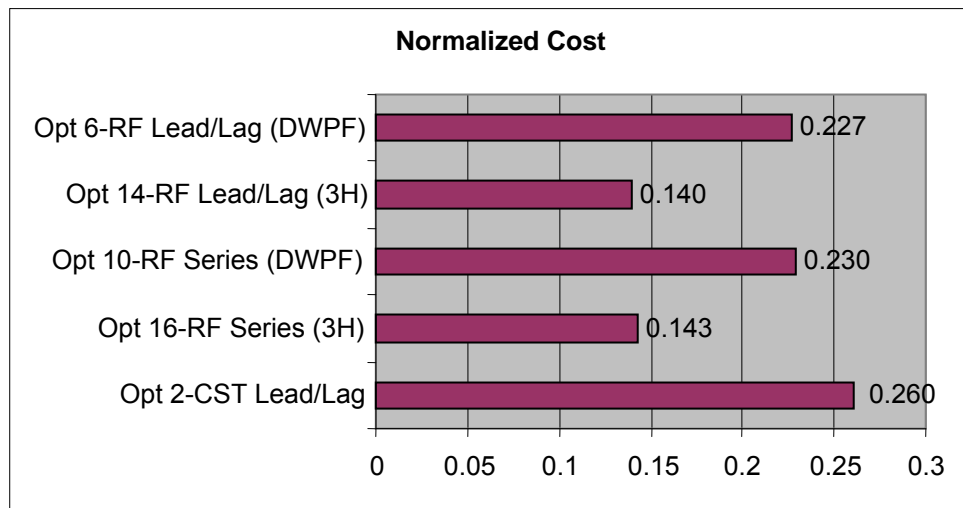

CST Lead/Lag can be seen to be the most expensive (due to the cost of the media and the additional canisters at DWPF) and sRF Lead/Lag the least expensive, with the other final options falling between the two. To derive a cost benefit ratio, the actual score of each option (benefit) was divided by the normalized cost of that option. This is shown in Table VI.

Table VI. Cost Benefit Ratio

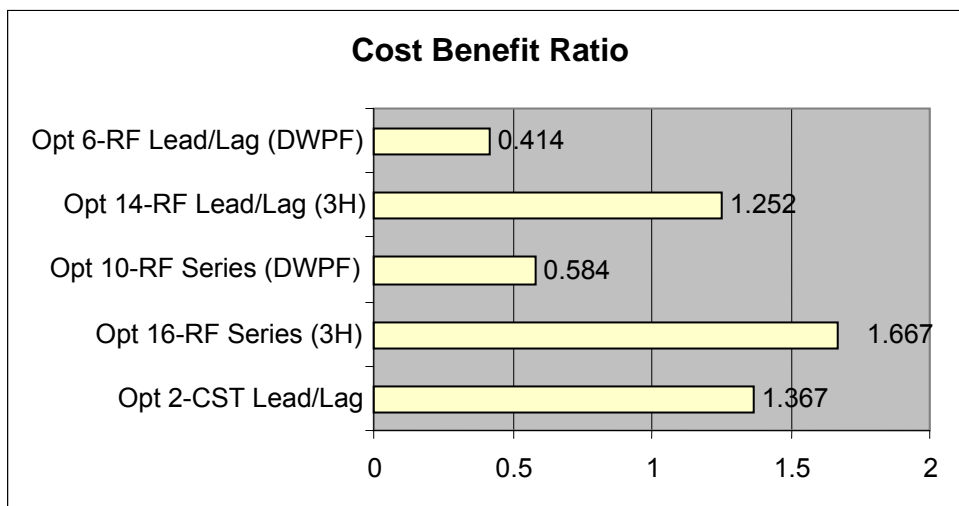

The cost benefit ratio for sRF series column configuration (Option 16) is better than CST lead/lag (Option 2). This is basically due to the cost of the media and the additional canisters at DWPF. However, sRF to the 3H Evaporator can only be implemented as a temporary solution to improve Tank Farm space because the Cs curies are not dispositioned. The cost benefit of CST in a lead/lag configuration becomes more favorable in comparison to sRF to 3H or DWPF as a long term solution.

Recommendation

After evaluating these options, performing a cost benefit analysis and assessing major risks, the Team would select CST in a lead-lag configuration (Option 2). The knowledge base for CST is more complete than sRF; however, sRF will have many desirable attributes should it be successfully matured. Therefore, during the technology maturation phase of this effort, the Team recommends continuing development of both media for LWO applications until the DOE is ready to initiate a project. The driving considerations to the final decision will be the impact of increased canisters from CST, chemical process cell impacts from sRF on DWPF and any remaining technology maturation issues. The logic to develop the technology is shown in Figure 4.

Crystalline silicotitanate removal of Cs has been tested and proven. The risks remaining for this technology can be mitigated with the appropriate studies and testing. The one major issue remaining for CST is the impact on lifecycle costs due to additional canisters. A 25% reduction in the additional cans from CST represents the break-even point for cost in comparison to sRF. A project to implement the CST option could be implemented at any time as long as the additional canisters can be accommodated in the lifecycle plan.

Resorcinol formaldehyde removal of Cs eliminates the lifecycle impact associated with additional canisters. However, there are major impacts on the DWPF flowsheet from the acid eluate stream. Some of these impacts are similar to the impacts for the ARP/MCU and SWPF strip effluent stream; however, the higher acid concentration does pose increased risk and cost. An investment in improving the compatibility of the sRF eluate with DWPF and in improving the ability of the tank farm to accommodate an acid stream could change the recommendation to favor sRF. Work is in progress to reduce the impact of sRF on DWPF by changing the eluant or reducing the nitric acid concentration in the eluant. Early implementation of sRF at SRS could provide benefit to Hanford, since sRF is the baseline process for the

WM 2009 Conference, March 1-5, 2009, Phoenix, AZ

Hanford Waste Treatment Plant. If the compatibility with DWPF can be improved sufficiently, then the project could be implemented to send the sRF eluate to an evaporator system on an interim basis. This strategy would accelerate salt processing, while the modifications at DWPF are implemented.

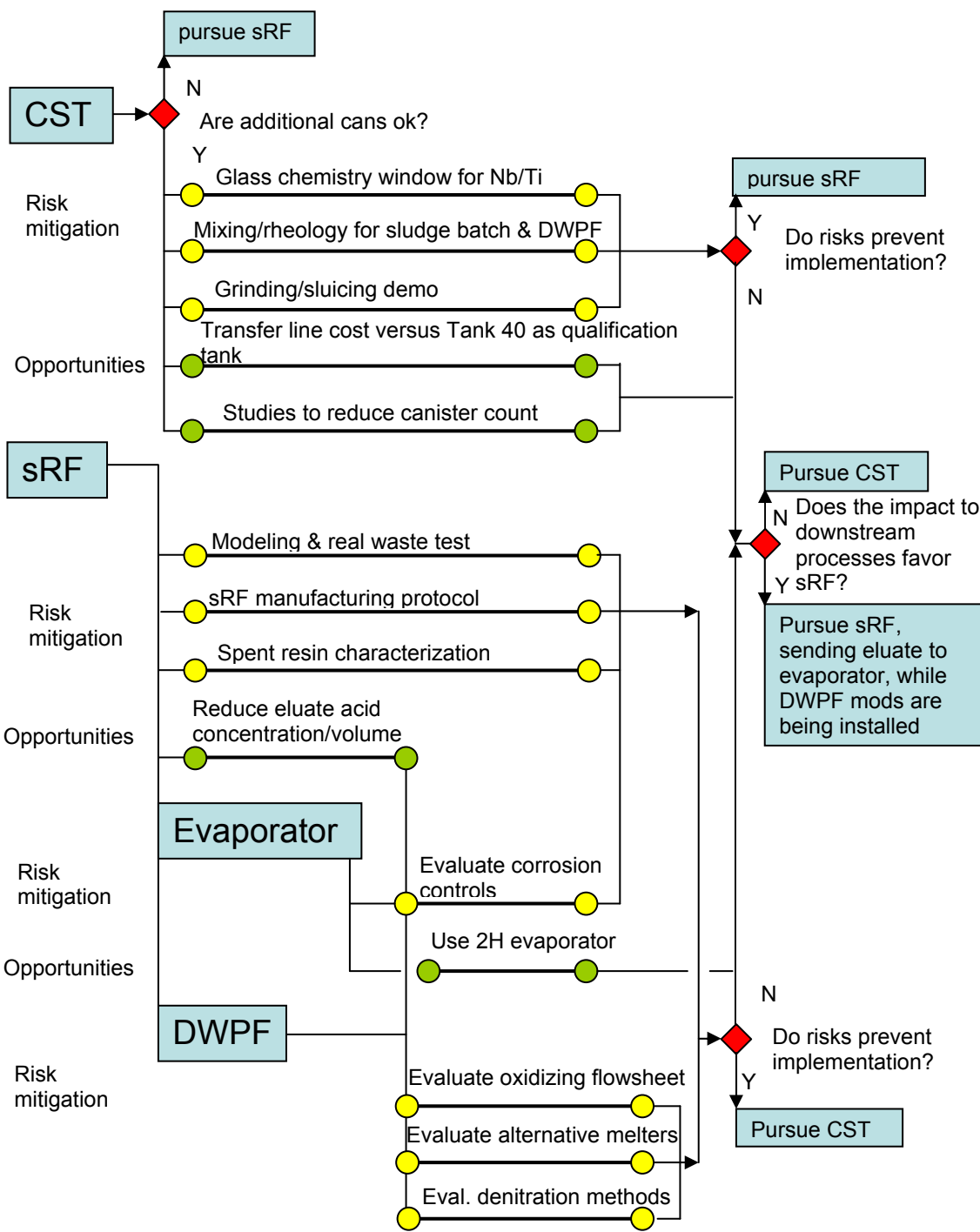

Fig. 4: IX Systems Engineering Evaluation Technology Maturation Logic

References

- 1 D. CHEW, M. MAHONEY, J. VITALI, LWO “Life-cycle Liquid Waste Disposition System Plan,” Revision 14, LWO-PIT-2007-00062, (2007).
- 2 G. WINSHIP, “PBS-SR-0014, Radioactive Liquid Tank Waste Stabilization and Disposition Risk Management Plan”, Revision 3, Y-RAR-G-00022, (2007).