

Development of AG-1 Section FI on Metal Media Filters - 9061

Duane J. Adamson, Savannah River National Laboratory
Savannah River Site, 786-5A Aiken, SC 29808

Charles Waggoner, Mississippi State University
205 Research Boulevard, Starkville, MS 39759

ABSTRACT

Development of a metal media standard (FI) for ASME AG-1 (Code on Nuclear Air and Gas Treatment) has been under way for almost ten years. This paper will provide a brief history of the development process of this section and a detailed overview of its current content/status. There have been at least two points when dramatic changes have been made in the scope of the document due to feedback from the full Committee on Nuclear Air and Gas Treatment (CONAGT). Development of the proposed section has required resolving several difficult issues associated with scope; namely, filtering efficiency, operating conditions (media velocity, pressure drop, etc.), qualification testing, and quality control/acceptance testing.

A proposed version of Section FI is currently undergoing final revisions prior to being submitted for balloting. The section covers metal media filters of filtering efficiencies ranging from medium (less than 99.97%) to high (99.97% and greater). Two different types of high efficiency filters are addressed; those units intended to be a direct replacement of Section FC fibrous glass HEPA filters and those that will be placed into newly designed systems capable of supporting greater static pressures and differential pressures across the filter elements. Direct replacements of FC HEPA filters in existing systems will be required to meet equivalent qualification and testing requirements to those contained in Section FC. A series of qualification and quality assurance test methods have been identified for the range of filtering efficiencies covered by this proposed standard.

Performance characteristics of sintered metal powder vs. sintered metal fiber media are dramatically different with respect to parameters like differential pressures and rigidity of the media. Wide latitude will be allowed for owner specification of performance criteria for filtration units that will be placed into newly designed systems. Such allowances will permit use of the most appropriate metal media for a system as specified by the owner with respect to material of manufacture, media velocity, system maximum static pressure, maximum differential pressure across the filter, and similar parameters.

INTRODUCTION

Metal media filters have existed for decades; predominantly in the form of sintered metal powder or metal wire mesh units. They have been employed in all sorts of operations and processes; however, there has not been an AG-1 section that addressed use on these types of filters in nuclear applications. A decade ago a working group was assembled by the CONAGT FC Subcommittee to begin the process of

developing a section of the standard for metal media filters. The initial intent was to have a single section that would cover all levels of filtering efficiency.

The working group labored for approximately three years to develop a standard that would facilitate use of metal media filters as a direct replacement of fibrous glass filters of HEPA efficiency. However, when the draft FI section was balloted, there were a sufficient number of negative observations that led the subcommittee to start over from first principles in redeveloping the section.

Rather than having the initiative lapse into inactivity, new members of the working group were enlisted to assist in the redevelopment process. One of the issues that had to be resolved involved the potential for metal media HEPA filters to serve as a direct replacement of Section FC HEPA filters. Numerous issues associated with this line of thought precipitated consideration of separating the initial draft into two sections; 1) one subsection addressing HEPA qualified efficiency units, and the other subsection addressing filters lower efficiency in a manner similar to fibrous glass filters (Section FC and FB).

The working group recognized the priority of developing a section of the standard for HEPA efficiency units, but also recognized the larger market potential for using metal media units upstream of conventional FC filters as protective prefilters. Such applications would not require that the metal media filters meet the 99.97% efficiency rating, and could be significantly lower as required by the application and still meet the requirements of the appropriate subsection. So a decision was made to limit applicability of Section FI to HEPA equivalent filters, and subsequently turn attention to the development of another section addressing lower efficiency units.

The 2006 Air Cleaning Conference resolved many of the issues associated with negative observations from the balloting of the initial FI draft. A status report on the progress of the working group was presented at the conference which detailed the approach being taken. A great deal of input was received from conference attendees emphasizing the need for a broader standard, one including efficiencies less than HEPA quality. The range of comments convinced working group members that a solution should be found to bring harmony to the wide variance of performance attributes of low and high efficiency metal media, whether made from sintered metal powder or fiber.

This two pronged approach has yielded the current draft of an FI section. The current draft includes requirements that address both high and low efficiency filters; requirements for units that can be utilized as direct replacements of Section FC HEPA filters, and requirements that can accommodate media manufactured from powdered metal or metal fiber. Additionally, the standard provides for qualification testing and for performance testing of filter elements and for units that are provided as complete assemblies of elements and housings. Each of these problematic issues have been addressed in the current draft version of the standard.

The approach taken has been to initially categorize units addressed under the section with respect to filtering efficiency. Two general categories exist, one for HEPA quality units and the other for lower efficiency units. The term unit is used here to represent either filter elements or functional units comprised of elements and housing.

The HEPA filter subsection is further subdivided with respect to design factors associated with how the filters will be deployed. This then divides HEPA filtering efficiency units into those that would be considered for direct replacement of Section FC filters in existing systems, and those that would be used in newly designed systems. The obvious difference in this division has to do with differential pressures (dPs), physical dimensions of the units, and media velocities. Clearly, metal media units can be packaged in different configurations from FC filters and are capable of withstanding much greater dPs. Subdividing the category with respect to application makes allowance for taking advantage of the strengths and

flexibility of metal media units in the design of new filtration systems. It also provides equal opportunity for use of either sintered metal powder or fiber media.

The second subsection of metal media filters addressed by this draft standard includes units with filtering efficiencies lower than the 99.97% level of HEPAs. This covers a wide range of potential applications for metal media filters.

The range of conditions that metal filters can withstand and the applications for which they may be used are diverse. Configurations and dimensional requirements can also be customized for a given application. Therefore, the standard has been drafted to allow for owner/designer specification of metal durability, dimensional specifications, media velocity, maximum and minimum differential pressure allowances, and filtering efficiency. It is to be understood that this flexibility of specification will be limited to filtration units used in newly designed systems or restricted to operating ranges of existing systems.

Language calling for design input on metal media filters includes the following:

A set of design/performance criteria shall be prepared by the Owner in sufficient operating detail to provide a complete basis for equipment design in accordance with this Code, including at minimum the temperature, pressure, and flow ranges of equipment operation. The chemical nature of solids, gases and liquids to which equipment internals and externals are to be exposed shall also be identified. Table FI-4110-1 gives an example of the parameters that can be specified in the design criteria for metal media and metal media HEPA filters. The list is illustrative only and can be reduced or increased as required by the Owner.

Examples of the parameters that can be specified by the owner are provided in Table I.

Table I: 4110-1, Example of Design Criteria for Metal Media Filters

Dimensions	Length, Width, Depth
Operating Conditions	Temperature and pressure range Initial and max dP Relative humidity range Media velocity (max, min) Volumetric flow (min, max)
Materials of Construction	Gasket material Filter media material Adhesive material Filter housing material
Mounting frame/housing	Allowable materials (corrosion resistance, durability) Structural requirements -deflection limits -impact loading -stress limits -equipment design verification
Access	Filter housing, filter element Location of filter
Filter media	Filtering efficiency Unique challenge conditions (NO _x , HCl, etc.)

As stated earlier, these user-defined criteria do not apply to metal media HEPA filters that will be used as a direct replacement for section FC fibrous glass filters.

The standard also addresses requirements of filter design by:

FI-4120 Metal Media Filters

Metal media filters are intended to be used in various nuclear air cleaning processes including applications for protecting workers, the public and the environment from hazardous and radioactive particles. Metal media filters shall be constructed to specific designs prepared by the Owner in sufficient operating detail to provide a complete basis for equipment designed in accordance with referenced standards in FI-2000 of this Code. The design of metal media filters can have a cylindrical or flat panel configuration.

The tensile strength and rigidity of metal media allow for the design of filters that are capable of withstanding much greater differential pressures than fibrous glass media. Flexibility is provided in the standard for the design of units to accommodate a wide range of air flows and media velocities. Section FI-4221 includes the opportunity to specify the range of differential pressures and media velocities and also specifies protocols for qualification and testing.

The resistance to airflow at the rated airflow of the clean filter shall be specified by Owner and shall be tested in accordance with FI-5111.

This break from tradition of having the standard restrict resistance to airflow by imposing a ceiling value for clean filters provides opportunity for numerous questions regarding filtering efficiency, effects on most penetrating particle size, and even the test methods for evaluating these parameters. The current draft of the standard takes into account that the conditions encountered by metal media filters may not be equivalent to those commonly used in testing fibrous glass filters.

Sufficient specificity of testing methods for ranges of filtering efficiencies is provided to establish a minimum set of test protocols, yet flexibility is provided to offer the owner/designer the ability to include test conditions necessary to ensure performance within the operational environment. The listing of test procedures for metal media filters in general are contained in subpart FI-5121:

FI-5121 Metal Media Filters

The resistance to air flow and test aerosol penetration shall be determined using a test method approved by the Owner. The following test standards can be used for the metal media filters:

- (a) ISO/TS 11155-1 for efficiencies between 10%-95% for KCl or equivalent particles with size of 0.3-10 microns. This testing standard is not designed for the extended media velocities possible with metal media filters. Filter efficiency testing of metal media filters at exaggerated differential pressures using KCl particles of the 0.3-10 micron size range can be accomplished in a manner equivalent to ISO/TS 11155-1 subject to approval by the Owner.
- (b) MIL-STD-282 for efficiencies between 95%- 99.99% for DOP or DOS particles with size of 0.3 microns.
- (c) IEST-RP-CC007.1 for efficiencies between 99.99%- 99.999% for various particles with sizes of 0.1-0.2 microns.

(d) SEMI F038-0699 for efficiencies between 99.999%- 99.999999% for particle sizes of 0.05, 0.07, and 0.1 microns.

(e) Other test methods based on the most penetrating particle size are also acceptable if approved by the Owner.

Modifications to the listed test methods may be required for metal media filters having high pressure drops, for example any unit operated and tested at media velocities sufficient to produce pressure drops in excess of 10 inches of w.c. The increase, if any, in filter pressure drop during the test shall be less than 5% of the initial pressure drop for the test to be accepted. Note that the ISO/TS 11155-1 test yields a filter efficiency curve as a function of particle size from 0.3 to 10 microns. The other tests yield filter efficiency at a single particle size.

The applicable testing standards for user defined performance criteria as defined above are not applicable for HEPA qualified metal media filters. Testing standards for HEPA filters are given in a separate section that has some commonality with those listed in subpart FI 5121. Specification of pressure drop for units of HEPA filtering efficiency is provided in one of two subparts, and testing of units intended as direct replacements of FC filters are tested by the same protocols as FC units.

FI-4222 Metal Media HEPA Filters

The resistance to airflow at the rated airflow of the clean filter to be used in applications originally designed for Section FC HEPA filters shall not exceed 3" water gauge (750 Pa), when tested in accordance with FI-5112. Rated airflow shall be as specified by Owner, and shall conform to Tables FI-4131 and FI-4132 when filters within design category FI-4130 are specified.

FI-5122 Metal Media HEPA Filters

The resistance to air flow and test aerosol penetration shall be determined using a test method approved by the Owner. The following test standards are approved for the metal media HEPA filters:

(a) MIL-STD-282 for efficiencies between 99.97% - 99.99% at particle size of 0.3 microns.

(b) IEST-RP-CC007.1 for efficiencies between 99.99% - 99.9999% for particle sizes of 0.1-0.2 microns.

Modifications to the listed test methods may be required for metal media filters having high pressure drops, for example any unit operated and tested at media velocities sufficient to produce pressure drops in excess of 10 inches of w.c. The increase, if any, in filter pressure drop during the test shall be less than 5% of the initial pressure drop for the test to be accepted.

The total test aerosol penetration through the filter shall be no greater than 0.03% of upstream concentration at rated airflow and at 20% of rated airflow.

Thus far the categories of filters covered under the draft FI standard have been included along with the introduction of owner-defined performance criteria. Test methods for filter elements or filter assemblies have been identified for the range of filtering efficiencies and operating conditions (differential pressures, etc.) covered by the standard. Before providing tables of configurations, nominal sizes, and performance

parameters for units covered under the standard, it is important to specify what the standard does not cover.

Numerous applications of metal media filters in nuclear environments are currently covered by existing standards. Most notably, bung vents for drums and vents for TRUPACs have standards that cover their fabrication and performance requirements. To include these units under this standard would require a mechanism to ensure harmony between standards or run the risk of conflicts as the individual standards are updated. For that reason, a list of “point of use” filters has been excluded from the standard with identification of the current standards covering them.

It must be acknowledged that currently metal media filters for applications larger than “point of use” units (such as drum or container bungs and instrument filters) are specialty units. This makes the process of providing general descriptive information (dimensions, flow rates, pressure drops, etc.) in the standard (because of the range and types of media used and the uniqueness of current applications) difficult at best and in all likelihood, misleading. Standardized sizes/configurations for larger flow rate units do not exist and metal media filters covered by this standard do not have “off the shelf” availability. The working group has expressed concern that including tables of representative descriptive data implying that standard sizes are available may jeopardize future use of the standard. Yet the group has also recognized that tables of nominal dimensions and performance information need to be included.

The following tables and additional descriptive language are provided for cylindrical filters and panel filters. Section FI-4121 provides tables of sizes and nominal performance data for various sizes of cylindrical metal media filter elements. It is important to emphasize the draft status of these tables. Tables II, III and IV provide data for a few of the many cylindrical metal media filters available from manufacturers. Many other sizes are available from the manufacturers. Data in these tables is provided as being representative of volumetric flow rates for a given length of filter element and differential pressure.

Table II: 4121-1, Ratings for Pleated Cylindrical Metal Fiber Media Filter Elements

1.3

Size ² (Diameter x Length)		Rated Flow		Rate Clean DP		
Inches	mm	acfm	M ³ /hr	psi	in w.g.	Pa
1.375 x 4	35 x 100	6	10	0.145	4	1000
1.75 x 5	45 x 125	10	17	0.145	4	1000
2.625 x 10	66 x 250	20	34	0.106	4	1000
2.625 x 20	66 x 500	40	68	0.117	3.2	790
2.625 x 30	66 x 750	60	102	0.124	3.4	850
2.625 x 40	66 x 1,000	70	120	0.132	3.6	910
3.375 x 10	86 x 250	40	68	0.110	3	750
3.375 x 20	86 x 500	60	102	0.117	3.2	810
3.375 x 30	86 x 750	100	170	0.128	3.5	880
3.375 x 40	86 x 1,000	110	187	0.143	3.9	980
4 x 10	100 x 250	50	85	0.106	2.9	730
4 x 20	100 x 500	70	120	0.113	3.1	775
4 x 30	100 x 750	100	170	0.124	3.4	845
4 x 40	100 x 1,000	120	204	0.138	3.8	945

¹ Penetration and flow resistance are to be specified by owner

² Other sizes are available

³ Filter elements only, not a finished filter housings assembly

Table III: 4121-2, Typical Sizes (Nominal) and Ratings of Metal Powder Media Cylindrical Filter Elements

Size (Diameter x Length)		Rated Flow		Efficiency (%) @ 1 μm	Rated Clean DP		
Inches	mm	acfm	M ³ /hr		psi	in w.g.	Pa
2 x 10	51 x 250	2.6	4.4	99.3	6.0	164	41,369
2 x 20	51 x 500	5.2	8.8	99.3	6.0	164	41,369
2 x 30	51 x 750	7.8	13.3	99.3	6.0	164	41,369
2 x 40	51 x 1000	10.5	17.8	99.3	6.0	164	41,369
2 x 50	51 x 1250	13	22.1	99.3	6.0	164	41,369
2.5 x 10	63.5 x 250	3.3	5.6	99.3	6.0	164	41,369
2.5 x 20	63.5 x 500	6.6	11.2	99.3	6.0	164	41,369
2.5 x 30	63.5 x 750	9.9	16.8	99.3	6.0	164	41,369
2.5 x 40	63.5 x 1000	13.2	22.4	99.3	6.0	164	41,369
2.5 x 50	63.5 x 1250	16.5	28.0	99.3	6.0	164	41,369
2 x 10	51 x 250	2.6	4.4	90	1.2	33	8,274
2 x 20	51 x 500	5.2	8.8	90	1.2	33	8,274
2 x 30	51 x 750	7.8	13.3	90	1.2	33	8,274
2 x 40	51 x 1000	10.5	17.8	90	1.2	33	8,274
2 x 50	51 x 1250	13	22.1	90	1.2	33	8,274
2.5 x 10	63.5 x 250	3.3	5.6	90	1.2	33	8,274
2.5 x 20	63.5 x 500	6.6	11.2	90	1.2	33	8,274
2.5 x 30	63.5 x 750	9.9	16.8	90	1.2	33	8,274
2.5 x 40	63.5 x 1000	13.2	22.4	90	1.2	33	8,274
2.5 x 50	63.5 x 1250	16.5	28.0	90	1.2	33	8,274
2 x 10	51 x 250	2.6	4.4	85	0.4	11	2,758
2 x 20	51 x 500	5.2	8.8	85	0.4	11	2,758
2 x 30	51 x 750	7.8	13.3	85	0.4	11	2,758
2 x 40	51 x 1000	10.5	17.8	85	0.4	11	2,758
2 x 50	51 x 1250	13	22.1	85	0.4	11	2,758
2.5 x 10	63.5 x 250	3.3	5.6	85	0.4	11	2,758
2.5 x 20	63.5 x 500	6.6	11.2	85	0.4	11	2,758
2.5 x 30	63.5 x 750	9.9	16.8	85	0.4	11	2,758
2.5 x 40	63.5 x 1000	13.2	22.4	85	0.4	11	2,758
2.5 x 50	63.5 x 1250	16.5	28.0	85	0.4	11	2,758

Footnotes:

1. Other sizes available
2. Metal media is 316L stainless steel
3. Atmospheric exit pressure
4. STP conditions
5. Air

6. These data representative of existing commercial product

Table IV: 4131-3. Typical Sizes (Nominal) and Ratings for In-Line High Pressure Metal Powder HEPA Filters

Size (Diameter x Length)		Media	Maximum flow rate at 9 LRV		Maximum Differential Pressure	
inch	mm		sm ³ /hr	acfm	inch water	Pa
0.75 x 3.31	19 x 84	Hastelloy C-22	0.48	.028	304	75,845
0.75 x 3.31	19 x 84	Nickel	3.00	1.77	304	75,845
1.50 x 3.31	38 x 84	316L SS	3.00	1.77	415	103,425
1.50 x 3.31	38 x 84	Hastelloy C-22	2.70	1.59	415	103,425
1.50 x 3.31	38 x 84	Nickel	7.20	4.24	415	103,425
0.75 x 5.00	19 x 127	316L SS	1.80	1.06	415	103,425
0.75 x 5.00	19 x 127	Hastelloy C-22	4.50	2.65	277	68,950
1.50 x 5.00	38 x 127	316L SS	18.00	10.59	360	89,635
1.50 x 5.00	38 x 127	Hastelloy C-22	6.00	3.53	471	117,215
1.50 x 5.00	38 x 127	Nickel	15.00	8.83	194	48,265
1.50 x 11.2	38 x 285	316L SS	18.00	10.59	471	117,215
1.50 x 11.2	38 x 285	Nickel	36.00	21.19	304	75,845
3.00 x 11.2	76 x 285	Nickel	90.00	52.97	304	75,845

Footnotes:

1. Other sizes available
2. Atmospheric exit pressure
3. STP conditions
4. Air
5. These data representative of existing commercial product
6. Flow could be higher and still provide HEPA grade efficiency

Manufacturers can supply the filter media in various materials such as 316L stainless steel, nickel, hastelloy C-22, etc. The metal media also comes in many forms such as sintered powdered, wire mesh, and metal fiber.

Figure 1 is a picture of one of the many sizes that a metal media cylindrical filter can be purchased. Also, various ends are available on the filter media for installing the filter into custom made housing. The ends on the elements in the picture are made for welding the elements into a housing.

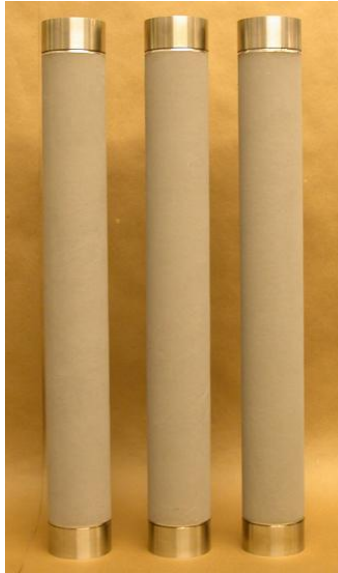

Figure 1: Sintered Metal Media Cylindrical Filter

Figure 2 is an example where the filter elements can be welded into a housing. The design of this filter housing is for a series of cylindrical filter elements install into a housing where the filters are cleaned in-situ.

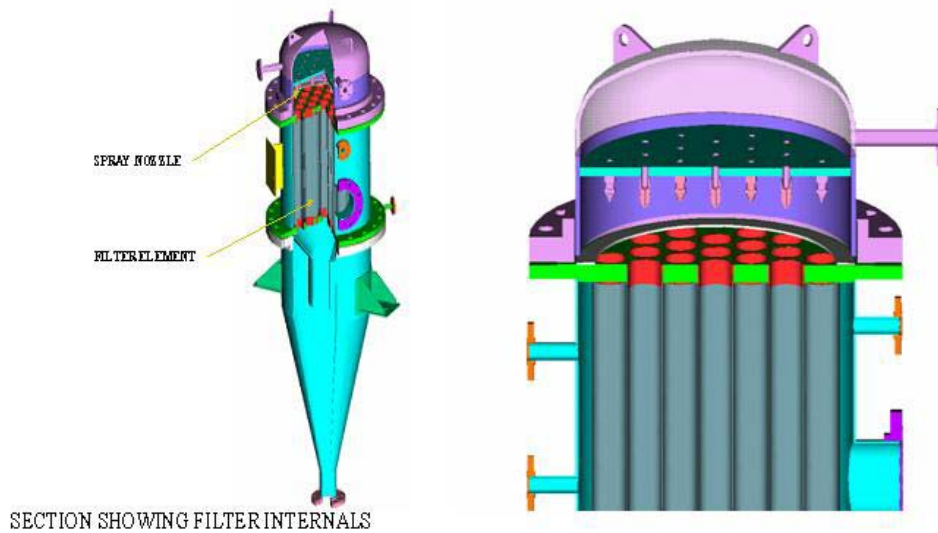

Figure 2: Metal Media Filter Element Installed into Custom Made Housing

FI-4130 Metal Media HEPA Filters

Metal media HEPA filters have strength and endurance capabilities different from Section FC fibrous glass HEPA filters. As such, Section FI filters may be utilized in broader applications than Section FC filters. Section FI of this standard addresses two categories of metal media HEPA filters: (1) units intended for direct replacement of Section FC filters in existing systems and (2) units placed into new systems designed and fabricated to meet owner defined acceptance criteria in addition to HEPA filtering efficiency. In this latter case, metal media HEPA filters shall be constructed to specific designs prepared by the Owner in sufficient operating detail to provide a complete basis for equipment designed in accordance with referenced standards in FI-2000 of this Code. The design of metal media HEPA filters can have a cylindrical or flat panel configuration.

- (a) The maximum housing pressure, maximum filter pressure drop, and maximum external housing leakage rate shall be as specified by the Owner.
- (b) If welding is employed in metal media HEPA filter element construction, the finished filter element shall be solution annealed in a reducing atmosphere.
- (c) Metal media HEPA filters shall be designed to meet qualification testing per FI-5100 and performance testing per FI-4200.
- (d) Metal media HEPA filters having cylindrical or other configurations with single or multiple filter elements are acceptable.
- (e) Construction shall conform to Section FI-6000.
- (f) Total mass of the metal media filters shall conform to load bearing capabilities of existing systems or new system design criteria.

FI-4131 Cylindrical Metal Media HEPA Filters

Cylindrical metal media HEPA filters can vary greatly in size and flow rating ranging from drum vent filters with a minimum flow of 35 ml/min to large facility ventilation filters with flows in excess of 2,000 cfm. Figures 3 illustrate examples of a cylindrical metal media HEPA filter designs.

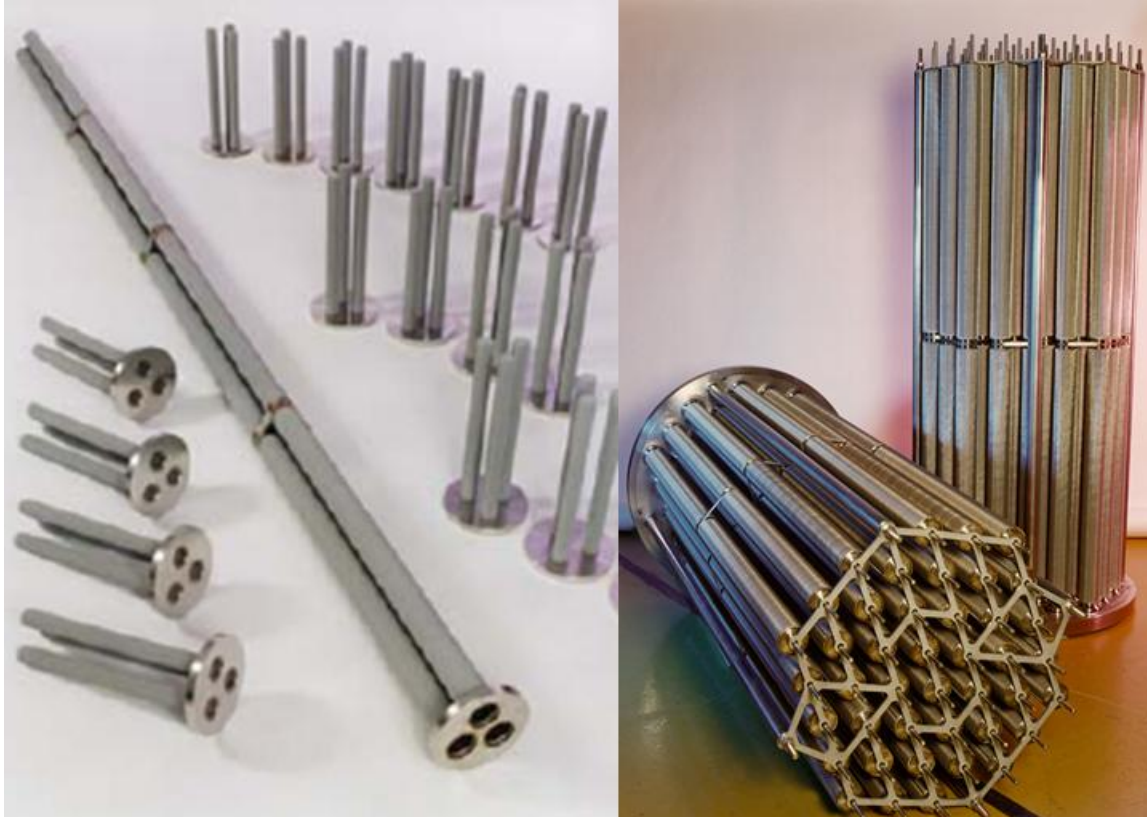

Figure 3: Picture of Metal Media HEPA Filters

Manufacturers can supply metal media HEPA filter elements in diameters and lengths as desired by the user. For the filter examples shown in Figure 3, the filter housing is also custom designed, similar to that shown in Figure 2.

A basic design for a panel metal media HEPA filter is shown in Figure 4 below. In this application a series of cylindrical filters are installed into a tube sheet, thus obtaining the required dP for a given air flow. The metal media filter design is for a direct replacement of a conventional 2x2x1 glass fiber HEPA filter into an existing housing.

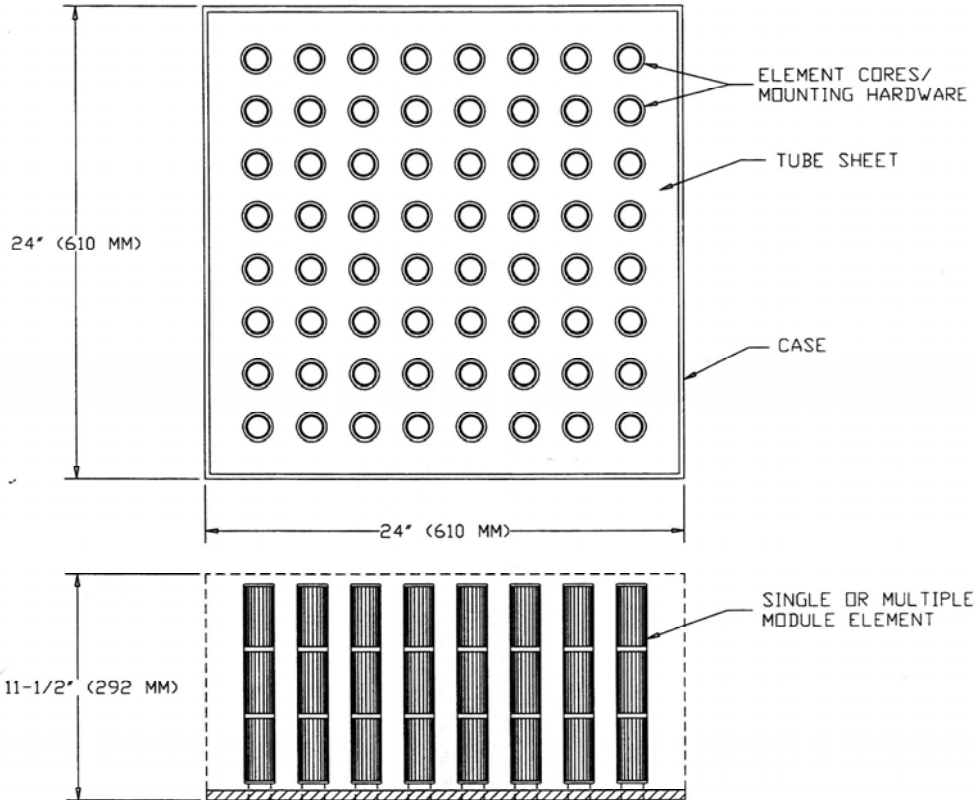

Figure 4: Metal Media HEPA Panel Filter

Dimensions, flow rating, and pressure drops for panel metal media HEPA filters have been standardized. While designs for panel filters capable of being directly substituted for Section FC fibrous glass media HEPA filters exist, metal media HEPA filters should still be considered specialty filters, since most applications are custom design for a given application. As such, panel metal media HEPA filters are subject to design specifications of the Owner. Data included in Table V are provided as representative of units for which designs exist or that have been used in an application. Other designs are also acceptable.

Table V: 4132 Typical Sizes (Nominal) and Ratings for Panel Metal Media HEPA Filters

		Clean
--	--	-------

Size ¹		Minimum Rated Air Flow		Maximum Resistance	
<u>Inches</u>	<u>mm</u>	<u>acfm</u>	<u>M³/hr</u>	<u>in-w.g.</u>	<u>Pa</u>
8 x 8 x 3 ¹ / ₁₆	203 x 203 x 78	25	42	3	750
8 x 8 x 5 ⁷ / ₈	203 x 203 x 149	50	85	3	750
12 x 12 x 5 ⁷ / ₈	305 x 305 x 149	125	212	3	750
24 x 24 x 5 ⁷ / ₈	610 x 610 x 149	500	850	3	750
24 x 24 x 11 ¹ / ₂	610 x 610 x 292	1000	1700	3	750
24 x 24 x 11 ¹ / ₂	610 x 610 x 292	1250	2125	3	750
24 x 24 x 11 ¹ / ₂	610 x 610 x 292	1500	2550	3	750
24 x 24 x 11 ¹ / ₂	610 x 610 x 292	2000	3400	3	750
12 x 12 x 11 ¹ / ₂	305 x 305 x 292	250	424	3	750

¹ Other sizes are available

(a) Where panel geometry is employed, the gasket shall be fixed to the metal filter housing with an adhesive in conformance with FI-3120 and FI-3130.

There are numerous other subparts of the current draft structure of Section FI that are not covered in detail in this paper. Unique issues of metal media filters include attachment of candle-type filter elements to a supporting plate, seams of cylindrical filter elements, sealing surfaces of filter elements and housings, and tests for air flow resistance and filter efficiency. While these issues are not trivial, there are reasonable solutions based on similar standards that have been referred to by the FI Working Group. The current draft also includes non-mandatory appendices such as one that provides guidance in the design of filter assemblies/housings to assist process design engineers in development of new systems.

While this paper does not provide complete coverage of the current draft of Section FI, its intention is to give the reader a sense of the areas of the standard that have been the most difficult to develop. There has also been an attempt to include those aspects of the current draft that have received the most comment and concern in past interactions between the FI Working Group, the Filtration Subcommittee, and the full CONAGT committee. It is hoped that presenting the issues covered in this paper will facilitate incorporation of input from conference attendees into a final draft that can be presented to the full CONAGT committee for balloting in the very near future.

CONCLUSION

Metal media filters have existed for decades and have been employed in all sorts of operations and processes. But there has not been a code developed for the Code on Nuclear Air and Gas Treatment (AG-1) that addressed use on these types of filters in nuclear applications.

A proposed code (Section FI) for AG-1 is currently undergoing final revisions prior to being submitted for balloting. The section covers metal media filters of filtering efficiencies ranging from medium (less than 99.97%) to high (99.97% and greater). Two different types of high efficiency filters are addressed; those units intended to be a direct replacement of Section FC fibrous glass HEPA filters and those that will be placed into newly designed systems capable of supporting greater static pressures and differential pressures across the filter elements.

Performance characteristics of sintered metal powder vs. sintered metal fiber media are dramatically different with respect to parameters like differential pressures and rigidity of the media. Wide latitude will be allowed in the code for owner specification of performance criteria for filtration units that will be placed into newly designed systems.

REFERENCE:

1. American Society of Mechanical Engineers, "Code on Nuclear Air and Gas Treatment", ASME, AG-1-2003, (2003)