

Automated Sampling and Sample Pneumatic Transport of High Level Tank Wastes  
at the Hanford Waste Treatment Plant

C. Phillips, J. E. Richardson,  
BNG America,

2345 Stevens Drive, Richland, WA, 99354, U.S.A.

## **ABSTRACT**

This paper describes the development work, and design and engineering tasks performed, to provide a fully automated sampling system for the Waste Treatment Plant (WTP) project at the Hanford Site in southeastern Washington State, USA. WTP is being built to enable the emptying and immobilization of highly active waste resulting from processing of irradiated nuclear fuel since the 1940s.

The Hanford Tank Wastes are separated into Highly Level Waste (HLW), and Low Active Waste (LAW) fractions, which are separately immobilized by vitrification into borosilicate glass. Liquid samples must be taken of the waste and Glass Forming Chemicals (GFCs) before vitrification, and analyzed to insure the glass products will comply with specifications established in the WTP contract. This paper describes the non-radioactive testing of the sampling of the HLW and LAW melter feed simulants that was performed ahead of final equipment design. These trials were essential to demonstrate the effectiveness and repeatability of the integrated sampling system to collect representative samples, free of cross-contamination.

Based on existing tried and proven equipment, the system design is tailored to meet the WTP project's specific needs. The design provides sampling capabilities from 47 separate sampling points and includes a pneumatic transport system to move the samples from the 3 separate facilities to the centralized analytical laboratory.

The physical and rheological compositions of the waste simulants provided additional challenges in terms of the sample delivery, homogenization, and sample capture equipment design requirements. The activity levels of the actual waste forms, specified as 486E9 Bq/liter (Cs-137), 1.92E9 Bq/liter (Co-60), and 9.67E9 Bq/liter (Eu-154), influenced the degree of automation provided, and justified the minimization of manual intervention needed to obtain and deliver samples from the process facilities to the analytical laboratories. Maintaining high integrity primary and secondary confinement, including during the cross-site transportation of the samples, is a key requirement that is achieved and assured at all times.

## **INTRODUCTION**

The U.S. Department of Energy (DOE) has responsibility for managing the safe storage, treatment, and disposal of high-level radioactive waste in underground storage tanks at the Hanford Site in southeastern Washington State, USA. There are 177 underground storage tanks containing over 204 million liters (54 million US gallons) of highly radioactive waste and 7.2E9 GBq (195 million

curies) of radioactivity.[1] This waste was generated primarily as a result of irradiated nuclear fuel processing for defense production activities from 1943 through 1989. Most of the 177 tanks are well beyond their design life and the removal and immobilization of the waste is a Hanford Site priority. In 1996, DOE initiated a project to treat and immobilize the waste and, subsequently, a team of contractors led by Bechtel National Inc.(BNI) was selected to design, build, and commission the Waste Treatment Plant (WTP) for this purpose.[2]

The WTP will separate the Hanford radioactive tank waste into High Level Waste (HLW) and Low Activity Waste (LAW) fractions and will separately immobilize these wastes by vitrification into borosilicate glasses.[3] The Immobilized High Level Waste (IHLW) and Immobilized Low Activity Waste (ILAW) glass products must comply with specifications established in the contract governing the vitrification work. IHLW must also comply with specifications in the Waste Acceptance Product Specifications (WAPS) developed by the DOE.[4]

Process control aspects of this compliance strategy are focused on measuring and controlling the feeds of waste and Glass Forming Chemicals (GFC's) for each process batch so that compliant IHLW or ILAW will be consistently produced. It is desired to avoid both the need for routine compliance sampling of the glass product and the possibility of the need to rework non-compliant glass. Therefore various samples, chemical analyses of samples, and measurements will be required to monitor and control the IHLW and ILAW vitrification processes, and it will be necessary to implement and demonstrate a range of qualification and production strategies for complying with the specifications. As part of this strategy, an automated sampling system is needed so that the radioactive samples can be taken and transported to the analytical laboratory safely and under full process control.

In June 2004, BNI awarded BNG America, British Nuclear Group's US subsidiary, the contract to design and supply such a system. The system design is based on that used successfully in several nuclear plants at the Sellafield nuclear processing site in northwest England. It comprises automated sample collection units ("Autosamplers") together with a pneumatic transport system to transfer the samples to the analytical laboratory. The Autosamplers are shielded, and located adjacent to the processing cells. Liquids are pumped by fluidic devices or mechanical pumps from the process vessels to the Autosamplers, where small sample volumes are transferred to sample bottles which in turn are placed in sample carriers and pneumatically transferred to the analytical laboratories. No manual intervention is necessary to deliver the process liquids to the autosamplers, or to obtain and transfer the samples through the pneumatic transport system.

The requirement was for a system to provide capabilities to obtain samples from each of the 3 separate processing facilities within the WTP; the Pretreatment Facility (PTF), the High Level Waste Vitrification Facility (HLW), and the Low Active Waste Vitrification Facility (LAW), and to transfer the samples pneumatically to the centralized Analytical Laboratory where the equipment delivers the samples to the stations to prepare for analysis. There are 47 separate sampling points in the process, and the 3 facilities and the Analytical Laboratories are separated by approximately 366 meters (1200 ft).

The scope of the work included the design and manufacture of 10 Autosamplers, 3 Laboratory Receipt stations, ancillary equipment to support the pneumatic transfer of samples, and the design and specification of the complete pneumatic transport system. Tasks also included the planning of operator training, technical support during installation, testing at the site, and start-up support.

As a part of the design & equipment selection and validation process, it was necessary to demonstrate the effectiveness and repeatability of the integrated sampling system, by demonstration of the collection of representative samples, using waste simulants as defined by the client. The physical and rheological compositions of the waste simulants provided an additional challenge in terms of the sample delivery, homogenization, and sample capture equipment design, mainly because of the non-newtonian nature of some of the sludge slurries to be sampled. In addition, equipment selection, handling, and shielding requirements were influenced by the activity of the actual waste forms, specified as  $4.86 \times 10^9$  Bq/liter (Cs-137),  $1.92 \times 10^9$  Bq/liter (Co-60), and  $9.67 \times 10^9$  Bq/liter (Eu-154).

This paper describes how the system is designed to provide an overall availability greater than 99.34% as mandated, by demonstrating availability through statistical analysis with substantiated assumptions. It further describes the non-radioactive testing performed on the LAW and HLW melter feed simulants, both with and without GFCs (Glass Forming Chemicals), and describes how the statistical difference between the mean values of the percent solids, measured from the vessel of origin, were compared to the sample obtained. The tests demonstrated excellent repeatability, in terms of volumetric accuracy and statistical difference. This provided a high level of confidence that the equipment incorporated into the design will ultimately provide the necessary degree of sampling accuracy.

## NOMENCLATURE

ABS	Acrylonitrile Butadiene Styrene
ALARA	As Low As Reasonably Achievable
BNG	BNG America British Nuclear Group's US based subsidiary
BNI	Bechtel National Inc
CAF	Controlled Arrival Facility
DOE	US Department of Energy
GFCs	Glass Forming Chemicals
HEPA	High Efficiency Particulate Arrester (air filter)
HLW	High Level Waste Vitrification Facility x
HLW	High Level Waste Vitrification Facility x
IHLW	Immobilized High Level Waste
ILAW	Immobilized Low Activity Waste
LAW	Low Activity Waste Vitrification Facility
MTBF	Mean Time Between Failures
MTTR	Mean Time to Repair
PLC	Programmable Logic Controller
PTF	Pretreatment Facility
PTS	Pneumatic Transfer System
RIO	Remote Input/Output
RFD	Reverse Flow Diverter (a type of fluidic pump)
Thorp	Thermal Oxide Reprocessing Plant (at Sellafield, UK)
WAPS	Waste Acceptance Product Specifications
WTP	Waste Treatment Plant

## SYSTEM OVERVIEW

The system injects samples through needles into polyethylene Sample Bottles sealed with rubber caps. These bottles are in turn enclosed in Sample Carriers which are then drawn by lowered air pressure through the transport piping from production facility to the laboratory. The system comprises three groups of equipment:

- **End Devices** including: Automated Sampling Machines (Autosamplers), Carrier Arrival Facilities (CAFs), and Bottle / Carrier Introduction and Receipt Stations (manual and automated).
- **Pneumatic Transport System Equipment** including: Exhausters, Diverters, HEPA Filters, Control Valves, Vacuum Lines, Carrier Transport Piping, and Carrier Tracking Switches.
- **Consumables** including: Carriers (may be multi-trip or one-way), Sample Bottles, Sampling Needles.

A system overview is shown in Figure 1. Five autosamplers are located within the Pretreatment Facility, three within the HLW Vitrification facility, and two within the LAW Vitrification Facility. Each machine can obtain samples from up to 6 separate sampling points. Samples are delivered to the autosampler either using power fluidic pumping devices [5], or conventional centrifugal pumps. Feed and return lines from the plant vessel being sampled enable continuous recirculation and thus help to ensure representative samples. When a sample is to be taken, a new Sample Bottle within a Carrier is automatically loaded into each Autosampler via a Carrier Introduction Station. The robotic arm within the Autosampler then removes the Sample Bottle from the carrier and moves it so that the sample needle pierces the rubber top and the sample is pumped into the bottle. The bottle is then removed automatically from the needle (the rubber cap self-sealing) and placed back in the Carrier for transport to the Laboratory. To allow for manually-taken low activity samples, a single Carrier Introduction Station is provided within the LAW Facility. This station allows for the manual introduction of Sample Carriers into the transfer system.

Within the Analytical Laboratory are two Hot Cell Receipt Stations, and a single Fume-Hood Receipt Station. The Hot Cell Receipt Stations are heavily shielded, and accept Carriers containing highly active samples. Carriers are automatically received, and the Sample Bottles automatically dispatched from these devices, operations that require no manual intervention. The Fume-Hood Receipt Station accepts low activity samples from the LAW Facility. Here, the low radioactivity levels allow for the manual handling of Sample Bottles and Carriers.

The Autosamplers and Receipt Stations are each fitted with a Carrier Arrival Facility (CAF). This key feature allows for the rapid acceleration, or deceleration, when a Carrier either departs, or arrives at the machine, and prevents any damage being caused to the Carriers.

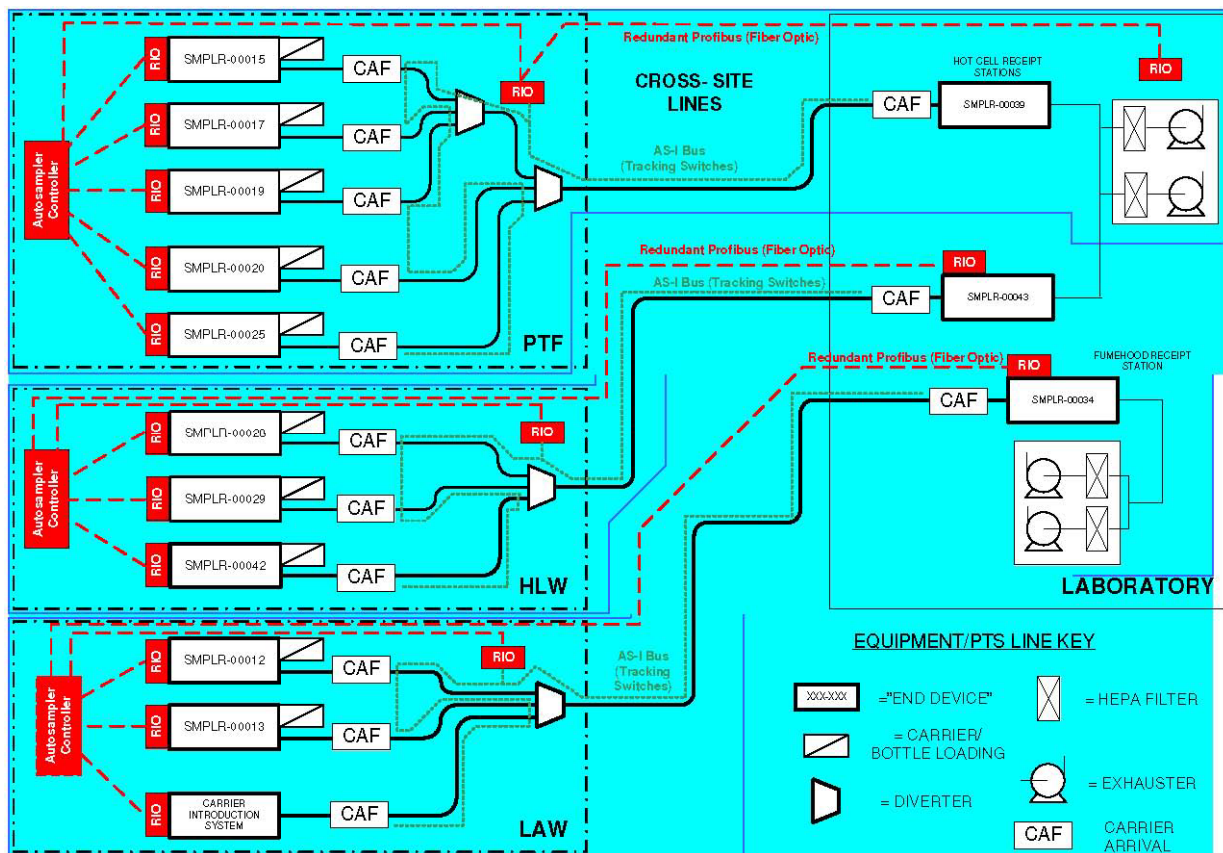

Fig. 1. Schematic of the autosampling system

The Pneumatic Transfer System comprises a network of piping and diverters, and connects the sampling devices on plant to the receipt facilities within the Analytical Laboratory. Tracking switches are strategically positioned on the transport piping, and are used to monitor the Carrier during its flight.

Exhausters, and vacuum piping within the Laboratory, provide the necessary motive force to draw the Carriers through the system at a speed of approximately 6 meter/sec (~20 ft/sec). A key design safety feature of each machine is the interlocked double door type seal, between the device and the Pneumatic Transport System. This insures that contamination cannot be drawn from the confines of the sampling devices and into the Pneumatic Transport system.

## EQUIPMENT FUNCTIONALITY

### Autosamplers

Autosamplers (Figure 2) are normally used for highly active applications, or/and where high frequency sampling is a requirement. They are designed for the life of the plant (up to 40 years). A fully automated interface with the pneumatic transfer system is provided, which totally eliminates any need for manual intervention during operation. The Autosamplers are modular in nature, and common components are employed to the fullest extent. For example, to limit the numbers of spare parts and increase operator familiarity, motors, sample docking units, and carrier arrival facilities

are identical for all automated devices within the sampling system. Items requiring maintenance are located in the inactive / clean areas; thus maintenance procedures are greatly simplified, and operator dose uptake is minimized. Liquid autosamplers are designed to obtain representative samples and will accept feeds from a number of devices, including fluidic pumps, e.g. Reverse Flow Diverters (RFD's) [5] and mechanical pumps.

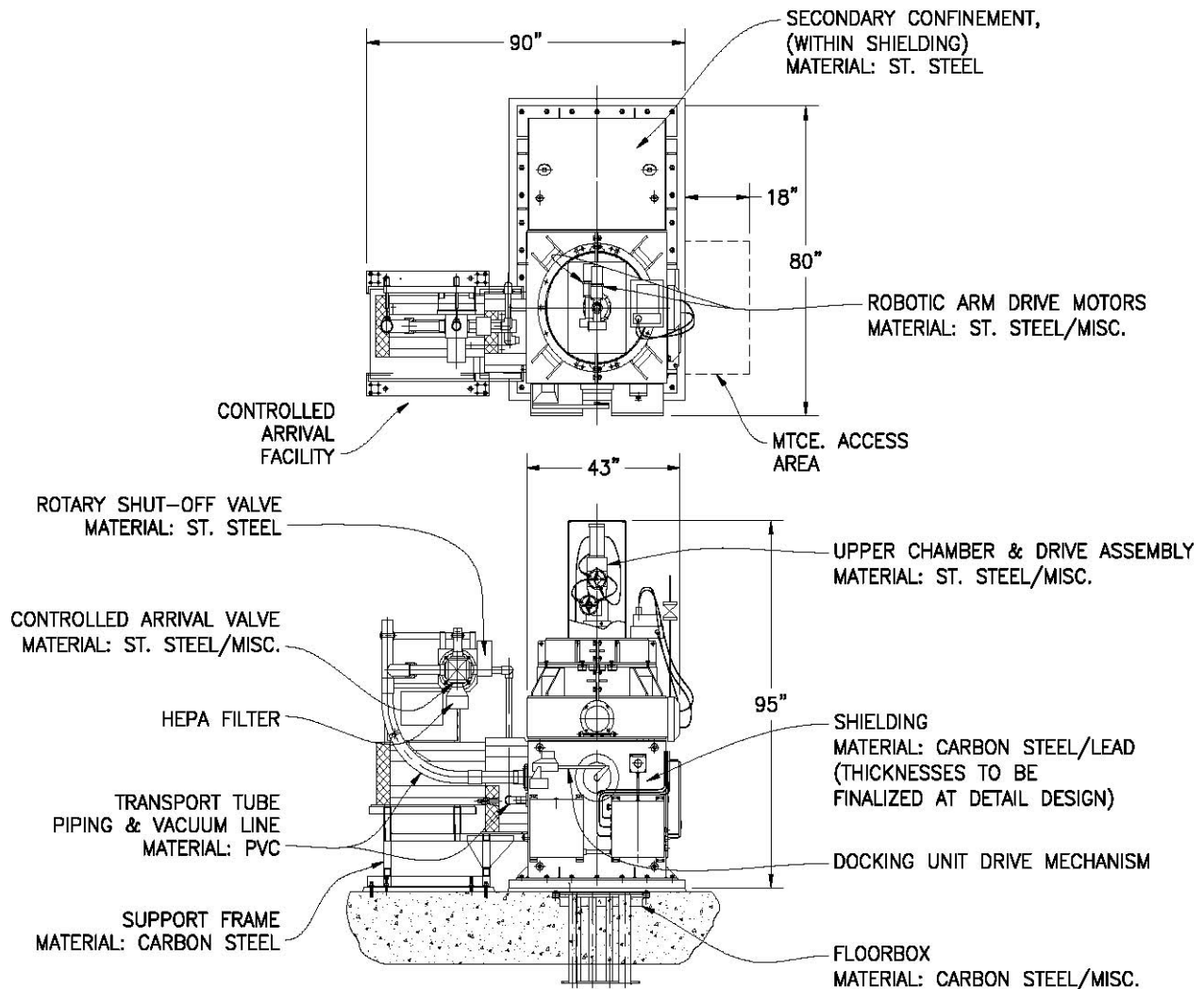

Fig. 2. Standard shielded autosampler (machines designed and fabricated to US customary units)

An integral part of the Autosampler, is the *Docking Unit*, which provides the interface between the pneumatic transfer system and the sampling chamber. The Docking Unit automatically receives a Carrier from the transfer piping, rotates the Carrier 90 degrees and raises it up to the docking port. The *Controlled Arrival Facility* (CAF), as incorporated in the design of the Autosamplers and Receipt Stations, is modular in nature, and standardized for use throughout the autosampling system. This tried and proven facility provides for the rapid deceleration of Carriers on arrival, and the rapid acceleration on departure. The *Seal Test Facility* is an essential design safety feature, and checks the docking port/carrier seal at specific stages of the automated sampling cycles. These steps

ensure that the Pneumatic Transfer System piping is isolated at all times from the autosampler's sampling chamber, thus preventing any movement of radioactivity into the pneumatic system.

The Autosampler *Chamber* is a containment vessel, with an access port in the base (referred to as the docking port). An air pressure depression is maintained within the chamber. The docking port is sealed at all times, by either the robotic arm (prior to arrival of a Carrier), or by the sample Carrier (on its arrival). A viewing window is provided in the chamber for occasional visual inspection of the internal conditions. Wash-down facilities are provided within the chamber, for cleaning the interior prior to performing maintenance. The radioactive sample pipes provide primary confinement, and are terminated at nozzles inside the chamber from where samples are automatically dispensed into sample bottles. Each nozzle is fitted with a renewable hypodermic needle. These can be removed and replaced by an automated cycle similar to the sampling cycle, an operation which requires no manual intervention.

The Autosampler *Upper Chamber and Drive* provides axial and radial actuation of the robotic arm and is fixed to the top of the chamber. It operates in a programmed sequence driven by stepping or servomotors. Arrival at the desired locations is monitored automatically to ensure correct location and performance. The moving parts of the drive are sealed to prevent any spread of radioactivity outside the chamber. A rotary drive monitor assembly provides an independent check of the robotic arm rotary movements. All motors are standardized across all machines.

Operation of the autosamplers is fully automatic, and controlled by local Programmable Logic Controllers (PLC). The autosampling sequence is automatically initiated by a signal from local instrumentation that senses the presence of a correctly oriented Carrier and Sample Bottle, delivered to the docking unit by the pneumatic transfer system. An incorrectly oriented Carrier is detected and will not initiate the autosampling process.

### **Carrier Introduction Station**

The Carrier Introduction Station allows manual introduction of Carriers and Sample Bottles into the pneumatic transfer system from locations where low radioactivity of the liquids being sampled render autosampling unnecessary. It includes a *Transfer Port* that is a standardized hinged-lid box with a latching lid. This device is equipped with a sensor for indication of lid actuation and a vacuum connection to facilitate Carrier transfer. The Transfer Port is a standardized design and is used elsewhere in the Autosampling System, including the Fume-hood Receipt Station within the Laboratory.

### **Hot Cell Receipt Station**

The Hot Cell Receipt station is essentially an Autosampler designed to work in reverse. It includes a Carrier Arrival Facility, a Docking Unit, a Seal Test Facility, Chamber and robotic arm, with features and functionality as previously described for the Autosampler. The Hot Cell Receipt Stations fully interface with the pneumatic transfer system and thus eliminate any need for manual intervention during delivery of the sample to the analytical laboratory hot cell.

### **Fume-Hood Receipt Station**

The Fume-Hood Receipt Station allows manual retrieval of Carriers from the pneumatic transfer system for low radioactivity samples that do not require shielding. This item incorporates a standard *Controlled Arrival Facility*, and *Transfer Port*.

## **Pneumatic Transfer System and Consumable Equipment**

The equipment that comprises the pneumatic transfer system includes the following items:

- Sample Bottles (single use).
- Sample Carriers (multi or single use)
- Vacuum pumps located within the Analytical Laboratory
- HEPA filters for exhausted air
- 2-way and multi-way Diverters to combine and split the transport piping
- Proximity (carrier tracking) switches to register the passage of Sample Carriers through the transport piping

The transport system for the Carriers is vacuum-induced so that the carriers are drawn through the transport piping to the Analytical Laboratory and the piping is maintained at a lower pressure than ambient air pressure.

*Pneumatic Transport System (PTS) Piping* provides the means of transporting the sample bottle carriers. The vacuum system pulls air through the transport piping, and exhausts it through HEPA filtration. Piping is commercially available stainless steel and plastic, uses long-radius bends and is joined using commercially available fittings. Some development work ensured that joins are consistently smooth and do not present an obstacle to passing Carriers. An important safety feature of the system is that primary and secondary confinement of radioactivity is provided by the Sample Bottles and Carriers respectively and does not rely on the transport piping. The *Vacuum Piping* delivers the vacuum to the pneumatic transport piping ahead of the carrier.

*Sample bottles* provide primary radioactivity confinement. Polyethylene bottles with self-sealing rubber caps are used. These bottles are tried and proven, with an excellent record of providing safe and reliable operation. *Carriers* provide secondary confinement, and are also a tried and proven design, constructed primarily of ABS plastic and stainless steel, with an excellent record of providing safe and reliable operation.

*Vacuum pumps* are standard commercially available items, used to provide the necessary vacuum to draw carriers through the pneumatic transfer system. *HEPA filters* are used to provide an effective barrier between the pneumatic transfer system and the working environment, the air being pulled through the interior of the pneumatic pipe is exhausted via the HEPA filters.

*Diverters* are mechanical devices built into the transport piping. They can be moved to direct a carrier to (or from) two or more possible destinations. Diverters are equipped with position sensors to the preset carrier path.

*Tracking Switches* are installed throughout the transfer system and are used to track the Carrier's progress through the system. They consist of reed switches, housed in weather-proofed boxes, and suitably shaped so that they can be fixed to the transport piping at predetermined positions and predetermined intervals. As the Carrier progresses through the transport piping, and past the tracking switch, the carrier's magnet activates the reed switch momentarily, but with sufficient mark-space ratio to be registered by a PLC. This system is well proven and reliable; all switches are identical, and are standard commercially available items.



## DESIGN METHODOLOGY

### Design Philosophy

British Nuclear Group has designed, supplied, installed, and operated several Autosampling systems for large, first-of-a-kind nuclear waste processing plants that have performed safely and reliably for decades. These have included the Thermal Oxide Reprocessing Plant (Thorp) [6] and Vitrification Plants [7] at Sellafield in the UK. These existing designs are modular, and comprise standard design features which are modified as necessary to meet individual requirements. The Autosampler units can be either wall or floor mounted to satisfy facility layout, and sampling points are oriented to satisfy hydraulic requirements or building layout constraints. Carrier and Introduction Stations, and Laboratory Receipt Stations can be manually operated, or fully automated to meet specific needs. For sampling liquids of lower radioactivity levels, a suite of standard designs exist for manual and semi-automated sampling machines that interface with the pneumatic transfer system. A typical wall-mounted, fully shielded Autosampling Unit, as used in Thorp, is shown in Figure 3.

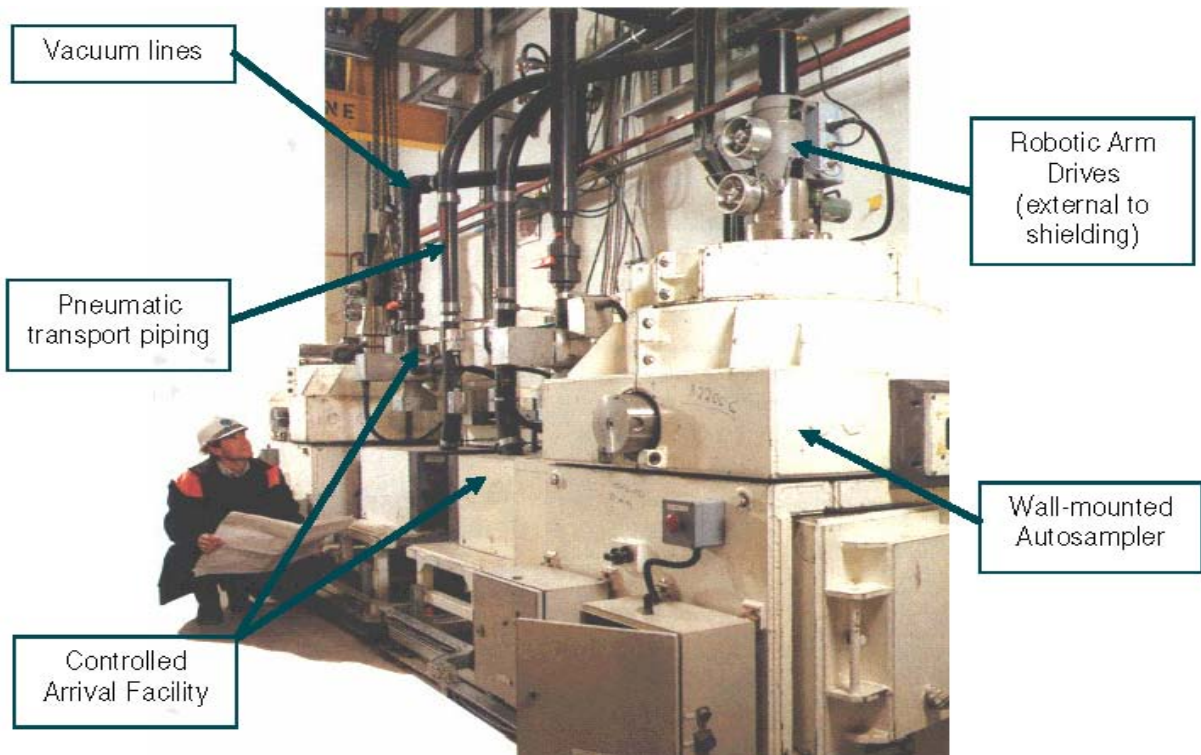

Fig. 3. Typical wall-mounted shielded autosampler

The design methodology for the WTP application entailed assessing these existing standard designs, and adapting them as necessary to meet the Project's requirements, while retaining the benefits of the tried and proven equipment. These benefits include:

- Embodiment of ALARA principles, by limiting the number of moving parts or items requiring maintenance inside secondary confinement, so as to reduce operator/maintainer radiation dose to the minimum
- Maintenance of a modular approach and adopting a standardization philosophy across all

components

- Minimization of component size, weight, complexity and cost
- Minimization of maintainability requirements by minimizing Mean Time Between Failures (MTBF), and Mean Time to Repair (MTTR).

### **Integrating Existing Autosampler Design Features to Satisfy WTP Requirements**

Examples of the specific requirements of the WTP project are as follows:

- Sample volume must be within +/-0.5 ml
- Statistical difference between the composition of the sample taken, and that of the source must be <1% and must be demonstrated
- High viscosity (30cP) and non-newtonian fluids (30 Pa yield stress) must be sampled
- Uni-directional flight required from Autosampler to laboratory, with one time use of each sample Carrier
- Carrier to be made of ABS plastic, with a weight constraint of 0.2 kg (0.44 lb) or less
- Maximum Autosampling machine weight to be 22,700 kg (50,000 lb)
- Maximum permissible equipment height to be from 2.13 -3 m (7-10 ft) (depending on location)
- “Bottle present” check required prior to taking sample
- Flushing of sample needle required after every sample
- Seal integrity between the Autosampler and the Carrier confinement, and their surroundings, to be tested, prior to each carrier transfer

The impact and resolution of these design criteria were assessed in detail so as to assure contractual and technical compliance with the contract requirements. A review was performed to identify those components and provisions in the British Nuclear Group design that were fundamentally important to the autosampler operation, and to assess how they could be preserved in the autosampler design for WTP while meeting the specific requirements of the contract. It was decided that there were three major components that should be retained in any autosampling system: the robotic arm, the docking port with its sealing mechanism and the docking unit. Together, these form the essence of a successful autosampling unit and enable the maximization of the benefits already realized with the proven design.

### **Precise Selectable Sample Volumes**

The WTP contract requirement was for precisely controlled sample volumes with an accuracy that exceeded the capability of (or requirement placed on) existing autosampler designs. A wide-ranging review of candidate commercially available sampling capture devices was conducted. A number were tested during a down-selection process.

This review showed that the existing design of upward orientation of the sample needle, and the use of pre-evacuated sample bottles, would not provide the sample volume control required by the contract. The conclusion was that the Isolok® mechanical grab sampling valve provided a high

level of confidence that the volumetric and representativity accuracy requirements would be satisfied. Incorporation of this sampler required a number of modifications to the standard Autosampler design. Most significant were the orientation of the sample discharge needle in a downward direction, the use of a non-evacuated sample bottle and the provision of a secondary needle for venting the bottle as the sample is pumped into it.

### **Maintenance of Equipment**

The inclusion of the Isolok® sampler introduced new maintenance challenges, and the following maintenance access options were considered:

1. Remote maintenance via manipulators
2. Remote maintenance via tongs
3. Hands-on maintenance via standard glovebox techniques

Option 3 was selected as the most cost effective solution. To keep extremity dose rates within acceptable limits, local shielding is provided around the radioactivity sources to shield the operator.

### **Positioning of Equipment**

For the existing design autosamplers, process pipes are routed beneath the device. This was not possible with the new WTP design, because of the need for downward discharge of the sample into the sample bottle. The process pipes are therefore routed in from the side and loop round and through the Isolok® sampler before exiting the autosampler. In addition, the robotic arm is re-orientated and positioned underneath the autosampler.

### **Needle Flushing**

The existing autosampling design includes a pneumatic blow-down facility for sampling points and operational experience has shown that this design successfully prevented blockages. The WTP autosamplers will, however, deal with much higher solids contents in the liquids being sampled and thus have a higher potential for blockage, particularly of the needle.

Hydraulic flushing of the needle was therefore introduced on the WTP autosampler design and this was facilitated by the downward orientation of the needle. Once the sample has been obtained, the sample needle is purged with a short spurt of air. This dispenses any residual liquid into the sample bottle. The sample bottle is then partially withdrawn so that the needle is positioned within a void space formed between the inner and outer rubber membranes in the sample bottle cap. Flush water is routed through this void space and discharges out via the secondary vent needle to the autosampler drain. A final blast of air drives out the residual flush water leaving the void space dry. This procedure also ensures no cross-contamination between one sample and the next.

### **Needle/Bottle Presence Detection**

The system includes a Bottle Presence Detection system that provides a check that both bottle and needle are present. An interlock prevents a sample being dispensed unless this check is positive.

### **Disposable Carriers**

A design requirement for WTP project was that sample Carriers are one-use only. A redesign of the Carrier was carried out so that the existing excellent confinement qualities and proven ruggedness are retained, while reducing the cost of the Carrier significantly, so as to make this disposability economically feasible.

### **Radiation Shielding Philosophy**

Embodying ALARA principles, the overall philosophy was to minimize the radiation source term by reducing liquid volumes within the system. For shielding three options were considered:

1. Placing all the shielding external to the confinement. This gave good maintenance access and represented a relatively simple design. However, the weight of the external shielding was prohibitive and there was a potential for operator dose uptake during maintenance.
2. Placing all shielding inside the confinement close to the radiation sources and eliminating the external shielding completely. This would be an optimum design, but space constraints prevented sufficient shielding being placed inside the confinement in this way.
3. A combination of internal and external shielding to, using higher density shielding materials where appropriate. This: a) minimized operator dose uptake during maintenance, b) satisfied dose-rate constraints outside the confinement, and c) resulted in an overall weight within acceptable limits.

Option 3 was the configuration selected.

### **Sample Transport**

Design and operational experience from the existing successful designs was used as the basis, with some modification work being necessary local to the Autosamplers to accommodate the methods stipulated for WTP sample Carrier loading.

## **REPRESENTATIVE SAMPLING TRIALS**

The autosampler system designed by BNG America for the WTP project has 10 autosampling units and each of these units can take samples from up to six vessels within the plant by the use of the Isolok® liquid sampling devices.

Representative Sampling Testing Requirements for WTP required that:

- Each HLW Vitrification and Pretreatment Facility sample must be  $15 \pm 0.75$  ml and that each LAW Vitrification sample must be  $35 \pm 1.75$  ml in volume
- The selected sampling delivery device must be tested to demonstrate the effectiveness and repeatability of the integrated sampling system to collect a representative sample using prescribed waste simulants
- An acceptance criteria established by the WTP contract required a  $\pm 1\%$  statistical difference between the mean values of the percent solids, measured from the test vessel and from the Isolok® sampler.

A test plan and component acceptance test procedure was developed as the execution plan for meeting these contract specification requirements.

A sampling device performance test loop rig was designed and built to replicate facility process conditions. These included; flow, pressure, system geometry (including pipe sizing), and physical characteristics. The test rig is shown in Figure 4 and comprised an agitated test liquid reservoir, a 50mm (2 inch) diameter recirculation loop, recirculation pump and the sampling device under test. Waste simulant specifications were used to manufacture the required volume of four separate test liquid simulants bounding all liquids that will be sampled in WTP. The selected sampling device was installed into the recirculation loop and operated through multiple sample extraction cycles.



Fig. 4. Sampling device performance test loop

For the statistical trials of solids weight percent measured from the sample device and from the tank being sampled, separate test programs were carried out with each of the four simulants. Each test program comprised:

1. 20 samples taken from the liquid reservoir at random locations
2. 20 samples taken at the liquid reservoir base
3. 20 samples taken from the sampling device under test

The weight% solids in each sample were analyzed independently. Results of (1) were compared to (2) to assess the degree of homogenization in the liquid reservoir. Results of (2) were compared to (3) to assess the performance of the sampling device.

A set of results for one of the four simulants is shown in the graph presented in Figure 5. The results are displayed in sample sequential number which advances with the time duration of the test. It can be seen that after an initial period, the measured solids content in samples randomly taken from the liquid reservoir, in samples taken from the reservoir base, and in those taken by the sampling device, all agreed closely, and well within contract  $\pm$  % requirement. The initial perturbation of the random tank samples is interesting and so far unexplained. It is under investigation.

Overall, the test results provided a high level of confidence that the system, when commissioned, will obtain representative samples on the plant.

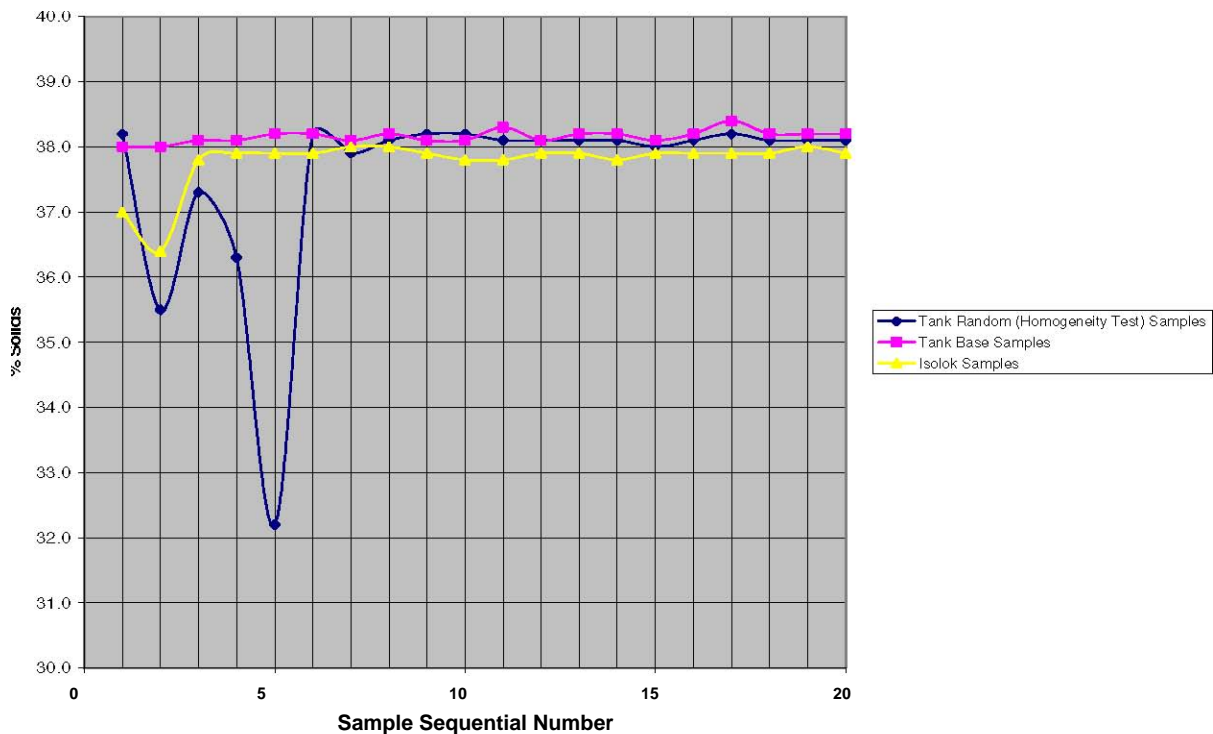

Fig. 5. Comparison of analyzed sample solids content

## RELIABILITY ASSESSMENT MODELING WORK

A reliability assessment of the Autosampling system was performed utilizing an Operational Research mathematical model which provides a visual and dynamic representation of the various processing stages in the Autosampling system and runs as a stochastic simulation tool, with random introductions of failures based on MTBF data, so as to predict downtimes and hence system availability that will be actually be experienced when the system is operating.

The model was developed using the WITNESS simulation software (Witness 2003 Simulation Software Full Version Release 2.00, Lanner Group USA). The model integrated the process flow diagrams (i.e. process and mechanical handling equipment, size, capacity and operational requirements), control and instrumentation requirements, operator interfaces, equipment reliability and maintenance requirements.

The design bases were derived from schematic diagrams, process diagrams, operational experience, reliability databases and appropriate engineering judgment. These were used to establish flow necessary to achieve the system availability targets.

### **Autosampling System Requirements**

The autosampling system requirements for WTP were as follows:

- The system will be capable of processing 150 samples per week
- The system shall be designed with an overall availability greater than 99.34%
- The system will operate for 24 hours per day, 7 days per week. The system cycle times associated with each sample taken, were derived based on the following:
- Operational experience from the British Nuclear Group autosampling systems currently in operation
- Sampling valve trials, and manufacturer's data on equipment performance
- Best estimates based on engineering judgment.

### **Equipment Reliability**

Data on reliability characteristics was gathered by two main methods; field experience and sample testing. The availabilities for each of the system components are shown in Table I.

Most of the data used was derived from field experience, drawing particularly on the Sellafield experience of autosampling system operation. Two other methods are used on occasions to provide useful data (i) 'expert judgment' where values for one device are estimated by comparison with other similar devices and (ii) Failure Modes and Effects Analysis (FMEA) where an estimation of the failure rates and modes of complex device are estimated from knowledge of failure rates of its components.

Table I. Autosampling System Component Availabilities

Equipment Item	Availability (%)
Isolok® actuator	99.9988%
Isolok® seals	99.9932%
Isolok® casing	99.9973%
3 way valve actuator	99.9990%
3 way process line wash valve	99.9954%
Sample needle	99.9875%
Sample nozzle	99.9420%
Docking unit	99.9991%
Docking unit magazine (solenoid)	99.9992%
Magazine air cylinder	99.9980%
Docking unit (HA Lab)	99.9938%
Robotic arm Seal plate	99.9865%
Robotic arm Outer arm	99.9891%

Table I. Autosampling System Component Availabilities

Robotic arm Base section	99.9880%
Robotic arm Bar code reader	99.9986%
Robotic arm Level instrument	99.9951%
Robotic arm Seal plate	99.9865%

A benefit of using plant specific data is that it reflects plant operations, maintenance and environments which are specific and demonstrable. Knowledge of the item for which data is sought, plus the information supplied by the database enables the assessor to find appropriate reliability data for that item. Much of the data on mechanical equipment is accurate, up-to-date and relevant having been obtained from current autosampling system operations.

The reliability data for each of the components identified was incorporated into the assessment model. The model calculates the time or the number of operations between breakdowns throughout the time period over which the simulation is run.

Availability is defined as the probability that at a given time a component will be in a working condition or available for use. The availability, expressed as a percentage, was calculated based on the reliability data and derived based on the component's Mean Time Between Failures (MTBF) divided by the sum of its MTBF and Mean Time To Repair (MTTR):

$$\text{Availability} = \frac{\text{MTBFF}}{\text{MTBF} + \text{MTTR}} \times 100 \quad (\text{Eq. 1})$$

By linking the individual processes together in the Autosampling model and taking into account the cycle times, operating rules and equipment reliability, both the overall system throughput and availability were calculated.

Based on a 10 year simulation of the Autosampling system model, the results indicated that approximately 154 samples can be processed within a week and an overall system availability of 99.55% will be achieved, illustrating that the system can achieve higher than the required throughput rate of 150 samples per week, and that a higher availability than the required target of 99.34% is achieved.

## CONCLUSIONS

The design and supply of the autosampling equipment for the WTP project at Hanford is an excellent example of a project where BNG America offered an existing tried and proven system, with adapted design features necessary to accommodate specific client requirements.

The scope of the contract includes the planning of operator training, technical support during installation, testing at the site, and start-up support. These are all areas where valuable experience has been gained over the past 35 years, in the design, supply, installation, commissioning, and operation of the company's own systems in the United Kingdom.

Meeting plant throughput requirements, and obtaining representative samples are both key issues. The ability to achieve an overall system availability of over the required 99.35% has been



WM'06 Conference, February 26–March 2, 2005, Tucson, AZ

demonstrated through dynamic modeling, using data from field experience and equipment testing. The ability to obtain representative samples is essential, particularly as the Immobilized High Level Waste (IHLW) and Immobilized Low Activity Waste (ILAW) glass products must comply with specifications established in the contract governing the vitrification work. IHLW must also comply with specifications in the Waste Acceptance Product Specifications (WAPS) developed by the DOE. Initial trials on the Isolok® sampling valve, itself with a tried and proven record, demonstrated that accurate and representative samples will be obtained when integrated with the autosampling system.

## REFERENCES

1. Regulatory Unit Position on the Achievement of Adequate Safety; Office of Safety Regulation of the RPP-WTP Contractor, Ref: RL/REG-2000-15 Rev 0, September 28, 2000.
2. WTP Contract No. DE-AC27-01RV14136, Contract Section C Statement of Work. Ref. RL/REG-2000-15, August 31 2000.
3. Top-Level Radiological, Nuclear, and Process Safety Standards and Principles for the RPP Waste Treatment Plant Contractor. Ref: DOE/RL-96-0006 Rev 3, February 2004
4. Waste Acceptance Product Specifications for Vitrified High Level Waste Forms (WAPS). U.S. Department of Energy, Office of Environmental Management, Washington, D.C. WAPS. Ref DOE/EM-0093. Rev. 2. December 1996.
5. Phillips, C., Richardson, J. E. and Fallows, P., “Maintenance-free Fluidic Transfer and Mixing Devices for Highly Radioactive Applications – Design, Development, Deployment and Operational Experience”, Waste Management 06 Conference, February 26 to March 2, 2006, Tucson, AZ, U.S.A.
6. Burrows, C., Phillips, C. and Milliken, A., “The Thermal Oxide Reprocessing Plant at Sellafield – Lessons Learned from 10 Years of Hot Operations and their Applicability to the DOE Environmental Management Program”, Waste Management 06 Conference, February 26 to March 2, 2006, Tucson, AZ, U.S.A.
7. Dobson, A. J. and Phillips, C., ”High Level Waste Processing in the UK – Hard Won Experience that can Benefit US Nuclear Clean-up Work”, Waste Management 06 Conference, February 26 to March 2, 2006, Tucson, AZ, U.S.A.