

AQUEOUS WASTE TREATMENT PLANT AT ALDERMASTON

D. Keene, P. Gilmour
RWE NUKEM

J. Fowler, M. Harrison
AWE

ABSTRACT

AWE plc is required to cease discharges of aqueous waste to the River Thames via the Pangbourne Pipeline (PPL) by 1 April 2005. A new Waste Treatment Plant (WTP) is therefore required.

Following a Best Practicable Environmental Options study (BPEO Study) the Preferred Method for the receipt, handling, treatment and disposal of the aqueous liquid waste has been identified as:

- Effluent Receipt, Collection and Buffer Storage.
- Coarse Filtration to remove large items of debris (e.g. leaves, bolts, etc.).
- Effluent Sampling.
- Effluent Pre-treatment (e.g. for pH or other process reasons).
- Closed Loop Hot Evaporation using Mechanical Vapour Recompression.
- Condensate Polishing by Reverse Osmosis Membrane Filtration.
- Permeate Collection, Sampling and Sentencing
- Discharge of Permeate as Trade Waste.
- Evaporator Concentrate Collection and Buffer Storage.
- Cementation of evaporator concentrate arising from the treatment process for disposal as Low Level Waste (LLW) to the UK national LLW repository at Drigg.

RWE NUKEM is working with AWE to implement this solution. The works involve process demonstration, design and build of a new treatment plant on the AWE site. The Plant will have a minimum design operational life of 25 years.

The performance target for the plant is one of the most stringent for any effluent treatment plant and will allow the treated effluent to be discharged as trade waste from the AWE site. Pilot plant trials have been undertaken that have demonstrated successful decontamination factors, and also confirmed measures for the control of foaming and scaling and conditioning by cementation of the concentrate suitable for disposal as LLW.

INTRODUCTION

A range of low-level aqueous waste reduction measures has been introduced at the AWE site in recent years. These include sampling at source, early decommissioning of parts of the existing waste collection system and introduction of alternative collection arrangements using Approved

Containers and tankers rather than pipeline transfers. This has resulted in a significant year on year reduction in the total volume of waste sent to the existing Liquid Effluent Treatment Plant (LETP) that currently discharges via the Pangbourne Pipeline. The ongoing implementation of an Environmental Management System to meet ISO 14001 and waste minimisation initiatives are expected to reduce the volume of arisings yet further. Current arisings of low level aqueous waste at AWE Aldermaston site are approximately 2500m³ per year (December 2003) from a starting point of over 8000m³ in December 2000. Effluent arisings will be reduced still further over the coming years as decommissioning and waste minimisation work progresses.

In parallel with these reductions in arisings, AWE has now implemented a project with RWE NUKEM to provide a new aqueous Waste Treatment Plant (WTP) at the AWE Aldermaston site to replace the existing LETP. The WTP Project is to design, supply, construct, install, test, commission and demonstrate over a 12 month period the performance of the plant. The project also includes all the safety case documentation requirements.

The WTP will ultimately allow AWE to cease discharges via the Pangbourne Pipeline from the Aldermaston Site and allow disposal of the treated effluent through the AWE trade waste drain system. Concentrates from the process will be treated through a cementation process and disposed of as LLW to Drigg.

The Plant is designed to be capable of treating effluent arisings of between 500 and 2500 m³ per year and is fully substantiated over this range.

WTP PLANT AND PROCESS DESCRIPTION

The WTP uses evaporation and Reverse Osmosis (RO) filtration to treat effluent arisings of up to 2500 m³ per year. The treatment process is a batch process, treating one or more tanks of received effluent in a short campaign and temporarily storing the treated effluent for a short period pending sample analysis results prior to discharge in accordance with the site authorisation issued by the Environment Agency under the Radioactive Substances Act 1993.

The performance target for the plant is one of the most stringent for any effluent treatment plant, with Decontamination Factors of many times greater than 1000 being required to meet the Trade Waste discharge criteria for gross alpha and beta activity. Tritium is not removed by the treatment process, but tritium levels are very low and well within authorised limits.

WTP Process Plant Construction

Significant consideration has been given to the construction and long-term reliable operation of the WTP process plant and equipment. Materials of construction for different sections of the plant have been selected to give reliable service for a 25-year design life in sometimes arduous conditions including high temperatures, high solids and high chloride concentrations. Nickel alloys are specified as well as plastics and more traditional stainless steels.

A detailed Availability, Reliability and Maintainability (ARM) study has been undertaken to demonstrate the WTP will meet the availability target and also to determine the maintenance regime utilising a Reliability Centred Maintenance (RCM) approach.

The plant is designed as a number of skid-mounted modules (skids) including:

- The two evaporator skids
- The RO equipment
- Several effluent pumping skids

This skid based approach has been chosen to maximize the amount of fabrication and testing that can be carried out at works and thereby minimize the amount of on-site installation, testing and commissioning. The benefits of this approach are better quality control, an improved implementation programme and reduced project risk.

A summary of the WTP effluent treatment process is illustrated in Fig. 1.

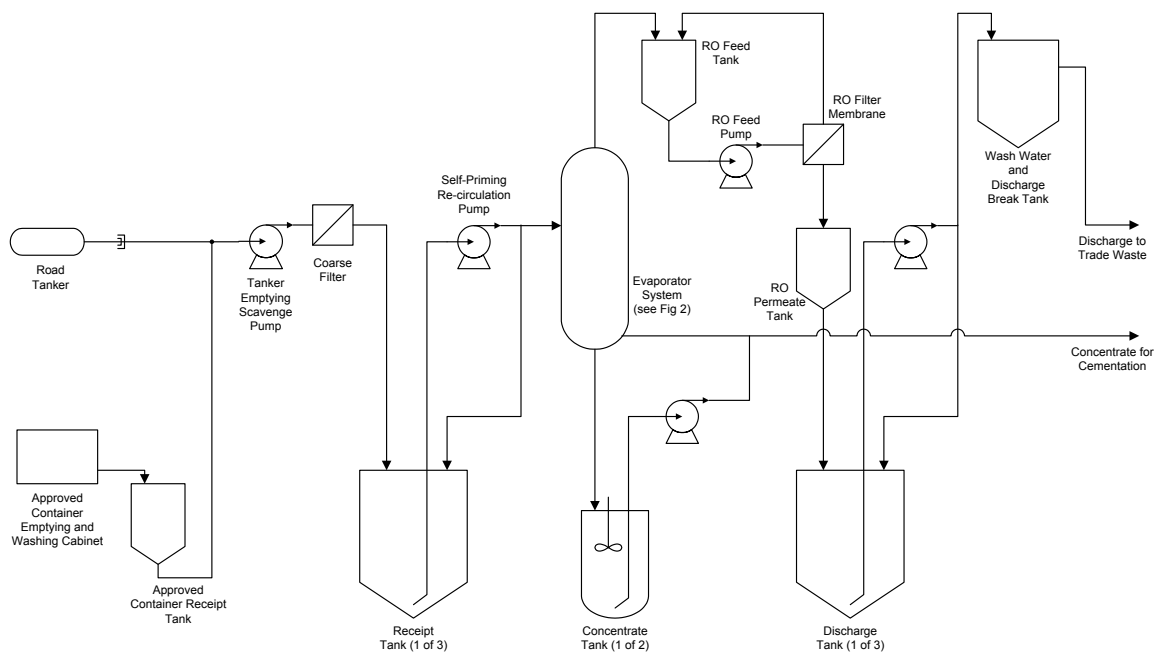

Fig 1. Overview of the WTP Process

Effluent Receipt

The process system accepts effluent from Tankers (typically 3-4 m³ batches) or Approved Containers (45-litre capacity double skinned carboys).

Tankers are parked adjacent to the WTP building and a connection is made from the tanker to the plant. The Tanker Emptying System is located on a dedicated skid within a bunded area adjacent to the tanker parking area inside the building.

Tanker emptying is initiated from the central control room and the contents pumped from the tanker using a centrifugal scavenge pump via coarse cartridge filters and into the designated Receipt Tank.

Approved Containers are off loaded from the delivery truck and stored at the WTP facility. The Approved Container Emptying and Washing Cabinet contains the equipment for handling, emptying and washing approved containers.

Approved Containers are manually entered through a vertical access door into the Cabinet. A dip pipe is then used to pump out as much of the contents to the Approved Container Receipt Tank.

Periodically the contents of the Approved Container Receipt Tank are transferred to the Receipt Tanks by using the Tanker emptying scavenge pump.

Raw Effluent Buffer Storage

Three Receipt Tanks are provided to allow for process segregation, holding and monitoring and the de-coupling of effluent receipt from the downstream processes. Each Receipt Tank is of polypropylene lined GRP construction and has an operating volume of 35 m³. The tanks are located within a bunded tank room.

Each tank is served by its own self-priming centrifugal pump mounted above each tank. The pump is used to mix the tank contents by re-circulation. Samples can be taken from the recirculation loop for analysis. If required, the tank can be dosed with an anti-foaming agent, acid or alkali via a connection into the recirculation loop of the tanks.

When the contents of the tank are ready for processing, the transfer to the evaporator is via a bleed from the tank recirculation loop.

Evaporation

There are two evaporator systems, each evaporator is capable of treating 0.5 m³/h. During the first few years of operation, both evaporators will be required to operate in parallel. In the subsequent 20 years, only one of the two evaporators will be required because of the lower effluent arisings.

A simplified arrangement of the evaporator system is shown in Fig. 2.

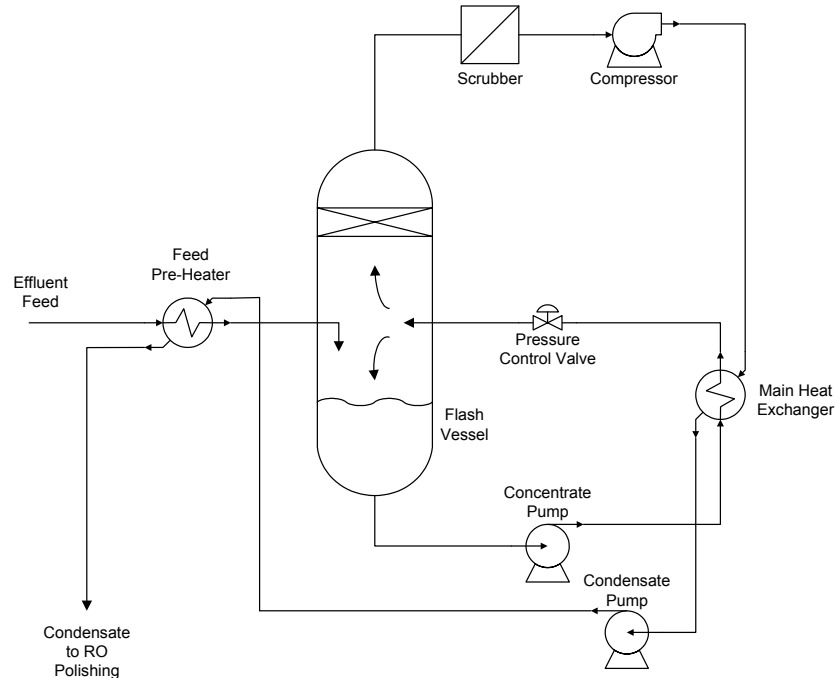

Fig 2. Evaporator MVR Circuit

The feed from the Receipt Tank enters the Flash Vessel via a Regenerative Heater that heats the effluent to approximately 95 °C before entering the Flash Vessel. The Regenerative Heater is a shell and tube type heat exchanger.

The chosen evaporation technique utilises Mechanical Vapour Recompression (MVR). The vapour from the Flash Vessel is drawn off using a vapour compressor that raises the temperature of the vapour to 114°C and provides the energy for the process to become self-sustaining, without the need for further heating. Variable speed compressors are used and their control is linked to maintaining a constant level of concentrate in the Flash Vessel. The compressed vapour is then injected into the Main Heat Exchanger.

Concentrate is drawn from the Flash Vessel and pumped through the Main Heat Exchanger by a Concentrate Pump. The Main Heat Exchanger is a shell and tube type heat exchanger. In the Main Heat Exchanger, the compressed vapour in the condensate loop heats the concentrate.

A pressure control valve prevents boiling of the concentrate within the Main Heat Exchanger. On release of the pressure after the valve, the concentrate forms a two-phase mixture that separates in the Flash Vessel into a vapour phase and concentrated liquid phase.

The flash vessel is fitted with a disentrainment section and a vapour scrubber to minimise the carryover and hence improve the Decontamination Factor (DF) of the plant. Dis-entrained and scrubbed liquid is returned to the Flash Vessel.

The condensed vapour from the Main Heat Exchanger is collected within the Sump Vessel and then pumped to the RO plant using the Condensate Pumps, via the Regenerative Heater (to pre-heat the new feed to the Flash Vessel) and a Sub-cooler.

Any gases from the Sump Vessel pass to a Vent Condenser where non-condensable components are vented to the active ventilation system.

Start-up of the evaporator involves a warm-up sequence during which a batch of effluent is recirculated within the evaporator and live steam is injected into the Main Heat Exchanger. Once the evaporator is up to temperature, the MVR takes over as the source of heat and the steam is shut off.

Evaporator Condensate Polishing

The evaporator condensate is transferred direct to the RO Feed Tank. There are two RO units each of capacity 0.5 m³/hr to treat the condensate from the two evaporators.

In each RO unit, evaporator condensate is pumped by the RO feed pump from the RO Feed Tank into the membrane filter elements. The RO membrane elements effectively separate the pressurised condensate into two streams:

- Permeate that passes through the membrane and is essentially clean water containing a very small proportion of dissolved solids, and
- Retentate that contains the remaining dissolved solids contained in the feed condensate.

The retentate is then returned to the RO feed tank where it mixes with incoming evaporator condensate.

Periodically, the retentate in the RO Feed Tank is transferred back into the designated Receipt Tank for re-treatment via the evaporator.

The permeate is collected in the Permeate Tank. From here the permeate is either processed by further polishing via an Ion Exchange Column or transferred directly to the designated Discharge Tank. The Ion Exchange polishing will normally only be used in the event of the need to re-treat a batch of effluent in a Discharge Tank.

Effluent Discharge Tanks and Wash Water / Discharge Break Tank

The RO permeate is received into one of three Discharge Tanks. Each discharge tank is of polypropylene lined GRP construction and has an operating volume of 35 m³. These tanks are located within the same bunded tank room as the receipt tanks.

When a tank is full, the contents are recirculated to allow a representative sample to be taken from the recirculation loop.

Once analysis has shown that the tank contents are within the acceptance criteria, the tank is ready for discharge to the Wash Water and Discharge Break Tank. This Break Tank stores a volume of treated effluent for use as wash water within the WTP and provides an atmospheric break at a high point within the building to prevent the accidental emptying of a discharge tank through the establishment of a siphon into the Trade Waste system.

As the treated effluent leaves the building under gravity, the flow and pH are measured and an automatic sampler takes a final representative sample.

If analysis shows the contents of a discharge tank are not acceptable for discharge the contents can be returned to either the evaporator and/or the RO units for reprocessing.

Concentrate System

At the end of each batch campaign, the concentrate from the evaporator is transferred from the Flash Vessel by a Concentrate Transfer Pump on the evaporator skid to one of two Concentrate Tanks.

The Concentrate Tanks are fitted with an impeller agitator to provide continuous mixing of the concentrate. The contents of the Concentrate Tanks can also be recirculated or transferred using a peristaltic pump.

There is also the ability to allow the settling of the contents of the Concentrate Tanks so that the supernate can be decanted off from the vessel and transferred back into the Evaporator for further concentration

In order to minimise the amount of concentrated material requiring storage, the stored concentrate is returned periodically to the evaporator for further concentration at the end of each campaign. Therefore, the solids concentration of the stored concentrate is gradually increased over a period of several months. When the concentration reaches 20 to 30 wt.%, the concentrate is transferred to the second Concentrate Tank to await cementation.

Cementation

Provision is made for the operation of a cementation plant within the WTP facility. The necessary services for operation of the plant are provided within the building infrastructure.

The cementation plant is operated in the Cementation Area, which is a radiologically designated area served by an active ventilation extract.

The concentrate is encapsulated into either 205 or 240 litre drums fitted with a "lost-paddle" mixer. The WTP is able to accommodate all the full and empty drums (up to 80) that will be consumed and generated during the annual cementation campaign.

A drum is positioned below the mixing head within a drip tray on a lift table. The drum is then raised to seal the drum against the bottom plate of the mixing head automatically coupling the captive paddle mixer blade within the drum to the mixer drive.

The concentrate is added to the drum, with the quantity being controlled by level within the drum. The paddle is then started and cement powder from the Cement Hopper Discharge unit is added to the waste within the drum. An integral extract unit controls the release of cement dust during its addition to the waste drum.

Once mixed with cement, drums are removed, lidded, monitored and stored overnight to cure. The following day the product is checked before being transferred and loaded into a half height ISO (HHISO) container for transport and disposal as LLW to BNFL, Drigg.

Process Control and Operation

Two PC based control stations are installed in a control room that is outside of the radiological designated areas. These control stations provide supervisory and control functions for the process plant and building heating and ventilation system. Each of the control stations has the same access capability to the controlled items.

Process control is designed to be autonomous as far as possible. This enables minimal manning levels to be achieved.

Control is provided by a full featured, industry standard Supervisory Control and Data Acquisition (SCADA) system. The primary interface to the operator is a graphical display (mimic) that shows a representation of the plant or equipment in P&ID form.

The control system can automatically shutdown the plant in a safe manner on detection of abnormal conditions. Safety functions are able to shut down plant items independently of the control system when tripped. All safety related functions are hardwired and operate independently to the software control system.

The following operations will take place during normal site working hours i.e. days only operation:

- Tanker receipt and emptying.
- Approved Container receipt and emptying /washing, typically processed in batches of 10 to 20.
- Raw effluent sampling).
- Start-up of the treatment process (approx 50 campaigns per year i.e. one campaign per week).
- Treated effluent sampling.
- Treated effluent discharge.
- Concentrate cementation (80 drums per year in one two-week campaign).

Tanker receipt and emptying operations would take place during the normal working day only. Similarly, Approved Container receipt will also take place during the normal working day. Approved Container emptying operations would take place during the normal working day once a suitable batch had been collected.

Once a Receipt Tank is full and isolated it will be sampled and analysed. The analysis will typically take 1 to 2 days to process. Once the results are available, and assuming that they are acceptable, then the tank is ready for processing. Start-up of the treatment process, involving the warm up sequence of the evaporator, would take place during the normal working day, typically starting in the morning.

Once the plant has started processing, it is designed to process effluent without any operator intervention. The control system monitors and controls the batch and then shuts down automatically on completion of the batch. Once initiated, the process will be able to be left processing unmanned overnight to complete a batch of one or more Receipt Tanks. On completion of the batch, the process plant will shutdown automatically, with the evaporator going through a controlled cool down sequence. This can occur with or without the operators present.

Discharge of the treated effluent from the Discharge Tanks will be a manned operation and will take place during the normal working day.

Staffing requirements for the building are limited. It is expected that the day-to-day process of receiving, treating and discharging effluent will only require two to three operating staff in the building, including a health physics surveyor.

WTP Process Plant Layout

The arrangement of the WTP is illustrated in Figs. 3 and 4.

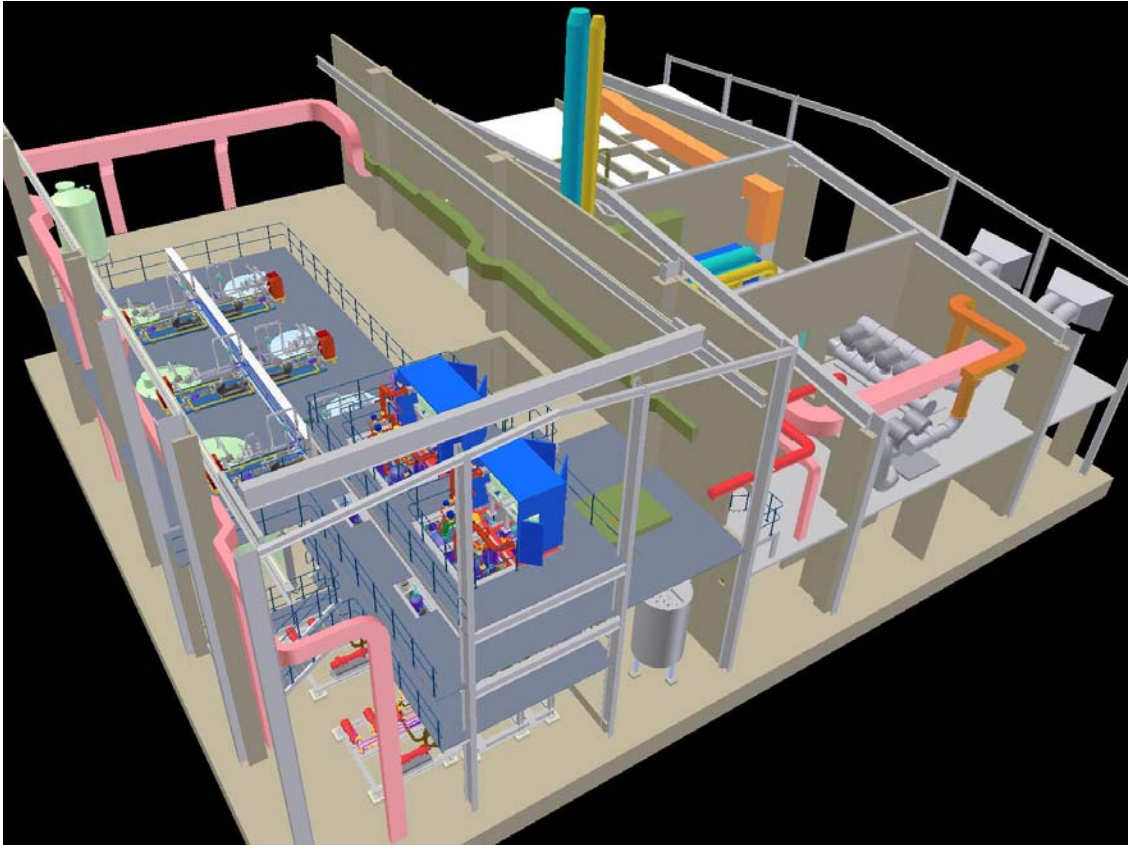

Fig. 3 3-D model picture of the WTP

The WTP building generally comprises several areas arranged over two floors:

- The main process area housing the majority of the process plant and equipment.
- The cementation area for location of the cementation plant and equipment.
- The receipt and dispatch area including the tanker off-loading and approved container emptying areas.
- The accommodation areas on the ground and first floors including offices, control room and mess facilities.
- The change room.
- The fan and filter rooms housing the building ventilation equipment and the adjacent chiller room housing the process cooling water chillers as well as the HVAC chillers.
- The service rooms on the ground floor housing electrical and mechanical services as well as a chemical store.

The main Receipt and Discharge Tanks, six tanks in total, are located on the ground floor of the building. The pumps and equipment for emptying and transferring the contents of these tanks are located above the tanks at the first floor level. This arrangement allows all the process pipework to be drained back to the tanks. The tanks are contained within a bunded area. A grillage floor is provided over the tanks to allow operator access to the tank pumps and to the top of the tanks.

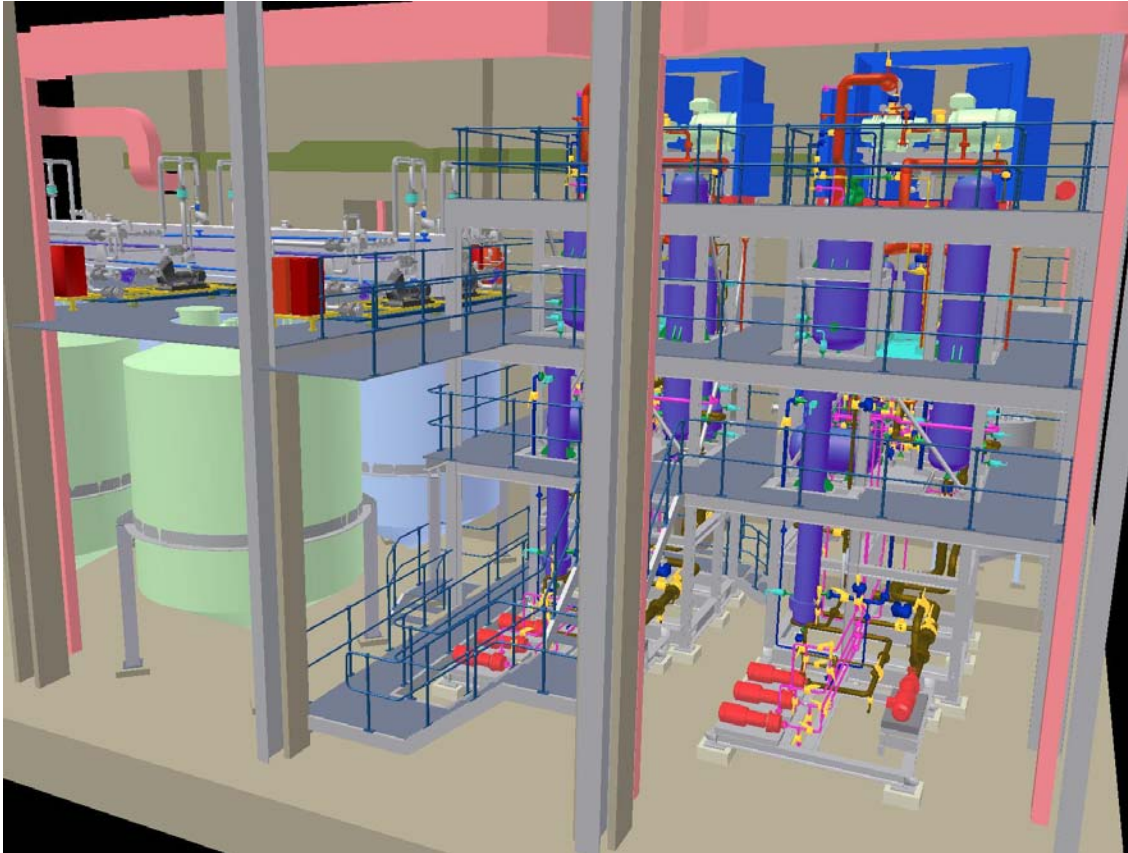

Fig. 4 3-D model picture of the WTP showing the two evaporator modules

The evaporators are housed in one corner of the building, adjacent to the tanks. The evaporator modules sit at ground floor level and are over 7m tall. Intermediate access platforms are provided for maintenance of equipment on the modules.

Adjacent to the evaporators is another bunded area housing the concentrate storage tanks. Again, the pumps and equipment for emptying and transferring the contents of these tanks are located above the tanks at the first floor level.

The RO polishing plant and the final Wash Water and Discharge Break Tank are located at first floor level adjacent to the receipt and discharge tanks.

WTP Building and Services

The Waste Treatment Plant (WTP) is to be located on the AWE Aldermaston site. It will be housed in a new building on a brown field site and is equipped with the following services:

- Ventilation serving the general accommodation area, the radiologically designated areas and the process equipment.
- A 5-tonne crane for plant installation and maintenance
- Steam for evaporator start-up and building heating
- Compressed air, electricity and water and drainage (separated into Foul, Surface Water and Trade Waste)

The building is a simple, non-seismic, steel framed and clad structure. It is 34m by 28m in plan. The building roof profile is at 2 storeys (9m) with part rising to a height of 3 storeys (13m) to facilitate the traverse of the building crane and the full first floor process area.

WTP IMPLEMENTATION

Programme

The implementation stage of the project began in January 2003 with the preparation of the Plant Design and the Pre-Construction Safety Report (PCSR). These were completed in July 2003. In addition, groundworks in support of the plant construction commenced ahead of programme in August 2003.

In parallel with this work, pilot plant trials have been undertaken that have demonstrated successful decontamination factors, control of foaming and scaling and conditioning of the concentrate suitable for disposal as LLW.

The Pre-Construction Safety Report (PCSR) was reviewed by the Nuclear Installations Inspectorate (NII) and agreement to proceed with construction was given in October 2003.

Key programme dates are now:

- May 2004 – building will be ready for the installation of process plant and equipment
- December 2004 - start of commissioning
- May 2005 – start of 12-month period for ‘demonstration of operation’

Contract Arrangements and Project Management

The project is now half way through the main implementation phase and is still on programme and budget.

This is the result of the teamwork approach adopted by RWE NUKEM and AWE. Good project management techniques and communications, design control and interface management have been established. Considerable effort has been put into definition exercises to cover all aspects of the project and this has helped maintain the fast track programme.

Interactive review techniques have been utilised to reduce approval times that often delay projects of this nature.

The contract is incentivized to ensure both parties gain equally from the benefits of the proactive partnering approach.