

## **UNDERGROUND RADIOACTIVE WASTE STORAGE TANK SAMPLER**

E. J. Cruz

Vista Engineering Technologies, LLC

8203 West Quinault Avenue, Building C, Suite 200, Kennewick, WA 99336

### **ABSTRACT**

Hanford's River Protection Project has 177 underground waste storage tanks. These tanks hold a wide variety of mixed hazardous and radioactive waste that come from a variety of research and development, fuel reprocessing, and plutonium production activities. The tanks range in size from fifty-five thousand to over one million gallons in capacity. The composition of waste in these tanks varies significantly. There are several sampling tools in use at the site today. None of them are adept at obtaining samples when there is only a shallow (~1") layer of waste. A sampler designed for shallow layers of sludge, saltcake, or liquid was required to support tank closure activities underway at Hanford.

Vista Engineering developed a concept for a clamshell sampler that would be very capable of taking shallow layer waste samples and obtaining discrete samples from a specific depth. This sampler has been designed, fabricated, and tested on a variety of simulated waste.

The clamshell sampler was developed for the Hanford radioactive mixed waste tank environment. Most of the sampler, and all of the waste contacting surfaces, are constructed of stainless steel. This limits the potential for corrosion. The sampler is operated pneumatically which increases survivability and eliminates the ignition source potential resulting from electric motors. The use of rapidly removable and replaceable clamshells enables the user to take multiple samples during a single campaign. A glove box deployment system was designed to minimize worker dose and potential to exposure as well as facilitate rapid deployment of the sampler while minimizing setup and takedown costs.

The sampler was the subject of extensive acceptance and performance testing on a variety of simulants in May 2003. Varying shear strengths, densities, and simulant depths were included in the testing. In nearly all conditions, the sampler was successful. Some minor design changes to facilitate operation were incorporated as a result of testing. The glovebox deployment system design and fabrication was initiated in late August 2003 and delivered in ten weeks along with two samplers and twenty-one clamshell sets. The integrated "Below-Riser Clamshell Sampler System" was first deployed in November 2003 on Tank C-106.

This sampler is expected to provide critical data for tank closure activities at Hanford. The current configuration is suitable for sampling along a single vertical axis. Addition of a remotely operated platform will allow sampling across the entire tank bottom. The clamshell sampler system is a demonstrated technology capable of recovering samples in difficult conditions. This new capability will translate to higher confidence in the tank residual inventory and in risk assessments that use the data. High confidence in inventory and risk assessment information enables technically defensible tank closure decisions and facilitates required regulatory approval.

### **INTRODUCTION**

Hanford's River Protection Project has 177 underground radioactive waste storage tanks. These tanks hold a wide variety of mixed hazardous and radioactive waste that come from a variety of research and development, fuel reprocessing, and plutonium production activities. The size of the tanks ranges from fifty-five thousand to over one million gallons in capacity. The composition of these tanks varies

significantly. There are several sampling tools in use at the site today. None of them are adept at obtaining samples when there is only a shallow (~1") layer of waste. A sampler designed for shallow layers of sludge, saltcake, or liquid was required.

Sampling methods at Hanford include:

- **Grab Sampling:** A rig consisting of a weighted stainless steel bottle cage, sample bottle, and stopper on a tether is lowered into the tank. When the desired depth is reached, the stopper is removed using a second cable and waste flows into the bottle. The method is relatively easy and inexpensive to deploy and is capable of gathering large sample volumes (~32 ounces). Discrete depth sampling is difficult to achieve since the bottle is open during retrieval. The sampler is not adept at taking samples from shallow waste depths and from extremely viscous or hard materials. This is because the sampler requires the waste to flow into the bottle.
- **Finger Trap Sampling:** A rig consisting of a stainless steel cylinder with an open end is lowered into the tank on a tether. The bottom end of the cylinder has a one-way valve constructed of radial overlapping, thin gage, stainless steel plates that allow material to pass into the sampler and prevent it from falling out. A plunger allows the sample to be extracted. The method is relatively easy and inexpensive to deploy and adept at taking sludge or saltcake samples. The sampler is limited to materials that will not flow out of the bottom of the sampler.
- **Core Sampling:** A specialized truck is used to push a threaded rod into the tank waste. The end of the rod has a sampling chamber on it. The method is adept at taking samples from discrete depths and in a variety of materials (e.g., liquids, sludges, saltcakes). The method is comparatively expensive; approximately six times the cost of the grab or finger trap methods and more time consuming. Additionally, the sampler is restricted to depths just above the tank bottom to prevent damage to the tank.

Each of these methods is adept at a particular application, but none are suitable for sampling thin layers from the tank bottom.

## **BELOW RISER CLAMSHELL SAMPLER BACKGROUND**

Working with CH2M Hill, a sampler was designed and tested for shallow layer sampling: the below-riser clamshell sampler (clamshell sampler). The clamshell was originally commissioned to meet the requirements of the C-106 Tank Closure Project and for broad applicability for other tanks. An additional goal of supporting discrete depth sampling was also incorporated to provide a lower-cost alternative to core sampling when high-quality discrete depth samples are required.

Clamshell-style samplers are not new. Clamshell samplers are used for marine, petrochemical and environmental applications. The Savannah River Site uses a brass clamshell sampler modified for use in radioactive waste tanks. The Extended Reach End Effector (EREE) was developed by Pacific Northwest National Laboratory for the Light Duty Utility Arm (LDUA) but never deployed. The EREE sampler used removable clamshells with a 50 ml capacity. The EREE sampler was never deployed, but the extensive testing provided confidence that the concept would be successful.

## **DESIGN CRITERIA**

Design criteria for the sampler were established to support sampling in a wide variety of conditions. A design requirements document was prepared to describe the functions of the clamshell sampler, identify

the requirements necessary for the sampler to carry out its function, and document the basis for the engineering and design of the sampler. Key design requirements include:

- Below riser sampling via a 4-inch schedule 40 riser.
- Suitability for use in the Hanford tank environment:
  - Radiation fields of 500 Rad per hour
  - PH of 4-14
  - Temperature of 15°C (60°F) to 93°C (200°F)
- Collection of 50-100ml samples of liquid, sludge, and solid material
- 50 lbs of closing force applied to clamshells
- Stainless steel exterior (for waste contacting surfaces)
- Cost-effective design
- Capable of reaching 60 feet below the riser face
- Consistent with ASTM and SW-846 guidance
- Compatible with existing characterization infrastructure
- Reusable
- Quick-release of scoops from the sampler body.
- A deployment system suitable for use in a glove bag or glove box including a line counter.

Goals for the design included:

- Maximize the use of existing Hanford sampling infrastructure and support equipment
- Maximize use of off-the shelf components and equipment
- Facilitate use of different clamshell designs and configurations.

## **PROTOTYPE DESIGN AND FABRICATION**

The sampler design was initiated in March 2003. The mechanical design was based on a concept developed by Vista Engineering for a pneumatically driven clamshell sampler that used dovetail fixtures for installation and removal of sample jaws. A prototype deployment system including umbilical management and pneumatic supply was also designed. Early mechanical engineering work focused on developing an initial design to enable production of a plastic prototype. Preliminary calculations and design work were used to develop the first complete solid model using Solidworks software. The solid model was transmitted electronically (no drawings were produced) to a vendor who produced a plastic

prototype using stereolithography. The plastic prototype was assembled in less than one week. The plastic prototype was used to examine critical interfaces, confirm the mechanical calculations and to identify issues that would make the sampler difficult to operate in the field. The plastic prototype proved to be a valuable exercise for the design team and the end users. Several suggestions and refinements were incorporated into the design as a result of the plastic prototype. Design and fabrication of the initial prototype sampler and deployment system was completed in May 2003.

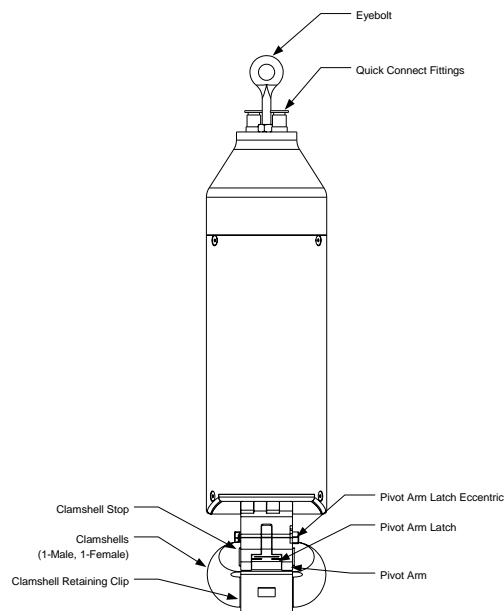

Fig. 1 Clamshell sampler

The sampler design is extremely simple and robust. Dovetails on the clamshells slide into mating dovetails on the bottom of the sampler. This method of attachment was used because it provides a very reliable and positive means of attachment. A pair of eccentric-driven latches provides clamping force to retain the clamshells in the dovetails. The clamshells are driven by a scissor linkage to provide additional clamping force. The scissor linkage is coupled to a stainless steel pneumatic cylinder that also serves as a structural member for the remainder of the sampler. The two-piece outer cover of the sampler is sealed with EPDM o-rings. A purge feature is also included to prevent contamination into the sampler body. The sampler is connected to an umbilical consisting of a stainless steel rope, two Nylon-11 tubes, and a neoprene heat-shrink cover. The initial prototype deployment system used a direct-driven, hand crank hose reel with a friction brake. A friction-driven line counter was also incorporated. All features were designed for minimizing maintenance and for rapid replacement in the event of failure. fixtures located at the bottom of the sampler operate in a mode similar to other sampling tools. The sampler is lowered into the tank using a hand crank connected to a hose reel with valves to supply air to the pneumatic cylinder and to relax the pressure to facilitate clamshell removal and installation. The sampler has smooth surfaces and no protrusions to minimize potential for contamination buildup and for lodging in the riser. The clamshell sampler is designed to fail safe (e.g., closed).

Clamshells are designed to retain liquids, sludges and saltcakes. An o-ring seal has been included. The clamshells are constructed of stainless steel has smooth surfaces and no protrusions to minimize potential for contamination buildup and to facilitate decontamination for re-use. A clip has been designed to keep the clamshells closed during installation, removal, and transportation. Currently, only 64 ml clamshell assemblies (male scoop, female scoop and scoop clip) are available, but plastic prototypes for 100 ml

clamshells have been produced. The dovetail attachment feature will accommodate a variety of clamshell styles (e.g., serrated openings), materials, and sizes.

### **PROTOTYPE TESTING**

Testing was conducted at the Hanford Cold Test Facility. Test objectives included:

- Demonstrate the capability of the grab sampler to collect about 150 g of waste from about 1" depth layer, below a 4" riser
- Demonstrate the robustness of the equipment and its flexibility in operation
- Familiarize the end users with the equipment.

A series of tests were conducted. The tests progressed from demonstrating basic functionality to performance testing with different simulants. Test activities included:

- Sealing of the clamshells (water leakage and intrusion of water while submerged)
- Deployment system operation (braking, raising/lowering of the sampler, line counter)
- Air consumption of sampler
- Safety interlocks and failure modes (e.g., loss of pressure)
- Installation and removal of the clamshells
- A drop test of the clamshells assembled with the retaining clip (to determine if the clip would keep the clamshells closed)
- Deployment system functionality
- Setup and takedown of the system.
- Sampling from shallow (~1/4") and deep simulant depths.

Seven simulants were selected to represent a range of conditions and wastes anticipated to be present at the time of tank closure. Simulant development and recipes were based on prior work for cold testing of the Mobile Retrieval System. Brief simulant descriptions are as follows:

- Simulant 1 was a basic soft and somewhat sticky mixture with fine particle size up to 3 microns.
- Simulant 2 had a soft, smooth and lightly elastic texture. The addition of sand and barium sulfate resulted in a heavier mixture with a variety of particle sizes.
- Simulant 3 was stiffer with larger particles resulting from the sand.
- Simulant 4 was very stiff with a variety of particles sizes.

- Simulant 5 was designed to emulate hard heel material. The simulant was grainy and breakable.
- Simulant 6 was a dry mixture simulating residual material in nearly empty tanks.
- Simulant 7 was pure water.

The simulant recipes are shown in Table 1. During testing, the measured shear strengths varied considerably from the calculated values. The observed consistencies were similar to those described above. The maximum measured shear strength during testing, 5420 Pa, was achieved with a modified version of Simulant 2. Simulants 5 and 6 provided a difficult, hard surface for the sampler for testing.

Table I Sampler testing simulant recipes

<b>Simulant</b>	<b>1</b>	<b>2</b>	<b>3</b>	<b>4</b>	<b>5</b>	<b>6</b>	<b>7</b>
Kaolin	50	34	29	29		30	
Plaster of Paris		9	12	12		15	
Sand		8	8	15	79.5	20	
Barium Sulfate		3	9	9			
Iron Oxide						25	
Fly Ash					5.9		
Cement					0.9		
Water	50	46	42	35	13.7	10	100
Calculated density (g/cm <sup>3</sup> )	1.45	1.54	1.67	1.80	2.2	2.96	1.00
Approximate Shear Strength (Pa)	180	500	1200	7,000	46,000	N/D	
Notes:							
1. Values in % weight							
2. Shear strength is measured or estimated							
3. N/D: Not Determined							

## TEST RESULTS

The sampler performed extremely well during three days of testing. The sampler was able to fill the sample jaws from layers as thin as 1/4" with water and sludge simulants. Observed areas of bare metal were present in the test bed during thin layer sampling. Sampling in deeper simulant beds resulted in excellent recovery as well. During drop testing, a small amount of leakage (~4-6 ml) was experienced. The most significant observation regarding performance of the system was difficulty in fully closing the clamshells with Simulant 6. This simulant demonstrated a significant compressive strength and very little resistance to shear forces. The prototype clamshell design included parallel mating surfaces around the perimeter of the male and female clamshells. This area compressed a small amount of simulant which prevented the clamshells from closing completely: a gap of ~1/8" was observed during testing. Lastly, the clamshell installation, removal, and retention functionality was inconsistent: the clamshells were either too loose or too tight.



Fig. 2 Shallow layer sampling test example

Some operational improvements were suggested as well. CH2M Hill operations staff requested that the clamshell removal be modified to allow more rapid removal of the clamshells. Additionally, several suggestions were made regarding the deployment system. A revised cranking system that would use both hands and require less effort (using a winch or gear reduction). The operators requested a braking system similar to the ratcheting winches used on the finger trap and grab samplers. Most significantly was the request to incorporate the system into a re-useable glove box. This would reduce the dose to the sampling crew, minimize potential for exposure, and reduce cost through the re-use of equipment. Grab and fingertrap sampling operations usually require disposal of the glove bag, deployment winch, and sampler.

### **DESIGN MODIFICATIONS & GLOVE BOX**

Three changes were incorporated into the sampler design as a result of the testing. The latching system for the clamshells was modified to allow more travel and clamping force. This change enabled adjustment of the tolerances for the clamshell dovetails and the incorporation of a slight lead-in to facilitate installation and removal. The revised design requires additional time to align the latching mechanism prior to installation but facilitates faster removal. This is acceptable due to the increased hazard resulting from the waste in the clamshells after a sample has been obtained. The third change was to remove the parallel mating surface from the male clamshell. The revised design eliminated the pinch point where simulant prevented the clamshells from closing during testing.

The most significant change to the system was the decision to develop a purpose-built glovebox and deployment system for the sampler. During the summer of 2003, a suggestion was made to investigate the possibility of using a surplus glovebox from another facility on the Hanford Site. This suggestion proved to be extremely valuable due to the significant cost and schedule penalty associated with designing and building a new glovebox. The Fuels and Materials Examination Facility (FMEF) was the location of a never-used system that included numerous gloveboxes. The project team visited the FMEF and selected a glovebox for the sampler.

In late August 2003, the design of the new deployment system was initiated with a goal of delivering the finished "Below-Riser Clamshell Sampler System" for testing in 6 weeks. The schedule required numerous activities to be performed in parallel, including the design, procurement, and fabrication activities. Additionally, the short schedule required the design to maximize the use of off-the shelf equipment.

Design requirements for the system included:

- HEPA inlet/breather filtration
- Fabrication of stainless steel to maximum extent practical
- Forklift and crane lifting capability
- Adjustable height
- Capability to store the sampler when not in use
- Fixture for gas/vapor sampling in the glovebox
- Spray wash capability to decontaminate the sampler and glovebox
- Drip pan to prevent liquid buildup in glovebox.

The glovebox was refurbished to facilitate the new mission. New windows and seals were selected and unneeded penetrations sealed. The glovebox has lead shielding sandwiched between stainless steel sidewalls. This configuration prevented any welding on the sidewalls.

The deployment system was changed significantly from the prototype. A bicycle-crank style mechanism was incorporated to ease the cranking load. This mechanism used ball bearings and rotating handles to reduce effort and prevent pinching or binding of the gloves. The crank mechanism was connected to a modified winch. The winch, typically used for vertical lifting applications, includes an automatic brake. The winch design modifications included incorporation of a gear belt drive pulley (replacing the wire rope) and a coupling to connect the winch to the bicycle crank mechanism. A dual output hose reel was modified to incorporate a gear belt pulley and eliminate the spring return mechanism. The hose reel was connected via stainless steel tubing to a valve panel located near the crank mechanism. A 4-port crossover valve is used to direct air to the open/close function of the sampler and to vent the side not in use. A shutoff valve is also provided. The shutoff valve provides local isolation (to prevent inadvertent operation) and to allow full relaxation of the sampler to facilitate installation/removal of the clamshells. The umbilical is connected to the hose reel using quick disconnect fittings to facilitate replacement. Pulleys mounted on the glovebox roof route the umbilical away from the operating area. A friction driven counter, identical to the original prototype deployment system, is mounted above the working area. A spray wand designed to support use of warm, pressurized water (~130 F, 1500 psi) for decontamination. A pair of HEPA filters was installed on the glovebox roof. A knife gate valve was installed to provide a clear pass through to the tank riser. Double check valves and isolation valves are included for the compressed air and water feeds. A single isolation valve is used for the HEPA filters and vapor/gas sampling port. The system passed a vacuum leak test and functional test prior to delivery.

The glovebox is supported by a carbon steel platform with forklift fixtures, adjustable legs, and lifting eyes. A sliding tube and pin arrangement and threaded adjusters allow for independent adjustment of the glovebox legs over 11" inches of travel. The glovebox platform is designed to eliminate the need for anchorage and to be resistant to overturning.

Procurement for all major components was completed within two weeks and in advance of design completion. Careful integration of the design activities was required to prevent issues during the



fabrication. Design reviews were also conducted in parallel. The careful coordination and communication resulted in very few modifications to the design.

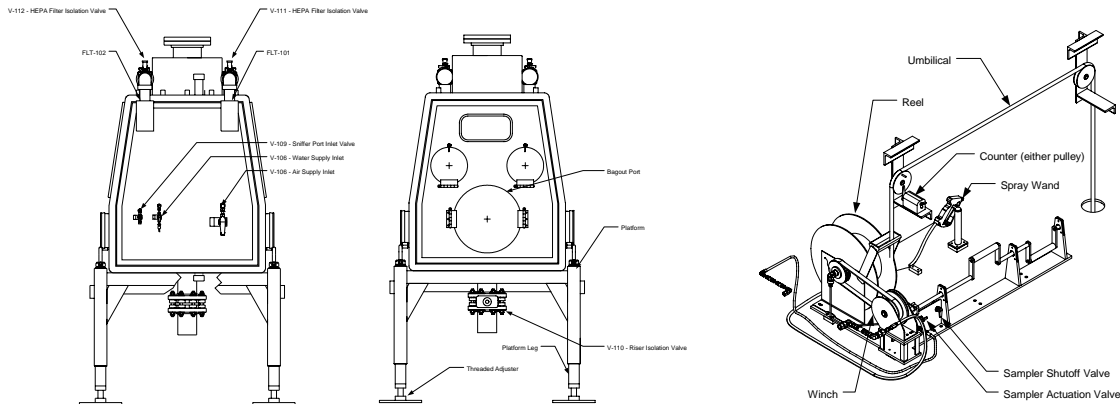

Fig. 3 Below-riser sampler system features

Two samplers and twenty-one clamshell sets were fabricated in parallel with the glovebox design and fabrication. Nineteen clamshell sets were cleaned and packaged to meet requirements for sampling. The glovebox deployment system, samplers, and clamshell sets were delivered on November 6, 2003 (ten weeks from the project start). A complete documentation package was also supplied including design media, calculations, and an operations & maintenance manual.

CH2M Hill characterization staff conducted training with the complete system for three days at the Cold Test Facility. A kaolin clay and water simulant was used. Some minor adjustments and two minor repairs (broken pivot arm latch eccentric, crank shear pin) were made. No design modifications were required and all training was completed successfully.

## FIRST DEPLOYMENT

The first deployment of the sampler at Tank C-106, Riser 14 was on November 21, 2003. The finger trap sampler had been deployed in the same location but was unable to obtain any material. The target waste was sludge covered with a relatively small liquid layer. The intent of the sampling event was to recover solids to enable risk assessment analysis required for closure of the tank.

The first event was only partially successful. First, elevated organic levels were detected in the glovebox. This was later attributed to the presence of adhesives, polymers, and residue from the acetone used to clean the glovebox. Secondly, the procedure for removal of the clamshells after sampling was modified in a way that resulted in loss of the sample material. The procedure was revised to ensure the close function would remain activated prior to installing the clamshell retaining clip and releasing the clamshell latches. The sampler was able to recover a sample of solids and liquids and no failures occurred. However, the loss of the sample material was significant enough that a second attempt was required.



Fig. 4 Interior view of completed below-riser clamshell sampler system

A second attempt was made on December 2, 2003 at the same location. During this attempt the sampler was deployed into the same sludge, but water additions to the tank increased the liquid depth by several inches. During this attempt, a nearly full sample was obtained and retrieved into the glovebox. However, some liquid was observed when the sampler was tilted for removal of the clamshells. The clamshells appeared tightly closed. When opened, the clamshells were full of a thick, clay-like material. The sample was not sent to the laboratory since no suitable plastic containers were available at the time. The use of glass in gloveboxes is limited due to concerns regarding broken glass and the polymer gloves used. Due to schedule interfaces with other projects (the riser was scheduled for equipment installation later that day), there was insufficient time to recover a suitable container so the material could be shipped to the laboratory for analysis. Some portion of the observed leakage may have come from the clamshells. Overall, the event demonstrated the sampler is effective at recovering samples from difficult to sample materials and easily operated in the field.

## SECOND DEPLOYMENT

The second deployment of the sampler was on January 30, 2004. Over 200g of solid material was recovered from a second riser on Tank C-106. A minimum of 200g was required to support analyses specified in the data quality objective for the sampling event. According to site personnel, a total of nine clamshell sets were used with the first few sets being largely full of solids. Sampling procedures were modified to use a plastic bottle to hold the full clamshells after removal from the tank. No operational or safety issues were noted during the sampling event.

The material remaining in C-106 has been subjected to both hydraulic and chemical retrieval campaigns over the last year. The remaining waste is likely to be relatively loose. It is reasonable to believe that the

first clamshell set created a divot and subsequent clamshells placed in the same location were unable to gather as much waste. Preparations for a similar campaign at Tank S-112 later this year are underway.

## **LESSONS LEARNED**

Overall, the sampler effort has been very successful. The original sampler prototype design was largely successful and required very little revision to become a final product. The project was completed to meet a very demanding project schedule and complex requirements. Careful coordination and communication between involved parties was the single largest factor contributing to the success of the effort. Engineering, operations, vendor, safety, radiation control, and environmental organizations were all represented during the project.

Opportunities for improvement include broader involvement of operations staff and additional practice/testing time. The operations staff has a wealth of experience with sampling equipment and is the end user for the equipment. Nearly all design changes and many design features for this effort are a result of their suggestions and requests. Operations suggestions and requests positively impacted the safety, ease of operation, and performance of the equipment.

Additional practice time with a wider range of simulant (including combinations of liquid above a hard heel) above would have likely revealed that the clamshells may not seal tightly in all applications. This is an inherent feature of the clamshell design and the intended application. The clamshell design was re-reviewed to determine if any features could be added or eliminated to improve sealing. While some changes could improve sampling in some conditions (e.g. hard sludges) they are likely to negatively affect sampling in others (e.g., liquids). Tank heels are expected to be some of the hardest material in the Hanford tanks and traditionally have been the site of a significant amount of debris. Debris could also prevent sealing of the clamshells. With these considerations in mind, the additional practice would have revealed the need to plan and practice for clamshell leakage during operations.

This effort has been very successful in making changes on a very short basis to incorporate lessons learned to date. In fact, the operation procedure was revised and approved between the initial sampling attempts. Additional experience with the equipment and a continued commitment to improvement will pay future benefits in performance and safety of the effort.

## **SUMMARY**

Vista Engineering developed a concept for a clamshell sampler that would be very capable of taking shallow layer waste samples and obtaining samples from a specific depth. This sampler has been designed, fabricated, and tested on a variety of simulated waste. The entire project was conducted to meet difficult technical and performance requirements on a demanding schedule.

The clamshell sampler system was developed for the Hanford tank environment. Most of the sampler, and all of the waste contacting surfaces, are constructed of stainless steel. The sampler is operated pneumatically which increases survivability and eliminates the ignition source potential. The use of rapidly removable and replaceable clamshells enables the user to take multiple samples during a single campaign. A glove box deployment system was designed to minimize worker dose and potential to exposure as well as facilitate rapid deployment of the sampler while minimizing setup and takedown costs.

The sampler was the subject of extensive acceptance and performance testing on a variety of simulants in May 2003. Varying shear strengths, densities, and stimulant depths were included in the testing. In nearly all conditions, the sampler was successful. The integrated system was first deployed in November

2003 on Tank C-106. The clamshell sampler was successful in obtaining a sample when other available methods were not. Both attempts resulted were successful in obtaining samples. Future deployments are scheduled for the sampler system starting in January 2004 to support tank closure initiatives.

Based on the results to date, there is a high degree of confidence the clamshell sampler will provide critical data for tank closure activities at Hanford. The current configuration is suitable for sampling along a single vertical axis. Addition of a remotely operated platform (Vista Engineering has already developed a concept) will allow sampling across the entire tank bottom. The clamshell sampler system is a demonstrated technology capable of recovering samples in difficult conditions. This new capability will translate to higher confidence in the tank residual inventory and in risk assessments that use the data. High confidence in inventory and risk assessment information enables technically defensible tank closure decisions and facilitates required regulatory approval.

Vista Engineering Technologies, LLC has a team of experienced professionals who possess a clear understanding of the design, fabrication, and operation of equipment in challenging environments. Vista Engineering has a solid track record in technology adaptation, as well as in delivering field deployable technology solutions to clients. The sampler and clamshells are currently available for sale to the general public at published prices.

For more information, email the author at [cruz@vistaenr.com](mailto:cruz@vistaenr.com), or call (509) 737-1377.

## **ACKNOWLEDGEMENTS**

The author would like to thank the CH2M Hill staff and organizations who are the sponsors, customers, and end-users for the system.

## **REFERENCES**

- 1 Acceptance Test Procedure for the Clamshell Sampler, RPP-16598, Rev. 1, Kabage, P.A., CH2M Hill Hanford Group, Inc. (2003)
- 2 Acceptance Test Report for the Clamshell Sampler, RPP-17966, Rev. 0, Kabage, P.A., CH2M Hill Hanford Group, Inc. (2003)
- 3 Design Specifications for the Below-Riser Clamshell Sampler, VET-F&R-1168-01, Revision 1, Vista Engineering Technologies, LLC, (2003)
- 4 Specification for the Below-Riser Sampler Subsystem, RPP-17963, Rev. 0, CH2M Hill Hanford Group, (2003)
- 5 Technology Demonstration Fact Sheet: Extended Reach End Effector, Fluor Hanford Corporation (2001)