

**SUCCESS IN MANAGING WASTE WITH NO IDENTIFIED PATH TO DISPOSAL  
AT THE IDAHO NATIONAL ENGINEERING AND ENVIRONMENTAL  
LABORATORY  
(Previously Termed Special Case Waste)**

Carlan K. Mullen, Mike L. Carboneau, Max R. Leavitt  
Bechtel BWXT Idaho, LLC  
Idaho National Engineering and Environmental Laboratory

**ABSTRACT**

The Idaho National Engineering and Environmental Laboratory (INEEL) is aggressively managing waste with no identified path to disposal (WNPDP), which was previously termed special case waste (SCW). As a result of several years of this aggressive management, the INEEL has reduced its WNPDP volume from approximately 38,000 m<sup>3</sup> in 1993 to approximately 6.33 m<sup>3</sup> in 1999. This paper discusses how the INEEL reduced its WNPDP volume. It specifically discusses the beryllium reflector waste produced from the Advanced Test Reactor (ATR) as an example of the INEEL's success in managing its WNPDP.

The INEEL's success in reducing its WNPDP volume is the result of establishing long-range strategic objectives and consistently allocating an annual budget to implement specific work tasks that are consistent with these objectives. In addition, specific short- and long-range work tasks were developed and documented in work control documents. The work tasks are evaluated annually for consistency with the strategic objectives.

Since the INEEL has successfully reduced its WNPDP volume, it is now focusing on disposing of the remaining volume and preventing future generation of WNPDP. As a result of this focused effort, a life-cycle disposal plan was developed for the Advanced Test Reactor (ATR) beryllium waste. This plan covers beryllium reflectors currently stored in the ATR canal and beryllium reflectors generated through 2050. This plan includes a pollution prevention (P2) opportunity, which applies to the DOE complex reactor beryllium reflector waste stream. The P2 opportunity also contributes to planning for the international nuclear industry to extend the life and reduce the radionuclide activation of nonfuel material in existing and newly developed test reactor nuclear power systems.

In Fiscal Year 2000, the INEEL is focusing on further reducing its WNPDP volume. To completely dispose of the INEEL WNPDP, it will need a national plan for disposing of some WNPDP categories. Therefore, the INEEL WNPDP Program is participating in the DOE complex integrated planning process for legacy and future generated WNPDP waste.

**INTRODUCTION**

The Idaho National Engineering and Environmental Laboratory (INEEL) has aggressively managed waste with no identified path to disposal (WNPDP), previously termed special case waste (SCW), for many years. As a result of several years of this aggressive management, the INEEL reduced its WNPDP volume from approximately 38,000 m<sup>3</sup> in 1993 to approximately 6.33 m<sup>3</sup> in 1999. The INEEL's success in managing and reducing the WNPDP was the result of establishing long-range strategic objectives and consistently allocating an annual budget to implement specific work tasks consistent with the objectives. These objectives were documented in *Waste Management Tactical and Strategic Plan* (DOE/ID-10664, November 1998) and in specific WNPDP project management plans. Specific short- and long-range work tasks were developed and documented in work control documents, which are evaluated annually for consistency with the strategic objectives.

Overall, variations in Waste Management budget priorities have caused variations in work priorities; however, the WNPD-allocated budget has been sufficient to provide continuity in management and technical planning, inventory maintenance, and WNPD awareness across the INEEL site.

A specific WNPD waste, beryllium reflector blocks from the Advanced Test Reactor, illustrates how focused waste planning can lead to a difficult waste stream disposal plan with pollution prevention opportunities.

## **DEVELOPING WNPD OBJECTIVES**

Waste with no identified path to disposal does not fit into the major waste type disposal paths. These wastes were excluded from the major waste type disposal paths because of their chemical or radiological characteristics, form, size, ownership, or regulatory requirements. As a result, the INEEL experienced years of frustration in disposing of its WNPD. It was recognized that these difficult waste streams were in storage containers, remained in facilities, and would continue to be generated from operations and future decontamination and decommissioning. It was also understood that waste disposal priority and funding was and would likely continue to be directed toward the major waste types and that the difficult waste streams may be disposed of much later as a separate waste type at significantly higher costs.

The traditional method to secure funding for disposing of WNPD consisted of: identifying the problem; developing work scope, cost estimates, and schedules; preparing a program; and requesting funding. Unfortunately, the traditional method was not successful in establishing a priority for securing funding. Although regulatory drivers exist to manage these wastes, they do not impose that funding be prioritized to dispose of them. Consequently, funding would be available for disposing of WNPD only when the waste presented an immediate unacceptable environmental release risk or when ongoing operations were impacted. It was recognized that WNPD awareness needed to be continually elevated to management awareness in order to take advantage of opportunities to dispose of WNPD along with the major waste types.

In 1993, waste type managers evaluated the WNPD issues. After identifying and understanding the magnitude of the waste problem, they determined that an alternate method was needed to successfully dispose of WNPD. As a result, they developed a new WNPD management strategy that focused on the similarities (rather than the differences) between the existing major waste types and the difficult waste streams and the existing specific programs to manage them. They formulated six life-cycle guiding strategy objectives as follows:

- Objective 1: Make maximum use of existing programs to manage WNPD that are of the same waste type
- Objective 2: Encourage existing programs to develop strategies to remove waste from the WNPD category
- Objective 3: Move and consolidate special performance assessment required (SPAR) low-level waste (LLW), which requires disposal in a deep geological repository, into long-term storage that is safe, compliant with applicable regulations, and minimizes cost
- Objective 4: Coordinate disposal of WNPD with similar waste types
- Objective 5: Characterize potential WNPD at the INEEL in order to estimate total WNPD for planning and decision-making

- Objective 6: Work with other DOE sites to develop strategies for disposing of SPAR LLW.

These six objectives continue to provide the overall management direction for disposing of INEEL WNPD.

### **DOE ORDER 435.1**

DOE Order 435.1, "Radioactive Waste Management," requires that plans be prepared for disposing of WNPD before it is generated. This order will strengthen the INEEL efforts to make maximum use of existing major waste type programs and encourage the development of program strategies to remove waste from the WNPD category before it is generated. This order places responsibility on waste generating programs and facilities to develop life-cycle planning for waste disposal during the initial program and facility planning. The DOE order is consistent with the six INEEL life-cycle guiding objectives established in 1993, and it supports current WNPD planning.

### **SPECIAL CASE WASTE: THE OLD TERM DEFINED AND SUBCATEGORIES**

In order to discuss the specifics of the INEEL WNPD successes, a brief description of the historical term "special case waste" (SCW) used at the INEEL is necessary. This term has also been used across the DOE complex, but it may have had slightly different meaning in actual practice. At the INEEL in 1993, the term SCW was defined as a waste type that generally could not be disposed of through an existing waste type process. Although most of the INEEL SCW inventory had characteristics that were similar to the major waste types, it was categorized as SCW if it did not have a current disposal path because of its specific characteristics, shape or size, ownership, or was suspect or uncharacterized. Based on these characteristics, the following subcategories of INEEL SCW were defined:

- Noncertifiable defense transuranic (TRU): This is transuranic waste generated by Defense programs that is not Waste Isolation Pilot Plant (WIPP) certifiable
- Non-defense TRU: This is transuranic waste generated by DOE Energy Research or a Nuclear Regulatory Commission licensee and stored at the INEEL
- Specific performance assessment required low-level waste: This is DOE greater-than-Class C equivalent waste requiring a performance assessment through the National Environmental Policy Act (NEPA)
- Site-specific disposal problem low-level waste: This is DOE LLW that does not meet the waste disposal acceptance requirements at the INEEL Radioactive Waste Management Complex
- Fuel and fuel debris: This is DOE-titled fuel and fuel debris from research or development projects.

Other DOE sites' inventories of SCW may be grouped differently than the above subcategories. This difference in definitions and grouping presents some problems in evaluating DOE complex inventories for national disposal planning.

## WNPD INVENTORY REDUCTION

In 1994 and 1995, the INEEL undertook a major effort to understand the characteristics and ownership of its WNPD and to evaluate the existing programs that generate and manage waste types. In addition, systems engineering approaches were implemented, waste management planning was integrated, and waste type managers were assigned. After identifying the characteristics of WNPD and integrating waste management planning, disposal opportunities were identified and integrated into the planning of similar waste types. As a result, WNPD volume was reduced. Figure 1 illustrates INEEL total volume reduction by year.

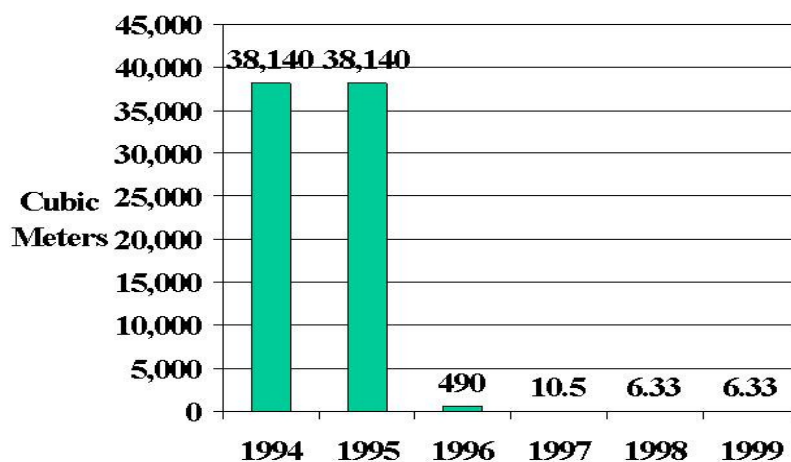

Fig. 1. SCW Inventory Reduction

In addition to reducing waste volume, two SCW subcategories were eliminated and other subcategories were significantly reduced over the last 5 years using the same approach. Noncertifiable transuranic low-level waste (low-level alpha) was integrated into the Advanced Mixed Waste Treatment Program, thereby eliminating 29,000 m<sup>3</sup> of WNPD. In addition, stored TMI-2 fuel and fuel debris were incorporated into the State of Idaho Governor's Agreement, thereby eliminating 237 m<sup>3</sup> of WNPD. This agreement directs that fuel and fuel debris in wet storage be placed in interim dry storage and that the material be removed from the State of Idaho by 2035. Programs are currently funded and progressing to complete disposal of these previously identified and inventoried WNPD wastes streams.

After disposing of these WNPD volumes, a more focused effort on disposing of the remaining volumes has resulted. The remaining volumes generally were not sufficiently characterized to allow final waste type determination. These remaining volumes are termed "potential WNPD." Over the past 3 years, historical, technical, and available characterization information was collected and evaluated to determine if waste disposal decisions could be made. Studies, evaluations, and value engineering sessions were conducted to identify interim storage options for SPAR at the INEEL until a national

geological repository is available. As a result of these efforts, WNPDP volume was further reduced to 10.5 m<sup>3</sup> in 1997 and 6.33 m<sup>3</sup> in 1998. In addition, remaining wastes requiring further characterization were identified. These reductions, though not as dramatic as earlier reductions, are still significant because of the difficulty of disposing of these wastes. Much of this later volume reduction resulted after determining that SPAR LLW in nuclear test reactors did not have the high enough power history to generate greater-than-Class C radionuclides and after refining volume estimates from a detailed technical assessment of the potential WNPDP component configurations.

The current remaining 6.33 m<sup>3</sup> inventory has insufficient characterization and historical data to make waste planning determinations. The waste streams that make up the remaining volume are the focus of future WNPDP planning efforts

In Fiscal Year 1998, WNPDP planning and nuclear operations were integrated. As a result, the focus is on detailed characterization of the legacy waste. Legacy wastes are wastes that are containerized or uncontainerized and have been generated in the past. They are located in controlled storage or remain in the generating facility. The characterization information and process knowledge from this waste stream will provide data to make waste determinations, continue waste disposal planning, and support future waste disposal planning. Future waste characterization is not anticipated.

The initial sealed source inventory identified approximately 88 radioactive sealed sources as potential greater-than-Class C material. These sources were also identified as not in use. After detailed evaluation, it was determined that 46 of the sealed sources were in use and four were on loan to off-INEEL users. Since 50 of the original 88 sealed sources are in use and not available for disposal, they were removed from WNPDP inventory. Also, four of 88 sources were not in use and will remain in the WNPDP inventory.

The remaining 34 sources are Cs-137 with no possibility for future use and are ready for disposal. The WNPDP Project Office evaluated these sources for possible disposal. They evaluated reuse, recycling, and disposal options. Reuse and recycling options were not available for these specially configured sources. Therefore, they determined that disposal was the preferred option.

A performance assessment (PA) was performed at the Radioactive Waste Management Complex (RWMC) to determine disposal options and any engineered measures required for disposal as contact-handled low-level waste at the Subsurface Disposal Area (SDA). It was determined that the sources could be disposed of there. A disposal plan and cost estimate were prepared and provided to the source custodian.

## **WNPDP CURRENT AND HISTORICAL DATABASES**

Two separate, but linked, databases were developed: a WNPDP Historical Database and a Current Database. These databases provide a very important tool for managing WNPDP. They will be used to analyze existing WNPDP waste stream information and to identify data gaps in existing information, which are necessary for waste type determination and planning disposal.

The Current Database contains information on the WNPDP inventory that remains without a disposition. The WNPDP Program actively focuses management attention and directs funding to address the information data gaps necessary to determine final waste types and dispose of that WNPDP. The database is reviewed to identify future work tasks and prepare funding requests annually. All WNPDP waste stream characterization, waste determinations, disposal determinations, and assessments and evaluations are documented either by reference or actual data on the Current Database. This database provides a one-stop information source for compiling, summarizing, and statusing INEEL WNPDP

information and for providing onsite and offsite data requests. The data cells are color coded to indicate if data is current, in the process of being collected, or is not yet available. If all the data fields are complete, there is usually sufficient information for a waste determination and disposal plan. The Current Database is linked to the Historical Database.

The Historical Database stores past information and references that document WNPDP management decisions. When the disposal plan is complete, the data for a waste stream is transferred to the Historical Database, where it remains as a record for future reference. It has been the INEEL's experience that occasionally after a waste stream is disposed of, it may return to the active WNPDP inventory as a result of a disposal facility waste acceptance change, improved characterization data, or a regulatory change.

These databases were effectively used as an assessment management tool to focus WNPDP Program characterization efforts on collecting data to make waste stream determinations for current WNPDP and to project future WNPDP.

### **ILLUSTRATIVE EXAMPLE OF INEEL WNPDP METHOD**

Once a comprehensive inventory of the INEEL WNPDP was completed and documented in the WNPDP databases, the data were analyzed to identify opportunities to manage the individual WNPDP waste streams consistent with the established strategic objectives. As a result, many of the WNPDPs were assigned to major waste streams. The WNPDP is inventoried annually, which continues to provide progress status of wastes assigned to the major waste streams and identification of new WNPDP.

It is important to continue to track WNPDP until it is disposed because WNPDP volumes can change. WNPDP volumes can change as a result of any of the following:

- Improved waste characterization, which identify characteristics that influence disposal
- Changes in treatment and disposal facility acceptance criteria and requirements, which influence disposal acceptance
- New laws and changes in regulatory requirements, which influence disposal acceptance
- New program waste generation
- Implementation of pollution prevention techniques, which can change future projected WNPDP volumes
- Changes in requirements, regulations or planning, which can result in WNPDP initially assigned to a major waste program once again becoming WNPDP.

As a result of annually reviewing the WNPDP inventory and evaluating and assigning the WNPDP to the major waste streams for management planning, the INEEL decreased its initial 1993 WNPDP volume. Therefore, the WNPDP Program is focusing on an ever decreasing waste volume each year.

As a result of the 1998 evaluation of the remaining WNPDP volume, an opportunity to resolve an INEEL operational waste problem and a legacy WNPDP disposal problem was identified. In 1999, the WNPDP Program focused its attention on disposing of the Advanced Test Reactor (ATR) beryllium reflector material waste. This waste is generated every 7 to 8 years at each reactor core-internal-change-out (CIC). Legacy beryllium reflector material is stored in the ATR canal awaiting a disposal path. In addition to storing this material, the ATR canal is needed to support continued reactor operations. The

ATR is planned to operate through 2050 and will generate eight reflector blocks and 16 outer shim control cylinders at each CIC. Six to 8 CICs will be required during the future ATR operating period. Current legacy beryllium in the canal consists of 12 beryllium reflector blocks and 39 outer shim control cylinders (Figures 2 and 3). Beryllium reflector material waste historically has been disposed at the INEEL RWMC as remote-handled low-level waste (LLW). Two concerns were identified with the historical disposals, which have prevented further disposal at the RWMC. The first concern resulted when improved characterization modeling indicated greater-than-Class C radionuclide concentrations in the beryllium materials, primarily carbon-14. The second concern resulted from detections of tritium releases to the soil near historical beryllium disposal locations. These concerns indicated that RWMC performance assessment limits may be exceeded in the future. Consequently, further disposal of the ATR beryllium material at the INEEL RWMC was subsequently prevented.

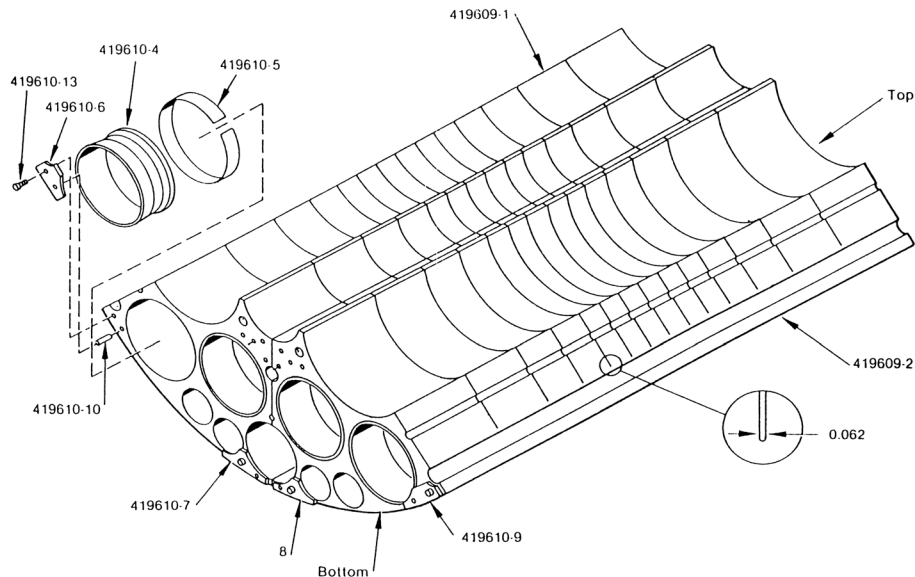

Fig. 2. Two Reflector Blocks Joined to Form One of Four ATR Reactor Quadrants

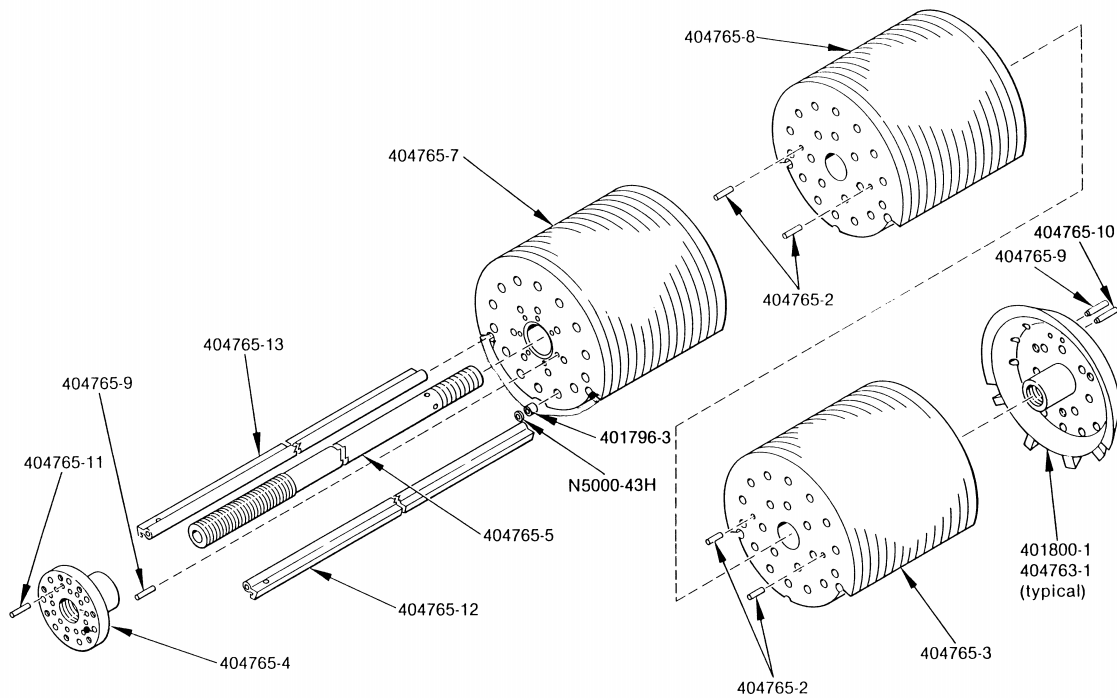

Fig. 3. Expanded View of One ATR Reactor Outer Shim Control Beryllium Reflector

Modeling for hard-to-measure radionuclides, which are greater-than Class C, is acceptable for providing waste characterization data for evaluating waste acceptance at the INEEL RWMC. The existing beryllium characterization data was analyzed, which indicated that carbon-14 is the primary radionuclide in the beryllium material, preventing disposal as Class C remote-handled low-level waste. The analysis also indicated that maximum ATR reactor core lobe power distributions and chemical impurity levels in the beryllium were used for modeling the radionuclide inventories in the reflector and outer shim control cylinders. This caused the radionuclide concentration summation-of-fractions for each of the 12 legacy reflector blocks to exceed the greater-than Class C limits. In addition, uncertainties in the modeling methodology presented further concerns because many of the calculated concentrations were close to the acceptable disposal limits.

Because of the initial conservatism (maximum power and chemical impurities) used in the computer model, it was determined that if specific reflector block characteristics could be found in the reactor operational documentation and used to model the radionuclide concentrations, then some of the blocks may meet disposal criteria.

Sufficient ATR operational process knowledge was found to justify using the specific CIC and power lobe data for each of the 12 legacy blocks. However, further investigation of the reflector block chemical assay data was not as successful. The chemical assay information did not contain nitrogen concentration data, important for calculating carbon-14 concentrations in beryllium. Without the nitrogen



data, all of the identified conservatisms could not be eliminated from the calculated radionuclide concentrations.

It was determined feasible to physically sample the 12 legacy blocks to determine the beginning of life nitrogen concentration. It was judged that a majority of the nitrogen in the beryllium originated in the initial beryllium ore (as beryllium-nitrides and nitrates) and would be uniformly distributed in the final machined reflector block. By analyzing irradiated samples from each of the blocks for carbon-14 and remaining nitrogen, the total nitrogen concentration of each block could be determined. With the total beginning of life nitrogen information, and specific lobe power information, the total carbon-14 in the 12 reflector blocks could be determined. This will provide specific data for waste stream determinations and disposal planning.

Irradiated beryllium is being sampled and analyzed during the first quarter of FY 2000, and the data results should be available during the second quarter FY 2000.

### POLLUTION PREVENTION OPPORTUNITY

As a result of planning for beryllium disposal, a pollution prevention (P2) opportunity was identified. This opportunity focuses on reducing radionuclides generated from the irradiation of beryllium reflector materials from future ATR reactor operation. The ATR, like many research reactors, uses beryllium reflectors to enhance neutron flux densities in the core. The core design allows flexibility and variability for lobe megawatt day (MWD) power exposure. This unique reactor core design results in variable beryllium reflector exposures. Figure 4 provides a schematic plan view of the ATR reactor four power lobe core design. Figure 4 also provides a picture of one machined reflector block used to make up the eight-reflector block core.

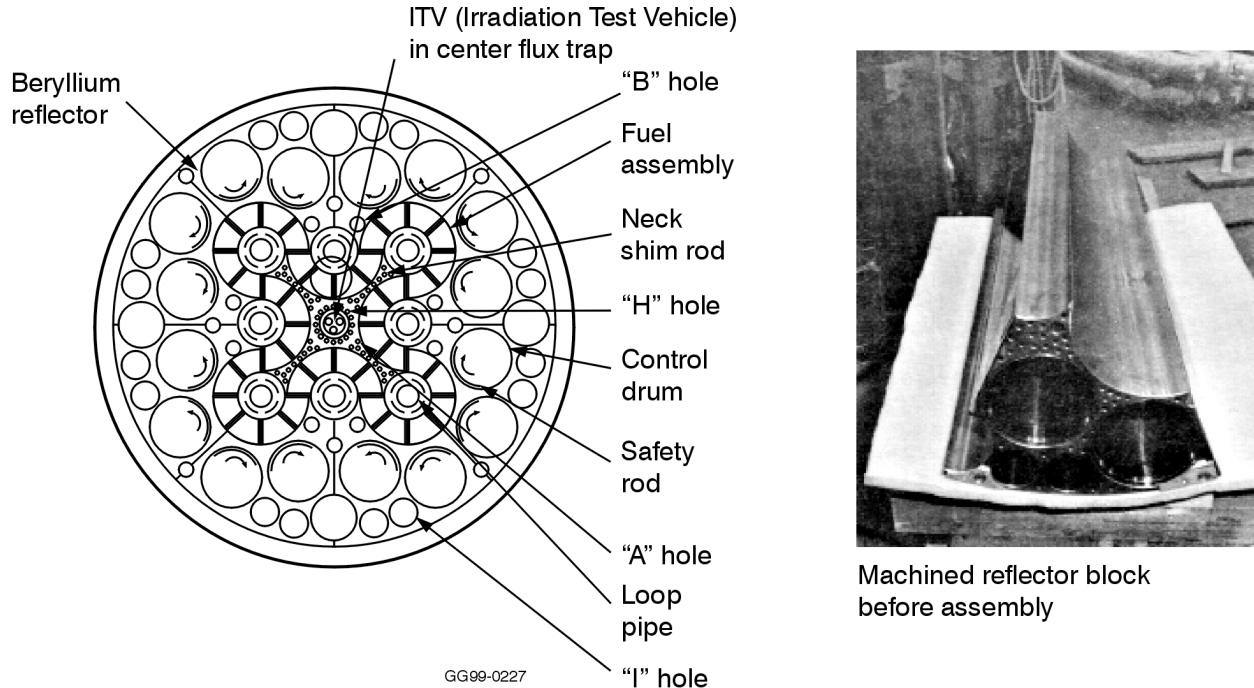

Fig. 4. ATR Reactor Core and Beryllium Reflector Block

By using purer beryllium metal (i.e., with less nitrogen), the concentrations of carbon-14 and other radionuclides can be significantly reduced. This is important for beryllium waste disposal planning. This P2 opportunity reduces personnel exposure, complexity of waste containerization and transportation, disposal system configurations, waste stream volume consumption, and magnitude of disposal site planning. This P2 opportunity can be used DOE complex wide in existing test reactors and future fission reactors to reduce nuclear waste and potentially eliminate beryllium as a greater-than-Class C waste stream.

Current procurement specifications for beryllium used for ATR reflector material does not limit the concentration of nitrogen. The nitrogen in beryllium transmutes to carbon-14 when irradiated and results in the major radionuclide impacting disposal. The  $^{14}\text{N} (n, p) ^{14}\text{C}$  reaction is the dominant  $^{14}\text{C}$  production mode in beryllium. Carbon-14 calculated inventories in beryllium are proportional to the nitrogen impurity in the beryllium. The current grades of beryllium specified (Brush Wellman S200F) has nitrogen concentrations ranging from 150 ppm to 350 ppm. Computer modeling conducted for the ATR reactor indicates that beryllium with nitrogen concentrations of 225 ppm or less will not result in greater-than-Class C material.

A beryllium grade (S65C) is available. Beryllium grade is more chemically pure, and its nitrogen concentrations range from 50 ppm to 200 ppm. If S65C beryllium was used in the ATR reactor, then it would not produce any beryllium material requiring greater-than-Class C disposal. Also, because S65C beryllium is more chemically pure, generation of other radionuclides is also reduced. S65C beryllium would also significantly reduce cobalt-60 gamma levels.

Pollution prevention funding was received in FY 1999 to conduct a preliminary assessment to evaluate substituting S65C for S200F beryllium in the ATR reactor. The preliminary assessment indicated that it was technically feasible and economically favorable. The preliminary assessment also indicated that S65C beryllium has superior mechanical properties and potentially could increase the beryllium service period in the reactor. The extended beryllium operating life in the reactor is a benefit because it would reduce the number of CICs required and result in reduced beryllium reflector material procurements and completely eliminate waste disposal of the unnecessary blocks.

As a result of the success of the preliminary feasibility study involving beryllium substitution and the basic understanding of lower nitrogen concentrations in beryllium to reduce radionuclide generation, a Four Phased Beryllium Disposition Plan was developed. This plan addresses the following:

- 12 legacy reflector blocks in canal storage
- 8 blocks currently in the reactor and to be removed in 2003
- Blocks being procured and manufactured today for 2003 CIC
- Blocks to be procured in the future to support the operating period of the ATR reactor.

During Phase 1A and 1B of the plan, physical beryllium samples will be collected and nitrogen will be analyzed on each of the 12 legacy blocks and on the 8 blocks removed from the reactor after the 2003 CIC. These phases provide data for improved characterization modeling specific for individual block waste stream determination. It is anticipated that 12 of the 20 blocks with the lowest beginning-of-life nitrogen concentrations will result in the disposal of some of the legacy low nitrogen and low reactor power lobe blocks as Class C remote-handled low-level waste.

Phase 2 collects physical beryllium samples for detailed carbon-14 measurements in the legacy blocks that are not disposed under Phase 1A and 1B. This phase allows more accurate characterization and will allow more blocks to be disposed of as Class C remote-handled low-level waste.

Phase 3 develops the strategy to smart load the beryllium reflector blocks in the ATR reactor at the 2003 CIC that are currently being manufactured from S200F beryllium. Using smart loading techniques for defining the specific reactor core lobe for installing the lowest nitrogen blocks in the highest power lobes will maximize the number of blocks that can be disposed of as Class C remote-handled low-level waste when removed from the reactor.

Phase 4 substitutes low nitrogen beryllium S65C for the current S200F and revises the ATR procurement specification to procure the low nitrogen beryllium for all future beryllium material used at ATR. Though all phases of the plan have pollution prevention aspects and benefits, Phase 4 reduces waste volume the most because of the long-term (50-year) future generation. Because S65C beryllium has a range of nitrogen concentrations, smart loading techniques developed in Phase 3 will be applied to Phase 4 loading of S65C beryllium material blocks at future ATR CICs. A comprehensive substitution assessment plan was developed to conduct the necessary studies to validate, certify, and approve the use of S65C beryllium. This plan was submitted to the INEEL Pollution Prevention Program for completion in Fiscal Year 2000.

Table I presents the anticipated beryllium block disposal results of implementing the 4 phases of the ATR Beryllium Disposition Plan. If the Disposition Plan is not implemented, all 76 beryllium blocks will require greater-than-Class C interim storage and disposal in a geological repository. When the plan is implemented over the operating life span of the ATR reactor, 69 of the 76 blocks will be disposed of as Class C remote-handled low-level waste, and only 7 blocks will require interim storage and disposal as greater-than-Class C in a geological repository.

Table I. ATR Beryllium Reflector Block Disposal

Plan Phase	Total Number of Blocks	Number of Blocks Addressed by Plan Phase	INEEL RWMC Disposed of as Remote-Handled LLW	INEEL GTCC Interim Storage	Off-INEEL Remote-Handled LLW Disposal	Off-INEEL GTCC Disposal at Geological Repository
Phase 1A	12	12	6	None	None	None
Phase 1B	8	8	6	2	None	2
Phase 2		6 from Phase 1A	3	3	None	3
Phase 3	8	8	None	2	6	2
Phase 4	48	48	None	None	48	None
<b>Total</b>	<b>76</b>	<b>76</b>	<b>15</b>	<b>7</b>	<b>54</b>	<b>7</b>

Tritium contained in the beryllium reflector blocks that are approved for INEEL disposal presents a special condition. This tritium must be managed to meet the disposal facility performance assessment requirements. Conceptual studies have identified several engineered alternatives, which are feasible for managing the tritium during the initial disposal period (120 years) at the INEEL RWMC. The economics of the alternatives will define the preferred option. Other tritium management options that would remove the tritium before disposal are being evaluated by EM Integration.

## CONCLUSION

Over the past few years, WNPD volume was successfully reduced by:

- Directing management attention to the initial inventory of INEEL WNPD
- Developing strategic objectives
- Developing and implementing specific work tasks consistent with the strategic objectives
- Focusing life-cycle planning on WNPD waste that continues to be generated.

Although only a few cubic meters have actually been disposed to LLW, nearly all previously identified WNPD has been assigned to a funded program and is included in a disposal plan. These wastes have a technical and regulatory path to disposal and will be disposed in a time frame consistent with the major waste types. The WNPD that remains in the active Current Database is a priority for future characterization. More detailed radionuclide characterization will provide information to make waste type determinations and further plan waste disposal. With the current knowledge of the INEEL WNPD inventory, more accurate and consistent interim storage can be planned for those waste streams that are greater-than-Class C and eventually require a geological repository disposal. The WNPD that has been disposed to other programs is reviewed annually to ensure that it continues to be included in the major waste stream management plan. In addition, INEEL potential generators are contacted annually to evaluate WNPD inventory changes.

The INEEL WNPD is well understood, and with continued planning and effective management, these waste streams will not become legacy waste remaining to be disposed during facility deactivation and decommissioning (D&D).

The ATR beryllium material has a life-cycle disposal plan that addresses legacy and future generated waste volumes. The plan provides for reducing radionuclide generation and shifts beryllium waste from the more difficult and unavailable greater-than-Class C disposal to the currently available Class C remote-handle waste disposal. The plan has a significant pollution prevention element, which the INEEL Pollution Prevention Program supports. Class C remote-handled LLW currently has a disposal path at the INEEL RWMC and at other off-INEEL disposal facilities. The volume of beryllium greater-than-Class C waste requiring interim storage and geological repository has been significantly reduced. A potential exists to extend the operating life of beryllium material in the reactor, which will reduce procurement cost and disposal volume and cost. Disposing of beryllium materials will require special engineered disposal systems to manage the tritium in the waste until it decays to safe levels. However, tritium management will be required regardless of the final waste stream disposal path the beryllium follows.

Work Supported by  
U.S. Department of Energy  
Assistant Secretary Environmental Management  
Under DOE Idaho Operations Office  
Contract DE-AC07-99ID13727