

TRANSPARENCY DEMONSTRATION OF UNDERGROUND RADIATION AND ENVIRONMENTAL MONITORING

*Barry Schoeneman, Sandia National Laboratories;
Dennis Hofer, Westinghouse Waste Isolation Division*

ABSTRACT

One of the legacies of the nuclear weapon and nuclear power cycles has been the generation of large quantities of nuclear waste and fissile materials. As citizens of this planet, it is our responsibility to provide for safe, secure, transparent, disposal of these waste nuclear materials. The Sandia Cooperative Monitoring Center sponsored a Transparency Monitoring Workshop where the use of the Waste Isolation Pilot Plant (WIPP) was identified as a possible transparency demonstration test bed. Three experiments were conceived as jumpstart activities to showcase the effective use of the WIPP infrastructure as a Transparency Demonstration Test Bed. The three experiments were successfully completed and demonstrated at the International Atomic Energy Association sponsored International Conference on Geological Repositories held in Denver Colorado November 1999. The design and coordination of these efforts is the subject of this paper. In conclusion, with good supportive team effort among DOE contractors, the WIPP infrastructure can be used as test bed for transparency technology development. This will be accomplished without interfering with the waste emplacement process at an operating WIPP. Each experiment was a success and demonstrated several technologies that can be applied to an underground deep geological repository. The jumpstart activities successfully supported an international conference on geologic repositories, which was a high priority initiative for the Department of Energy. The development of the Center for Applied Research and Underground Science (CARUS) in Carlsbad will establish WIPP as an international test bed for waste storage transparency monitoring technologies.

INTRODUCTION

“Transparency is defined as a cooperative process of providing information about disposition systems to outside parties so that they can independently assess the safety, security, and legitimate management of nuclear materials.”(1)

The Jumpstart Transparency experiments were proposed as a result of initiatives identified at the Sandia Cooperative Monitoring Center (CMC) sponsored Transparency Monitoring Workshop held February 1999. A team of Sandia National Laboratories, Los Alamos National Laboratories, and Westinghouse Electric Company personnel coordinated this project. The project was funded through the Carlsbad Area Office of the Department of Energy. The team met for the first time in May 1999. The goal established at this meeting was to develop an effective demonstration of transparency technology for the International Atomic Energy Agency (IAEA) sponsored International Conference on Geological Repositories held in Denver Colorado November 1999. The effective proof-of-concept demonstration experiments would include near real-time Web demonstrations of monitoring selected WIPP environmental parameters and of a WIPP waste-drum demonstration stack. This was accomplished using established transparency technologies and the existing WIPP monitoring processes.

LIST OF ACRONYMS

- WIPP Waste Isolation Pilot Plant
- CMC Cooperative Monitoring Center (Sandia National Laboratories)
- CARUS Center for Applied Research and Underground Sciences
- NTvision Video capture and processing system operating under WindowsNT®
- CMC Cooperative Monitoring Center
- CMS Central Monitoring System
- LPU Local Processing Unit
- OMI Operator Machine Interface
- MMS Material Monitoring System

WM'00 Conference, February 27 – March 2, 2000, Tucson, AZ

- DCC Data Collection Component of MMS
- DSC Data Storage Component of MMS
- IAEA International Atomic Energy Association
- CUI Custom User Interface
- FO Fiber Optic
- WID Waste Isolation Division (of Westinghouse Corporation)
- SNL Sandia National Laboratories
- DOE Department of Energy
- CAO Carlsbad Area Office
- EM DOE Office of Environmental Management
- NN DOE Office of Nuclear Non-proliferation
- CAM Continuous Air Monitor
- U/G Underground
- CCD Charge Coupled Device for imaging
- CMR Central Monitoring Room
- RFTID Radio Frequency Tamper-Indicating Device (container seal)
- T-1 ESP RFTID Electronic Sensor Platform
- RS-232 Recommended Standard for digital serial communications
- RS-170 Recommended Standard for B/W video signal in the US

PURPOSE

The purpose of the demonstration was to provide several proof-of-concept experiments that would showcase the effective use of the Waste Isolation Pilot Plant (WIPP) infrastructure as a transparency demonstration test bed. These transparency monitoring experiments apply current technology to the geologic repository setting to demonstrate the technology used to monitor nuclear materials in storage facilities in the back end of the waste cycle. Additionally, with the short time frame for the project, the team demonstrated how a cooperative team of DOE contractors could work together to provide a successful demonstration for the Denver conference.

DEMONSTRATION SYSTEM DESIGN

The Transparency Demonstration Monitoring System collects and stores radiation and environmental data from the WIPP Site. This data is provided near real-time, in an intuitive format, to the Internet for viewing at remote locations. This concept is depicted in Figure 1.

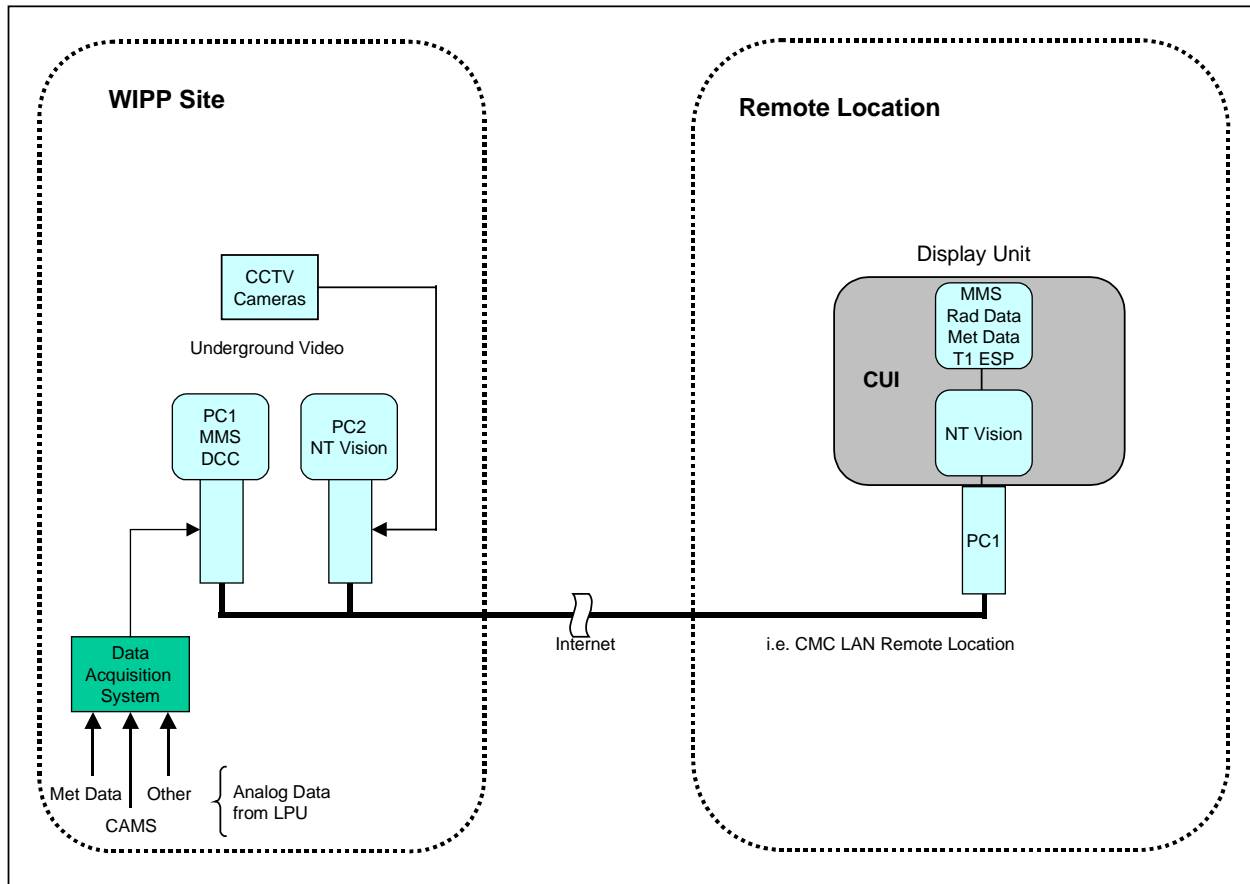

Figure 1 - Conceptual System Block Diagram

The demonstration monitoring system was designed to gather a variety of data from the WIPP Site. Figure 2 shows the detailed block diagram of the system implementation. Data was gathered from monitoring points above ground and underground. The kinds of data gathered were meteorological and underground environmental data, video monitoring data, and data from material-containment seals. Data signals were of varied types, such as analog, digital and video. The meteorological and environmental data was available to the system as current loop, 4 – 20ma and was provided by the site's Central Monitoring System (CMS), for data management, through a local processing unit (LPU). Table 1 lists these data points. Video was RS-170 from charge-coupled device (CCD) black and white cameras and the radio frequency tamper-indicating-device (RFTID) seal monitoring data was RS-232 serial data from the T-1 electronic sensor platform (ESP). The T-1 ESP is depicted in Figure 3. The video and RS-232 data was transmitted to and from the underground by fiber optic multiplexers.

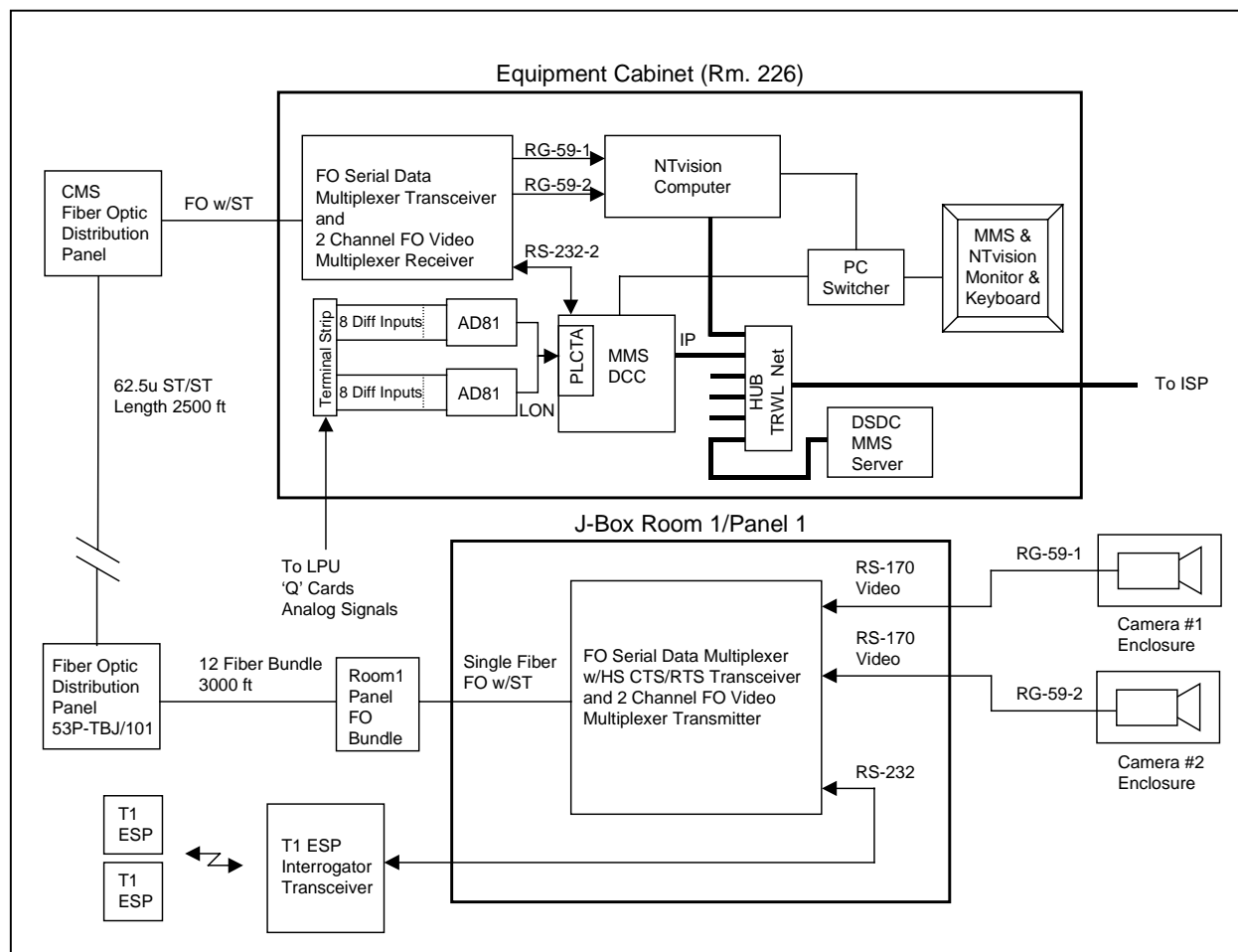

Figure 2 - Detailed Block Diagram of the Transparency Demonstration Monitoring System

| Description | Dynamic Range | Units |
|---|----------------|--------|
| U/G CAM Alpha Radiation Level | 1 to 999293.5 | CPM |
| U/G Alpha CAM Air Flow | 0 to 3 | SCFM |
| U/G CAM Beta Radiation Level | 1 to 1245201 | CPM |
| U/G Beta CAM Air Flow | 0 to 3 | SCFM |
| U/G Exhaust Shaft Weather Station Temperature | -27.4 to 118.4 | DEG F |
| U/G Exhaust Shaft Weather Station Relative Humidity | 0 to 100 | RH PCT |
| U/G Exhaust Shaft Weather Station Pressure | 23.62 to 31.30 | IN HG |
| Surface Wind Speed at 10 meters | 0 to 50 | M/S |
| Surface Wind Direction at 10 meters | 0 to 360 | DEG |
| Surface Air Temperature at 10 meters | -30 to 50 | DEG C |
| Surface Relative Humidity at 2 meters | 0 to 100 | RH PCT |
| Surface Barometric Pressure at 2 meters | 600 to 1100 | MB |
| Surface Precipitation | 0 to 25.4 | MM |
| Total Underground Air Flow | 0 to 600 | KCFM |

Table 1 - Data Monitored on the Westinghouse Central Monitoring System (CMS)



Figure 3 T-1 Electronic Sensor Platform with Fiber Optic Seal

The monitoring system is comprised of two subsystems for the transparency demonstration. A video data collection system and a system that collects all of the other data types (e.g., meteorological and radiation data.) Fundamentally, the monitoring system is designed to collect, format, store, and present data to the user(s) over the Internet.

The video collection system is based upon NTvision software developed by Los Alamos National Laboratory. For the demonstration, two cameras, located underground and viewing simulated waste, were monitored by NTvision. NTvision continuously evaluates captured video images of the scene(s) for changes in content. When the image content changes above programmed thresholds, a series of images are stored forming a movie of the event(s) that caused the changes. Additional video information is also available about the video event. This information consists of four images. The images are, the existing reference image (established before the event), the image that caused the event, the difference image (difference between the reference and the event image), and the new reference image. Examples of these images are shown in Figure 4. NTvision updates the reference images at regular programmable intervals.



Figure 4 Image Information Provide by NTvision Resulting from an Event

The second subsystem collects data from all of the other monitored sources. This collection system is based upon the Material Monitoring System (MMS) developed by Sandia National Laboratories. The MMS has three primary components, the Data Collection Component (DCC), the Data Storage Component (DSC) and the Custom User Interface (CUI). These three components communicate over standard Ethernet connections and the Internet.

The DCC interfaces to the variety of data sources monitored for the transparency demonstration system. Software drivers and hardware interfaces residing on the DCC allow the MMS to collect data from virtually any data source. The DCC collects the data, converts it to a common message exchange format, and sends it to the DSC, in TCP/IP protocol, for storage.

The DSC stores the data provided by the DCC. It also supports the standard MMS Web pages for the presentation of the collected data on the Internet. The standard Web pages were not used during the International Conference on Geologic Repositories in November 1999. MS SQL Server 7 is the database used by the DSC for data storage and access.

For the purposes of the transparency demonstration, a custom user interface (CUI) was developed as an interpretive near real-time graphical data display in place of the standard MMS browser pages. This display is shown in Figure 3. The CUI was running on a remote terminal at the conference. It was updated at frequent intervals with current data from the DSC. The CUI data was updated approximately every minute over the Internet. The graphical display consisted of a series of analog gauges with indicators that represent the relative level of each data point being monitored. The minimum and maximum values of each gauge represent the full dynamic range of the data signal.

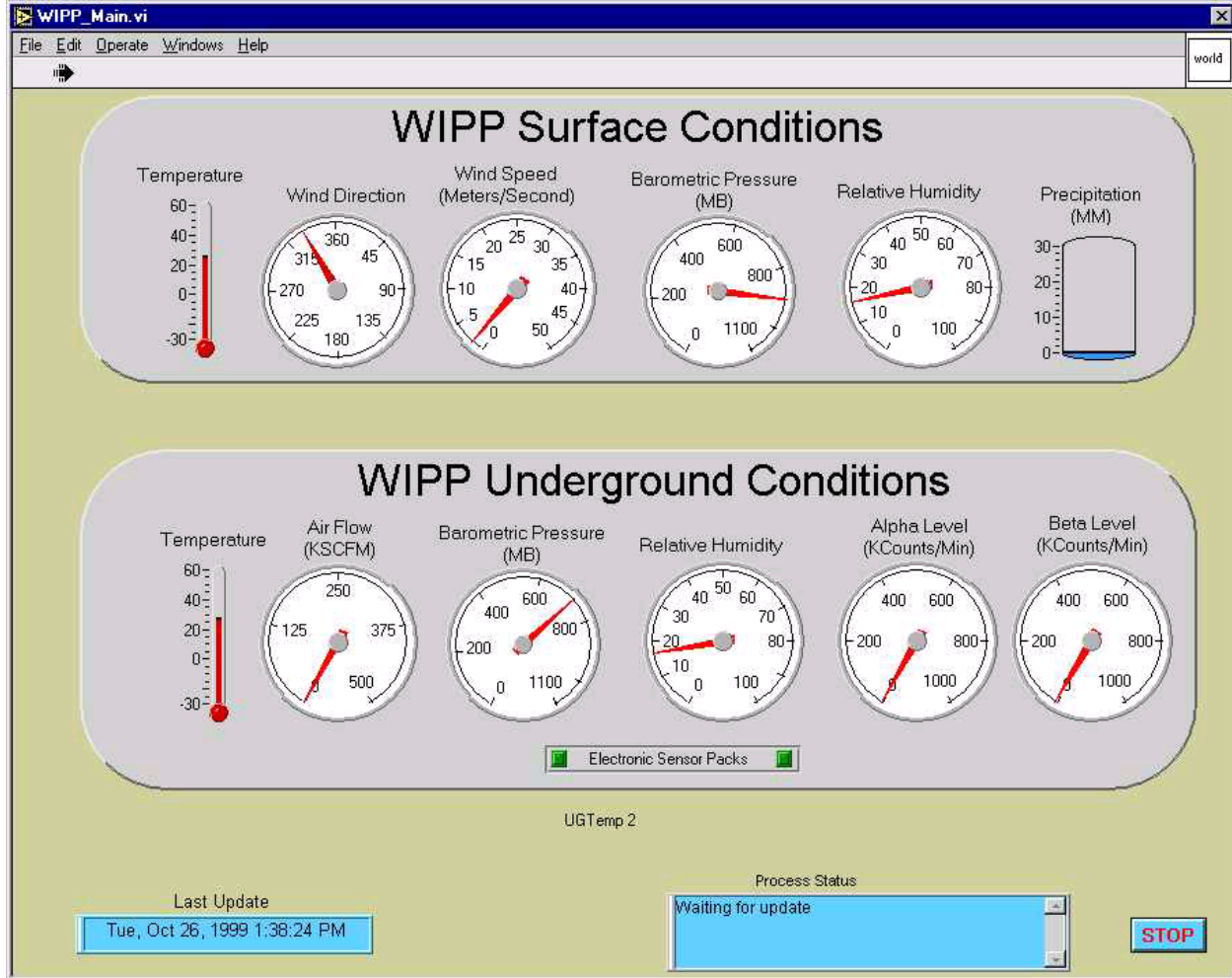

Figure 5 - Monitoring System Custom User Interface (CUI) Example

DEMONSTRATION SYSTEM IMPLEMENTATION AND FIELD INSTALLATION

Located in room one of panel one, the WIPP maintains a stack of 55 gallon waste drums which are sand filled and configured in a seven pack arrangement for waste handling operator training. This simulated waste provided a convenient arrangement to test the transparency technologies. These waste drums were outfitted with two T1 ESP units providing data to the MMS database. Video cameras were attached to the rib in room one at a distance of 40 feet and 90 feet to capture video frames of the waste stack from two different perspectives.

The equipment rack which contains the MMS database, signal interface modules, the DCC, and DSC was installed in room 226 on the second floor the Support Building. This location was chosen to take advantage of an existing LPU for ready connection to the CMS. It was also conveniently collocated with the WIPPNet computer room providing ready access to Internet telecommunications equipment. The installation was conducted within the work control requirements of the operating WIPP. An engineering drawing package and work installation instructions was developed and the equipment is identified on the WIPP component indices and engineering drawings.

The installation took advantage of the existing underground fiber optic infrastructure and added 100 meters to the link to complete a 1523 meter connection for the multiplexed data signal. Six strands of fiber were installed. These fibers had a power loss across the length of 2.7dB minimum and 4.4dB maximum loss at a wavelength of 1350nm. Two video signals and digital data from the two T1 ESP units was multiplexed to provide a single data stream from the WIPP underground to the equipment rack located on the second floor of the WIPP Support Building.

WM'00 Conference, February 27 – March 2, 2000, Tucson, AZ

Support for this demonstration project was outstanding from all participants. It was essential that each planned element of the design, the procurement process, the installation engineering, and the system checkout be conducted on a tight schedule to meet the deadline to provide a successful demonstration for the IAEA Geologic Repository conference in November 1999. A team of Sandia National Laboratories, Los Alamos National Laboratories, and Westinghouse Waste Isolation Division DOE contractors and sub-contractors coordinated this project. Close coordination was required between the Sandia National Laboratories design engineer and the Westinghouse Electric Company design engineer to coordinate the installation because equipment was assembled in Albuquerque, New Mexico and installed in Carlsbad, New Mexico. Extensive use of current communications technologies such as e-mail, voice mail, and video conferencing expedited the processes and saved the project money as well.

CONCLUSIONS

Transparency and the supporting technologies were successfully demonstrated at the International Conference on Geologic Repositories held in Denver Colorado November 1999 on a limited scale. This transparency concept provided information from the WIPP to the conference in a manner that was interpretive, intuitive, credible and valuable. To reach the ultimate goal of transparency, additional studies and development will be required to understand how information should be presented to the end user (public).

The WIPP is currently establishing itself as a test bed for nuclear material transparency technology. The CARUS (Center for Applied Research and Underground Sciences) recently established in Carlsbad, NM, will support the test bed. Transparency is an active project at the CARUS. This project is expected to have a web site, providing near real-time data and historical information, for transparency.

REFERENCES

1. "Using the Waste Isolation Pilot Plant (WIPP) as a Test Bed for Waste Storage Transparency Monitoring Technologies", Report to Congress, Department of Energy, Sandia National Laboratories, Westinghouse Isolation Division