

**THE EVOLUTION IN THE LL AND IL RADIOACTIVE WASTE MANAGEMENT
IN FRANCE AND ITS IMPACT IN THE ANDRA'S ACCEPTANCE CRITERIA
AT THE CENTRE DE L'AUBE DISPOSAL FACILITY**

Claudine Bouchet, Gérard Cédon, Bernard Félix, Guy Langlois
ANDRA
Agence Nationale pour la gestion des Déchets Radioactifs
1 - 7 rue Jean Monnet 92298 Chatenay – Malabry Cedex
France

ABSTRACT

The design and the operating methods of the Aube centre disposal site resulted from the experience of the first French disposal of intermediate level (IL) and low level (LL) radioactive waste in the centre de La Manche. The Basic Safety Rules, issued by the regulatory / licensing authorities as the waste acceptance specifications from ANDRA : the French national agency for radioactive management, benefited from it. The ANDRA's Centre de l'Aube received a provisional license and its technical prescriptions in 1992, and since, has been operated on this basis.

In 1996, ANDRA related five years of operation and monitoring as well as the centre de l'Aube safety analysis in a "final safety assessment report". Regulatory / licensing authorities have processed these data, have required a re-appraisal of internal procedures and of the acceptance specifications of the waste packages, and finally have definitively licensed the centre de l'Aube, in September, 1999, to operate according to new licensing requirements.

The ANDRA specifications for waste package acceptance at the centre de l'Aube disposal are to be improved by a better consistency between the safety calculation parameters and the specified parameters. They have to take into account the waste production evolution in particular the larger amount of incinerated waste and cast metallic waste and equally the interest of the producers in the standardization of the waste package manufacturing.

The ANDRA waste tracking system is bettered by including the characterisation of its toxic chemical components, by extending the set of registered long-lived radionuclides and by paying attention to the uncertainty of the activity determination. A unique computer system will be implemented to verify the admittance criteria, to track each waste package from the manufacture to the disposal, to manage the centre de l'Aube operation and to inventory waste package location and total activity in the different vaults and in the disposal site.

**THE RESPECTIVE TASKS OF THE WASTE PRODUCERS AND OF ANDRA IN
THE LL AND IL RADIOACTIVE WASTE MANAGEMENT IN FRANCE,**

**Technical and regulatory framework for the development of the radioactive waste
disposals,**

From its origin in 1979, ANDRA the French national agency for radioactive management, is in charge of the final disposal of the intermediate and low level waste generated by the French nuclear research centres and by the nuclear industry.

WM'00 Conference, February 27-March 2, 2000, Tucson, AZ

The French law issued in December 30, 1991 has officially enlarged the responsibility of ANDRA. This law created ANDRA as an independent public service company entrusted not only with the management of the existing long term disposal sites but also, with the design, set-up and construction of new disposal facilities.

The agency has to participate in the definition of, and contribute to the research programmes induced by the long-term management of radioactive waste including specially, high level and long lived radioactive waste. In this purpose, the agency is responsible for the realization of two underground laboratories. It has also to issue, in accordance with the basic safety rules, the specifications for the conditioning and the disposal of this waste. Concerning radioactive waste accumulated by the emerging nuclear industry (radium industry) and the miscellaneous nuclear sector, which includes chemical (phosphate, thorium, rare earth,) and metallurgical industry (zirconium,), ANDRA has to register the location and the present state of these wastes all over the French territory.

In France, the management of the IL and LL radioactive waste received first, and a long time ago, a technical and regulatory framework. The operation at the La Manche surface disposal, the waste package manufacturing and their management, which have been initiated in 1969 under the guidance of the French Atomic Energy Commission (CEA, Commissariat à l'Energie Atomique), have been ruled by the French regulatory / licensing authority : the Directorate for Safety of nuclear installations (DSIN, Direction de la Sûreté des Installations Nucléaires). This Directorate finally issued in 1982 – 1984, the Basic Safety Rules : RFS.I.2 and RFS.III.2.e (Règles Fondamentales de Sûreté I.2 et III.2.e).

On the basis of the requirements applied at the La Manche disposal facility, ANDRA has specified its requirements for waste package conditioning, and for the acceptance procedure, in 1985. The specifications define separately, the general conditions which all the waste packages have to comply with, and the different requirements for particular waste form and packaging. They have been reviewed in 1991-1992, to take into account the licensing requirements of the regulatory / licensing authorities that complemented the governmental decree creating the Aube disposal.

The thirty years of industrial experience in the management of the IL and LL radioactive waste, have resulted in technical and regulatory documents which will influence, and hopefully will facilitate the development in France of new management systems for the other types of radioactive waste.

Specifications and manufacturing of the waste packages :

Presently, the ANDRA waste acceptance criteria offer waste producers, several technical solutions leading to the final disposal of their IL and LL radioactive waste.

In any case, the producer has to manufacture waste packages which comply with the general conditions specified in two specifications STG 1.1.A (Spécification Technique générale 1.1A) and STP 1.1.1.A. (Spécification Technique Particulière 1.1.1.A) concerning respectively the waste form, (their physical and chemical properties), and their radioactive characteristics. Exceptionally, ANDRA substitutes for producers, such as hospitals, miscellaneous industry and laboratories, that do not have their own conditioning facility.

WM'00 Conference, February 27-March 2, 2000, Tucson, AZ

The waste packages may be designed for a direct placement in the disposal vaults or for processing in the centre de l'Aube facilities prior to placement.

If the first option is adopted, the producer can choose current containers that do not comply with the ANDRA durability requirements, standardized metallic drums or metallic boxes. In this case, the waste packages are disposed in vaults, which are grouted before closure. The producer can also choose a container exhibiting durability, practically a concrete container fulfilling corresponding requirements, and therefore the waste packages will be disposed in a vault simply back-filled with gravel.

The volume of the waste packages designed for a direct placement in the disposal vaults can range from 200 liters, to 10 cubic meters, and their mass is accepted up to 32 metric tons. Various types of handling tools are available at the Aube centre that fit 15 different types of waste packages.

Some waste generators prefer to simplify the waste conditioning. Small and compressible waste are put in 200 liters drums for shipping to the centre de l'Aube, where after compaction by a press with a 10,000 kN capacity, they are immobilized in 450 liters drums by a hydraulic binding. Large and rather rigid waste can be put in 5 or 10 cubic meters metallic boxes, which are shipped to centre de l'Aube and there grouted, in a fully automated grouting facility. Therefore the centre de l'Aube is a waste package producer and is submitted to the same rules summarized hereafter, as the other producers for admittance to the disposal.

Waste package certification and quality assurance of the production,

The waste producer initiates the waste acceptance process. In co-ordination with ANDRA he has to document several files. One describes the waste origin, their characteristics and the waste package manufacturing. Another one indicates the equipment and the methods involved in the determination of the radioactive parameter, and a third one provides the test or calculation results which evidence the compliance of the waste package with the ANDRA specified requirements. The waste producer has to implement a quality assurance programme that is focused on the control of pre-established parameters, which are critical for quality.

ANDRA issues acceptance certificates. Since 1985, the three major French waste producers: CEA, Electricité de France and COGEMA have been issued 83 of them and ANDRA itself, 7.

Prior to waste shipment to the Aube centre, the waste producers have to report through a computerized tracking system, the physical and radioactive characteristics of each waste package, which is identified by a label indicating its computer code. These data are verified and followed along the movement to the disposal unit.

Due to the fact that the waste producers ensure the quality of the waste packages in France, the quality control by ANDRA is based on inspections of the waste producer's facility.

Special attention is paid to primary waste sorting and its traceability. The quality assurance organization of the waste producer is audited. The quality control by ANDRA involves the computerized tracking system as well, which verify the conformity of the reporting provided by the waste package producer, to the corresponding acceptance criteria and to the data of the acceptance files.

Nevertheless ANDRA samples from 200 to 300 waste packages, each year, for a non-destructive measurement of its radioactive and physical characteristics and from 15 to 20 waste packages for a destructive appraisal, which are realised in sub-contractors facilities.

THE DEFINITIVE LICENSE TO OPERATE THE CENTRE DE L'AUBE DISPOSAL,

The licensing of the centre de l'Aube disposal and the licensing requirements

According to the French nuclear safety rules, operation at the centre de l'Aube disposal facility which is considered as a basic nuclear installation (INB, installation nucléaire de base) is allowed through a governmental decree. At the very beginning of operation, a basic nuclear site receives a temporary license. The centre de l'Aube received it on January 16, 1992, providing that the licensing requirements are followed. Additionally, ANDRA has to issue a so-called "final safety assessment report" within five years, i.e. before 1997. This report relates the results of the radiological monitoring of the disposal and of its environment. It presents safety calculations, which simulate pollutant impacts in normal and accidental scenarios, as well as the incidental events occurred in the disposal operation and the improvements implemented.

In 1997 - 1998, the "final safety assessment report", has been investigated by the regulatory / licensing authorities. It resulted in complementary analysis and in modifications of the centre de l'Aube procedures. That required the reviewing of the ANDRA "general rules of operation" and of its "internal emergency plan". Subsequently, a definitive license to operate was granted to ANDRA on September 2, 1999, in accordance with new licensing requirements divided into four sets of requirements :

- (1) The first set addresses the disposal of the waste. It describes the physical and chemical properties of the waste form, as well as the packaging performance, which are to be met. For practical application of these requirements the technical prescriptions refer to the waste package acceptance specifications that ANDRA is ordered to review. It defines objectives for the disposal safety in general terms rather than through quantified limitations. Noticeable exceptions are the total radiological capacity of the centre de l'Aube disposal attributed to different radionuclides, and of the relevant maximum activity of these radionuclides per unit weight of the packages, and of the vault after closure.

Table 1 provides the radiological capacity of the centre de l'Aube allowed in the licensing requirements issued in 1992 and those allowed in the 1999 issue. The number of radionuclides is enlarged to take into account long-lived radionuclides (mainly pure beta emitters) because of their long-term dose impact that has been evidenced as possibly significant. Radiological capacity for some of them has been re-assessed taking into account the latest information on future waste production (decommissioning, retrieving from interim storage).

- (2) In the licensing requirements, the second set of requirements is concerned with the operation in the disposal and in the storage and conditioning facilities.
- (3) The third set is related to the records of information about the disposal management.
- (4) The fourth set provides guidance for the monitoring of the disposal and of its environment.

Any discrepancy from these requirements has to be reported to the Directorate for Safety of nuclear installations, DSIN.

The review of the ANDRA's specifications for the waste package acceptance and its relation with the safety assessment of the centre de l'Aube disposal,

ANDRA is presently working on modifications in the waste package acceptance specifications. The first reason is to benefit from the seven-year experience of the centre de l'Aube operation. The second one is to comply with the licensing requirements issued in 1999 and finally to improve the consistency of the technical specifications with the hypothesis of the final safety assessment issued in 1996.

The waste package acceptance procedure is complemented. ANDRA and the waste producers agree to define a set of technical parameters relevant to the waste package characteristics and to their manufacturing process. These parameters are chosen because they can be monitored in current production and because they are related to the compliance of the waste packages with the specified requirements. This compliance has to be demonstrated in the producer files. The measurements of this set of parameters will prove the conformity of the waste package with the producer standards, or will evidence the reason why it is not. The quality assurance programme makes reference to a control of these parameters.

Specifications applied to all type of waste packages,

The ANDRA specifications about the activity characteristics have been moved. The radionuclides which could eventually be contained in the waste because of their half-life, have been identified. They are 143. The waste producer has to list, in his acceptance files, which of these radionuclides, may have a specific activity over an indicated threshold value. For each of these listed radionuclides, an activity value will be declared for each waste packages, even if this value is zero.

For safety reasons, the activity declarations of the waste producer are based on assumptions which generally overvalue the activity obtained by direct measurements, as it has been evidenced by ANDRA, through gamma spectrometry. In the acceptance file the waste producers will relate their declared activity with their best estimate of this activity. So doing they will provide their uncertainty in the evaluation of activity values.

A list of toxic species has been set up, which eventually may represent a risk for the environment: mercury, lead, cadmium etc. The waste producer has to inventory in his acceptance files, the average amount of these species, which will be brought, by their waste packages. The same requirement is introduced for species, which may damage the confining barriers such as sulphate, or ammonium or which may boost the radionuclide migration.

Specifications applied to particular waste packages,

Homogeneous waste such as sludge, resins, concentrates, the specific activity of which exceeds the embedding threshold as defined by the ANDRA specifications, are not necessarily conditioned in a leach resistant matrix. A confining envelope or a container with confining properties may be accepted as a convenient solution, provided that the waste is immobilized in a mechanically resistant matrix.

The reviewed specifications separate the waste package to be disposed in grouted vaults, with non durable container, from the waste package to be disposed in back-filled vaults with long-duration concrete container.

In the calculations initiated in the “final safety assessment report”, the waste packages were divided into four classes corresponding to a given model. Two classes are assigned to waste packages with long-duration concrete containers and two others to waste packages with non-durable containers. Figure 1 represents the correspondence between the four models and the different structures of the waste packages specified by ANDRA.

High confining performances are attributed to two classes, because the confining parameters of all the waste packages, which belong to these classes, are specified. It is a consequence of the high specific activity of these packages, which exceeds the embedding threshold of at least one radionuclide, as defined in the ANDRA specifications. For the two others, the confining parameters are not specified. The value introduced in the model is deduced from measurements or is correlated to the mechanical resistance of the immobilisation matrix.

Practically, the class of waste packages with long-term durability container, and specified confining performance is the most complex of all. ANDRA takes into account the contribution of the durable container to the radionuclide confinement, in its safety calculations even if its diffusion coefficient is not specified. The overall confinement performance of the waste package may be provided by the embedding matrix of an homogeneous waste, by the internal envelope (the grouted layer surrounding the immobilized waste) or by the container. According to the ANDRA specifications, the container has to comply with requirements, which depend on its thickness and on the confining performances of the embedding layer, or of the matrix.

Because the waste producers are greatly interested in the standardization of the waste conditioning and packaging, ANDRA has specified a waste package belonging to the fourth class, for which the confining requirements are met exclusively by the container. Therefore the requirement for the waste matrix is less demanding because the matrix has only to immobilize the waste and to prevent it from damaging the container by swelling or by chemical attack. Requirements for the container material are numerous, addressing water to cement ratio, cement and silica fume content, gravel and sand characteristics but also mechanical and confining parameters: hydraulic conductivity, tritium diffusion coefficient etc. as well as shrinkage coefficient. The tightness of the container closing is specified, and very limited cracks are acceptable.

THE WASTE PRODUCTION EVOLUTION AND THE PRODUCER'S NEEDS,

The decommissioning of nuclear facilities and the ANDRA very low level radioactive waste disposal and graphite waste disposal projects,

The decommissioning of nuclear industrial and laboratory facilities will generate during the next two decades, an important quantity of demolition products, the specific activity of which will be generally lower than 100 MBq per metric ton.

French regulatory / licensing authorities have decided not to define a clearance level under which a VLL radioactive waste can be managed as a non radioactive one. As a consequence, any waste from a basic nuclear installation (INB installation nucléaire de base) will be

directed towards a radioactive waste disposal. This policy brings about the possibility for a specific monitoring of the disposal, and dissuades from diluting radioactive waste by mixing it with non-radioactive ones. The feasibility of this type of waste disposal has been achieved and acceptance specifications have been elaborated. The setting up is under investigation by ANDRA and the consultation with the representatives of the local communities is on-going.

A small part of the decommissioning waste has a specific activity of intermediate and low level, but some of them are not allowed to be disposed at the centre de l'Aube because of the activity of the long-lived radionuclides. This is the case for a part of graphite waste from the gas-cooled reactors dismantling: graphite sleeves or piles with non-acceptable ^{36}Cl and ^{14}C activity levels. A surface disposal for this long-lived low level radioactive waste appears to be feasible. The long-term confinement could be ensured by the disposal, provided a sub-surface placement in a clayey geological formation.

Development of technical solutions for the disposal at the centre de l'Aube of non-standard IL and LL waste packages,

As seen before, the ANDRA specification for the acceptance of waste packages offer the waste producers, various conditioning solutions and moreover, specific solutions for non standard waste can be implemented which require impact evaluation and a safety report submitted to the French Directorate for safety of nuclear installations, DSIN.

For example, ion exchange resins from COGEMA, could be conditioned in a cement matrix in a drum, placed in a concrete container but the dose rate at the package surface could have been above the specified limit of 2 mGy/h, unless a thick lead screen was implemented for shielding. To reduce the quantity of toxic metal disposed at the Aube centre, steel has been preferred to lead, therefore the dose rate limit was not reduced sufficiently and specific handling devices and procedures have been implemented.

Because of its preventive maintenance program, EDF has on the agenda, the retrieving of large elements from his nuclear power plants, such as vessel closure heads or racks in cooling pools for fuel assembly. In each case, a solution has been studied for the disposal in specific engineered structures of the centre de l'Aube disposal.

The implementation of a new incineration and melting facility for LL radioactive waste,

In the recent past, the radioactive waste producers have achieved important efforts to reduce the volume of the waste production. For instance, the EDF output has been reduced to half its value, within 12 years. This effort is on-going. A new facility called CENTRACO (nuclear centre for treatment and conditioning of radioactive waste) has been implemented by SOCODEI a subsidiary company of EdF and COGEMA in Codolet near Marcoule in the Southeast of France. It is designed to incinerate 5,000 metric tons of solid and liquid waste coming from maintenance operations including paper, plastic, clothes, water filters, resins, oils, solvents etc.

This facility is also equipped with an induction furnace to melt as much as 1,500 metric tons of radioactive scrap iron and various metallic waste.

ANDRA has been consulted for the conditioning and the packaging of the ultimate waste. Four acceptance certificates have been attributed to SOCODEI. Figure 1 shows a picture of

one of the accepted waste package; it is a cast steel ingot with a geometry and a handling tip, which are different from the specified ones. The waste package for the incineration ashes is composed of recycled iron drum in which the waste immobilization is obtained by cementation.

THE TRACEABILITY OF THE WASTE AND OF THE WASTE PACKAGES,

ANDRA is responsible for the preservation of a data bank of the waste package disposed at the centre de l'Aube. This data bank contains for each package, the physical and radiological characteristics of each package as they are provided by its producer and checked before admittance, and their location in the vaults of the disposal.

From the beginning, the data bank is composed of individual waste package files which are initiated by the generator of the waste and complemented at the facility, where the waste is conditioned and packaged. These files are generally paper ones, but the waste producers (p.g.. EDF), has developed at a national scale, a computer system called DRA.

The waste producer has to guarantee the validity of the data, with the support of documents available for an examination by ANDRA. All these data and documents are to be archived by the producers under the guidance of ANDRA.

As early as 1983, ANDRA had implemented a computerized tracking system, for the management of the waste packages admitted at the Manche disposal facility. This system tracks the waste package from its manufacturing to its final disposal. The computer system links ANDRA headquarter, to the waste producer headquarters, to their facilities and to the centre de l'Aube disposal. At the final stage the waste packages are disposed according to a predefined cartography. The placement co-ordinates are recorded and transferred to the computerised tracking system.

The tracking system simplifies the management of the packages, which are compacted at the facility, because it suppresses the tedious manipulation of data for ensuring the consistency between the final package and the primary compacted packages.

The tracking system follows the cumulative activity of the different radionuclides disposed in each vault. It indicates that the maximum total activity allowed by the technical prescriptions in a single vault is not overstepped. Figure 3 shows, for 11 radionuclides or group of radionuclides, that the percentage of these maximum values, at its closure, is sometimes very low. The values met in the vault E01R02, allow waste management which complies with the radiological capacity of the disposal site.

For management convenience, the total volume of the disposed waste packages is regularly compared with the total activity of the radionuclides listed on Table 1, for which a maximum radiological capacity has been allocated in the licensing requirements.

On figure 4, are drawn the evolutions, over a period of 5 years, of the total waste package volume represented by the percentage of the disposal capacity, in relation with the total activity of the alpha emitters, of ^{94}Nb and of ^{36}Cl represented by the percentage of the corresponding radiological capacity. Because of their low radiological capacity, the management of waste packages with alpha emitters is the more stringent

The inventory of the total activity of the waste is an input data for the safety calculations. In 1995, the inventory of the total activity which will be disposed at the closure of the centre de l'Aube has been estimated using the data of the computerized tracking system and the producer expectations. For the first time, it took into account the future production of new type of waste specially induced by the nuclear facility decommissioning and it re-estimated the activity of the long-lived radionuclides contained in already disposed packages. This re-estimation was possible because waste sampling had been performed either by waste generators or by ANDRA, and radiochemical analysis have led to the determination of average ratio relating their activity to that of gamma emitters tracers, ^{60}Co and ^{137}Cs .

ANDRA has planned the development of a new computerized system for the waste package management that will substitute for both the present tracking system and the centre de l'Aube computerised system. The uniqueness of this system will abolish data transmissions between the two systems and will avoid checking frequently, the consistency of the data files. The inventory will be updated continuously. If data are corrected by the producer or by ANDRA if, for instance, activity of the long-lived radionuclides are re-estimated on the base of new ratio evaluation, the new system will record the new data files but will keep recording the previous ones.

CONCLUSION

ANDRA has been created to design, set-up, construct and manage long term disposal facilities for every type of radioactive waste. The main experience in France has been the management of IL and LL waste. The methods used are to be openly explained to the "man in the street" and have to take into account his demands because the public confidence in the efficiency of the management system is fundamental. It will be the key to succeed in the development of deep geological disposal for high level and long-lived radioactive waste as well as surface disposal, for very low level or specific radioactive waste.

The inventory methods of radioactive waste are improving by extending it, to toxic chemical species and to a larger number of long-lived radionuclides. A methodology for a global inventory of all type of radioactive waste is presently under investigation in ANDRA which could complement the national radioactive waste inventory, which serves to identify and locate the waste, produced in the past and to list current production.

The breakdown of the responsibilities between waste producers and ANDRA in the waste package characterization, manufacturing and quality control is operational to satisfy the stringent French safety requirements and will be globally reproduced, with eventual adaptations for the management of the other type of waste.

REFERENCES

- 1993 A. PITIOT
The French integrated waste management system
Waste Management Conference, 93, Vol 1, pp 409 – 410, Tucson.
- 1997 B. FELIX, H. ROCH, L. GAGNER, F. PINEAU
Waste acceptance criteria in relation with the safety rules of the centre de l'Aube disposal.
Low level radioactive waste technical seminar, October 8 – 10, Cordoba.

1998 J. CORCOS, M. NICOLAS

The centre de l'Aube: a five-year experience of disposal facility operation
Waste Management Conference 98, Tucson.

1999 J. CORCOS, J.L. TISON

ANDRA insuring waste conditioning quality for safe disposal. Twenty years of
relations between ANDRA and the waste producing facilities.
TOPSEAL'99, October 10 – 14, Antwerp.

Table 1

Radiological capacities of the centre de l'Aube disposal as allowed by the technical prescriptions issued in 1992, associated with the provisional license for operation and in 1999, associated with the definitive license.

Centre de l'Aube Radiological capacities in TBq	1992	1999
³ H	4. 10 ³	4. 10 ³
¹⁴ C	4. 10 ²	8.15 10 ²
³⁶ Cl	not defined	4. 10⁻¹
⁴¹ Ca	not defined	1.25 10⁻¹
⁶⁰ Co	4. 10 ⁵	4. 10 ⁵
⁵⁹ Ni	4. 10 ³	4. 10 ³
⁶³ Ni	4. 10 ⁴	4. 10 ⁴
⁷⁹ Se	not defined	3.72 10⁻²
⁹⁰ Sr	4. 10 ⁴	4. 10 ⁴
⁹³ Zr	4. 10 ²	4. 10 ²
⁹⁴ Nb	2. 10 ¹	2.01 10 ¹
⁹³ Mo	1. 10 ²	1.02
⁹⁹ Tc	1.2 10 ¹	1.23 10 ¹
¹⁰⁷ Pd	3. 10 ³	3. 10 ³
^{108m} Ag	not defined	2.49 10¹
¹²⁹ I	3.03 10 ⁻¹	3.03 10 ⁻¹
¹³⁵ Cs	6. 10 ¹	6. 10 ¹
¹³⁷ Cs	2. 10 ⁵	2. 10 ⁵
¹⁵¹ Sm	1. 10 ⁴	1. 10 ⁴
²⁴¹ Pu	2.31 10 ³	not defined
total alpha emitters	7.5 10 ²	7.5 10 ²

Figure 1 : Structures of the waste packages that correspond to the technical specifications for acceptance at the centre de l'Aube disposal and the corresponding models involved in the safety calculations. (See figure 1 on next page)

WM'00 Conference, February 27-March 2, 2000, Tucson, AZ
Safety
Corresponding structure of
calculation **the**

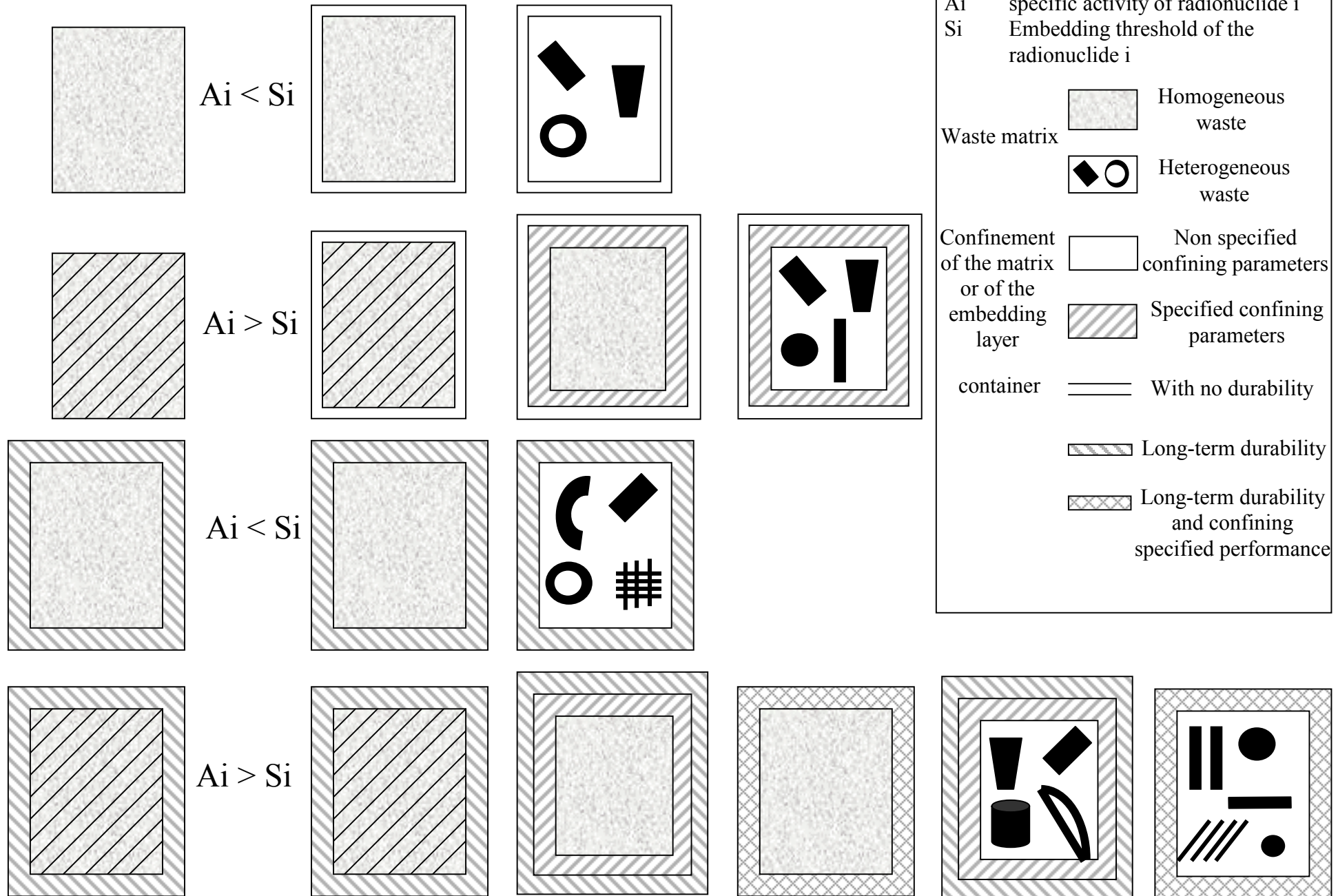

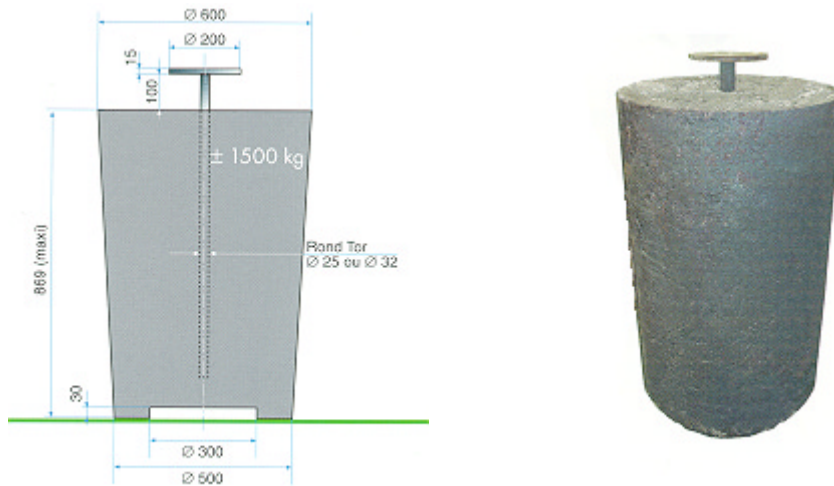

Figure 2 : Waste package manufactured by SOCODEI by melting LL radioactive scrap iron and which received an ANDRA acceptance certificate

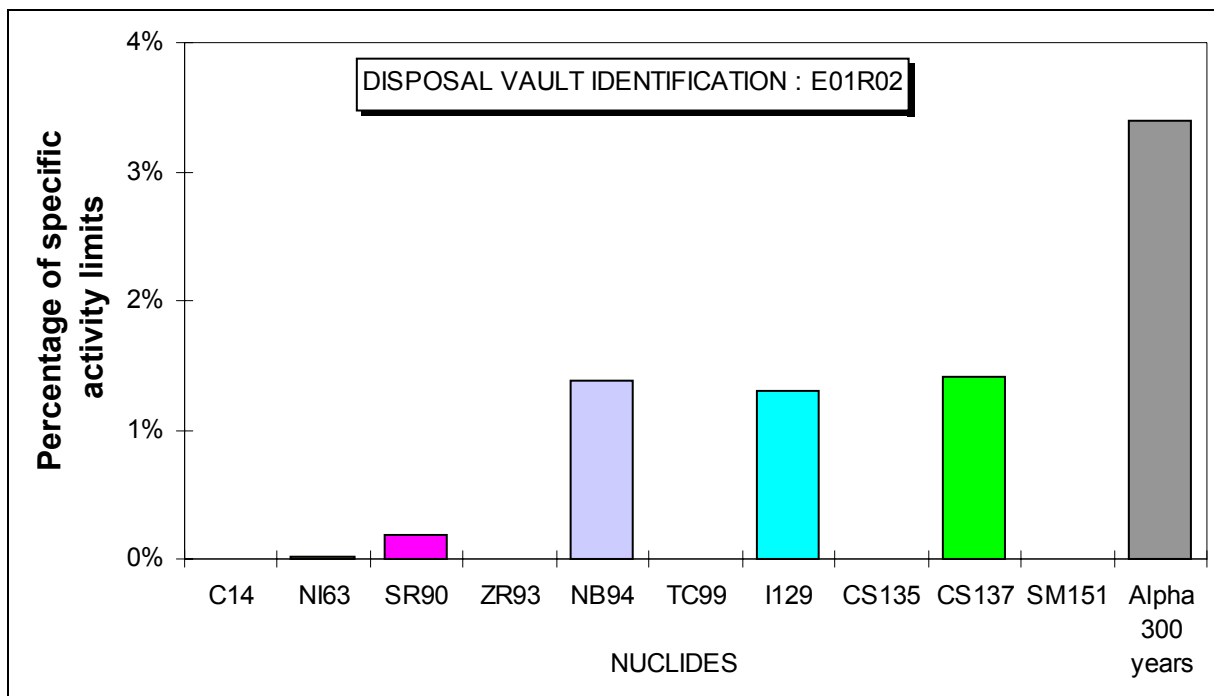

Figure 3 : Total activity of 11 radionuclides or group of radionuclides, that have been disposed in the vault E01R02. They are represented by the percentage of the specific activity limit allowed by the technical prescriptions of the centre de l'Aube disposal.

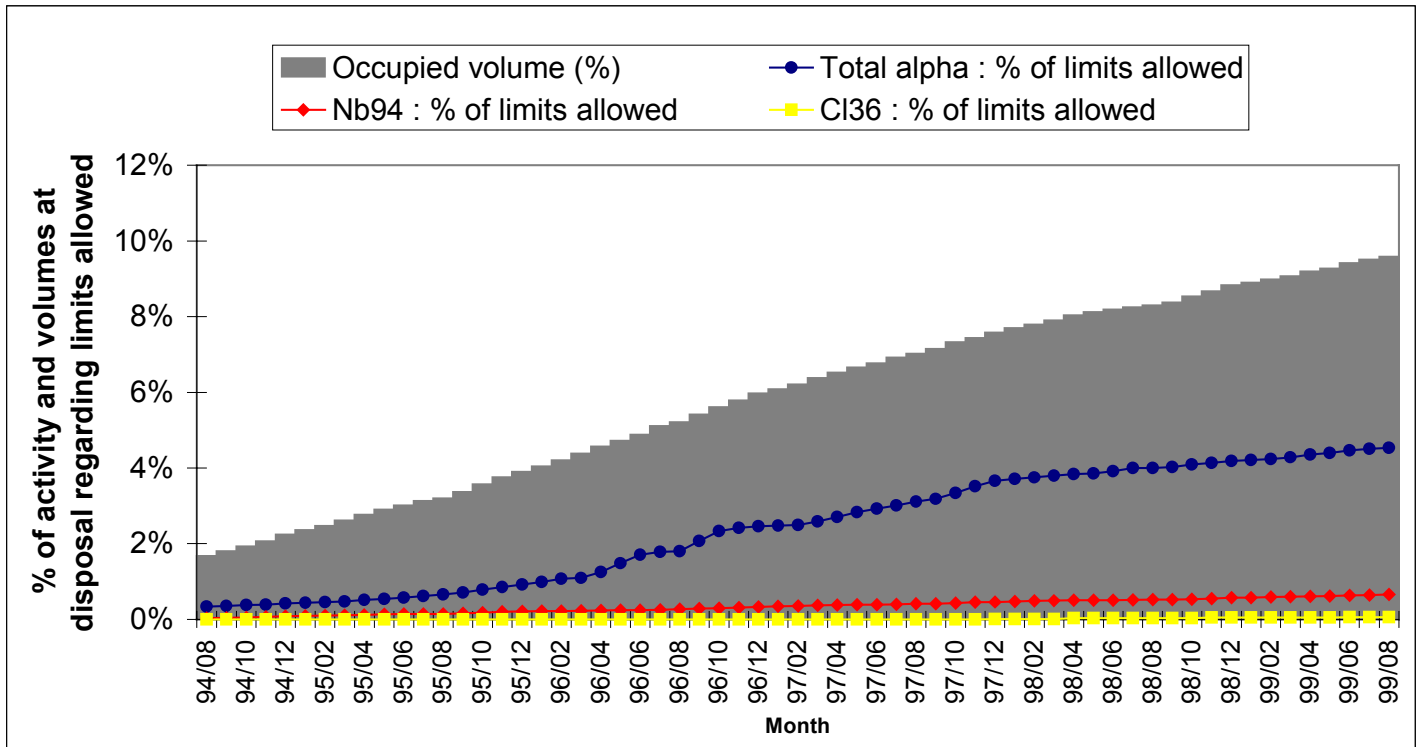

Figure 4 : Comparison, over a period of 5 years, of the volume of the total waste package disposed at the centre de l'Aube with the total activity of the alpha emitters, of ^{94}Nb and of ^{36}Cl . The total volume is represented by the percentage of the disposal capacity 1,000,000 m³. The total activity is reduced to the percentage of the corresponding radiological capacity.